

EM-1761

Shipped in packet-tape reel(5000pcs/Reel)

EM-1761 is ultra-small Hall effect ICs of a single silicon chip composed of Hall element and a signal processing IC.

Unipolar Hall Effect Switch (S-pole)	Supply Voltage 1.6~5.5V	Hall Element Pulse Excitation	High Sensitivity Bop:3mT	Output CMOS	SMT
--------------------------------------	-------------------------	-------------------------------	--------------------------	-------------	-----

●Operational Characteristics

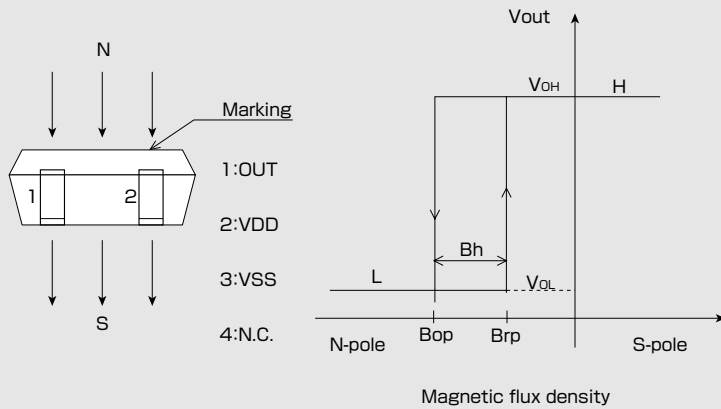

●Absolute Maximum Ratings (Ta=25°C)

Item	Symbol	Limit	Unit
Supply Voltage	VDD	-0.1 ~ 6.0	V
Output Current	I _{out}	±0.5	mA
Operating Temperature Range	Topr	-30 ~ 85	°C
Storage Temperature Range	Tstg	-40 ~ 125	°C

●Functional Block Diagram

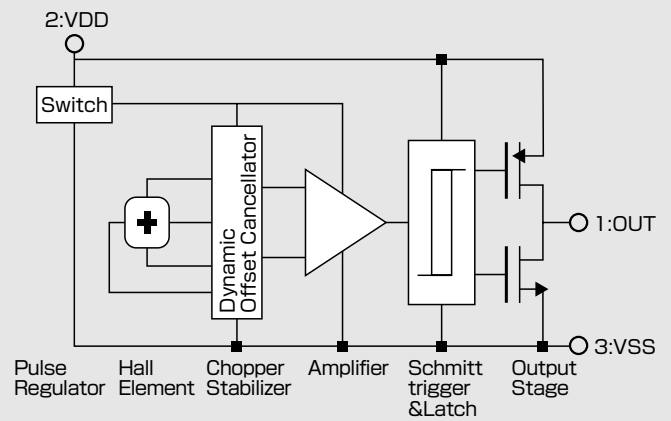

●Magnetic ① and Electrical Characteristics (Ta=25°C VDD=1.85V)

Item	Symbol	Conditions	Min.	Typ.	Max.	Unit
Supply Voltage	VDD		1.6		5.5	V
Operating Point	B _{op}		-4.0	-3.0	-1.4*	mT
Release Point	B _{rp}		-3.7*	-2.2	-1.1	mT
Hysteresis	B _h		0.3*	0.8	1.5*	mT
Period	T _p			50	100	ms
Output High Voltage	V _{oH}	I _o =-0.5mA	VDD-0.4			V
Output Low Voltage	V _{oL}	I _o =+0.5mA			0.4	V
Supply Current	I _{DD}	Average		4	9	μA

1 [mT]=10 [Gauss]

The characteristics with [*] marks are design targets.

●Magnetic Characteristics ② (Ta=-30°C~85°C VDD=1.85V)

Item	Symbol	Conditions	Min.	Typ.	Max.	Unit
Operating Point	B _{op}		-4.4	-3.0	-1.2	mT
Release Point	B _{rp}		-4.1	-2.2	-0.9	mT
Hysteresis	B _h		0.1	0.8	1.7	mT

Note) The above specifications are design targets.

●Application Circuit

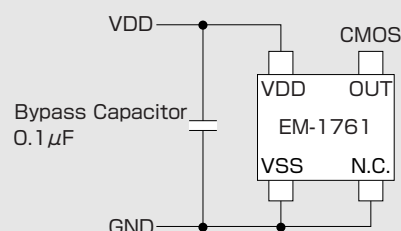

•Please be aware that our products are not intended for use in life support equipment, devices, or systems. Use of our products in such applications requires the advance written approval of our sales staff.
 Certain applications using semiconductor devices may involve potential risks of personal injury, property damage, or loss of life. In order to minimize these risks, adequate design and operating safeguards should be provided by the customer to minimize inherent or procedural hazards. Inclusion of our products in such applications is understood to be fully at the risk of the customer using our devices or systems.

●Package (Unit:mm)

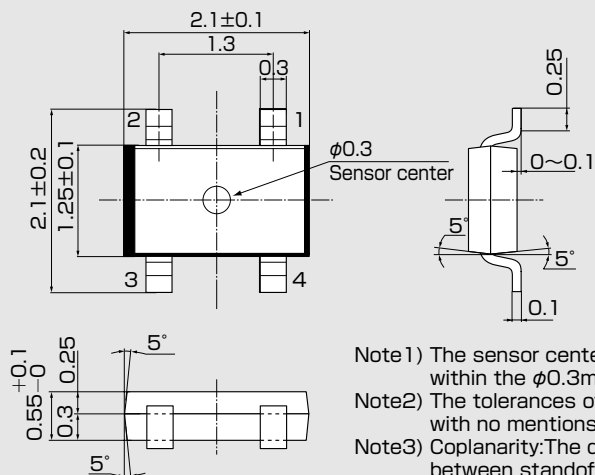

- Note1) The sensor center is located within the $\phi 0.3$ mm circle.
- Note2) The tolerances of dimensions with no mentions is ± 0.1 mm.
- Note3) Coplanarity: The differences between standoff of terminals are max.0.1mm.
- Note4) The sensor part is located 0.4mm(typ.) far from marking surface.

Pin No.	Connection	Function	Comment
1	OUT	Output Voltage	
2	VDD	Supply Voltage	
3	VSS	GND	
4	N.C.	-	Short to GND

●(For reference only)Land Pattern (Unit:mm)

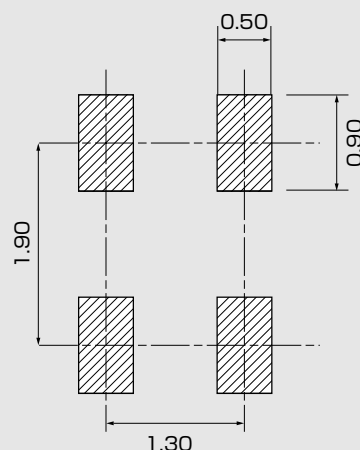

●Supply Voltage

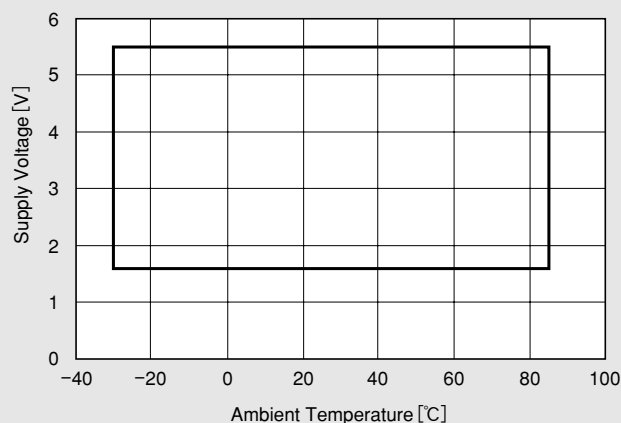

●IDD Pulse Driving (VDD=1.85V)

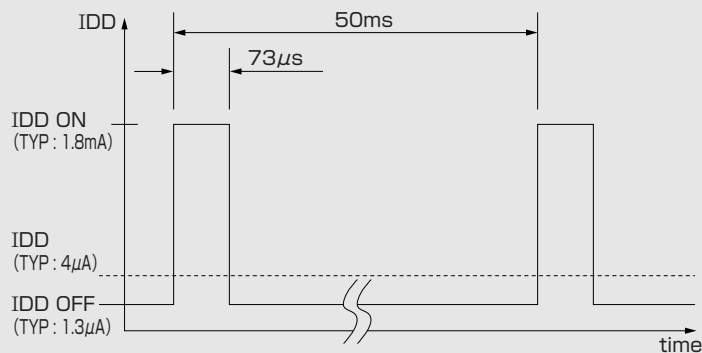

●Temperature Dependence of Bop, Brp

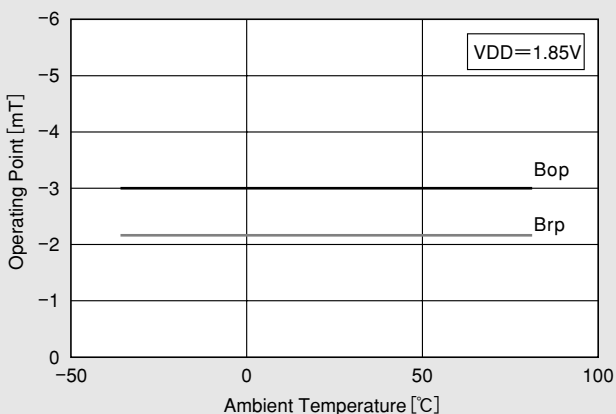

●Function Timing Chart

