

# HW-102A

Shipped in packet-tape reel (6000pcs/Reel) or bulk (500pcs per pack)

Notice : It is requested to read and accept "IMPORTANT NOTICE" written on the back of the front cover of this catalogue.

## ●Absolute Maximum Ratings

Item	Symbol		Limit	Unit
Max. Input Current	$I_C$	Const. Current Drive	20	mA
Operating Temp. Range	Topr.		-40 ~ +110	°C
Storage Temp. Range	Tstg.		-40 ~ +125	°C

Note : For constant-voltage drive, stay within this input voltage derating curve envelope.

## ●Electrical Characteristics( $T_a=25^\circ\text{C}$ )

Item	Symbol	Conditions	Min.	Typ.	Max.	Unit
Output Hall Voltage	$V_H^*$	Const. Voltage Drive B=50mT, $V_C=1\text{V}$	196		370	mV
Input Resistance	$R_{in}$	B=0mT, $I_C=0.1\text{mA}$	250		450	$\Omega$
Output Resistance	$R_{out}$	B=0mT, $I_C=0.1\text{mA}$	250		450	$\Omega$
Offset Voltage	$V_{os}(Vu)$	B=0mT, $V_C=1\text{V}$	-7		+7	mV
Temp. Coefficient of $V_H$	$\alpha V_H^*$	Average on 0~40°C B=50mT, $I_C=5\text{mA}$		-1.8		%/°C
Temp. Coefficient of $R_{in}$	$\alpha R_{in}^*$	Average on 0~40°C B=0mT, $I_C=0.1\text{mA}$		-1.8		%/°C
Dielectric Strength		100V D.C	1.0			M $\Omega$

Notes : 1.  $V_H = V_{HM} - V_{os}(Vu)$  (VHM:meter indication)

$$2. \alpha V_H = \frac{1}{V_H(T_1)} \times \frac{V_H(T_3) - V_H(T_2)}{(T_3 - T_2)} \times 100$$

$$3. \alpha R_{in} = \frac{1}{R_{in}(T_1)} \times \frac{R_{in}(T_3) - R_{in}(T_2)}{(T_3 - T_2)} \times 100$$

$$T_1 = 20^\circ\text{C}, T_2 = 0^\circ\text{C}, T_3 = 40^\circ\text{C}$$

## ●Dimensional Drawing(Unit : mm)

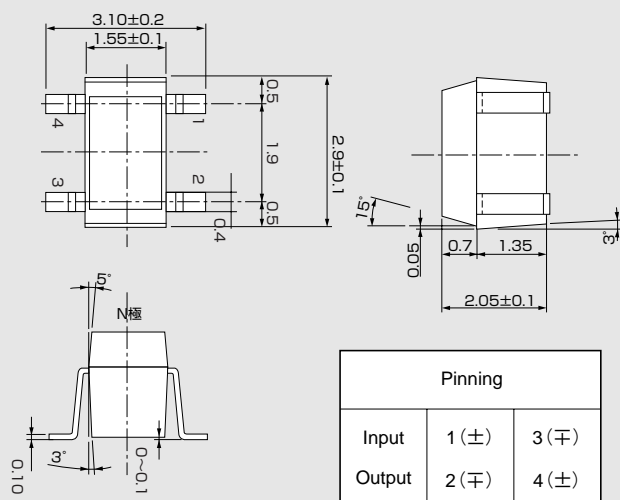

## ●Classification of Output Hall Voltage ( $V_H$ )

Rank	$V_H$ [mV]	Conditions
D	196 ~ 236	B=50mT, $V_C=1\text{V}$ Constant Voltage Drive
E	228 ~ 274	
F	266 ~ 320	
G	310 ~ 370	

Note : When ordering, specify 3-rank or wider range(e.g.,C,D,E).

## ●Input Current Derating Curve

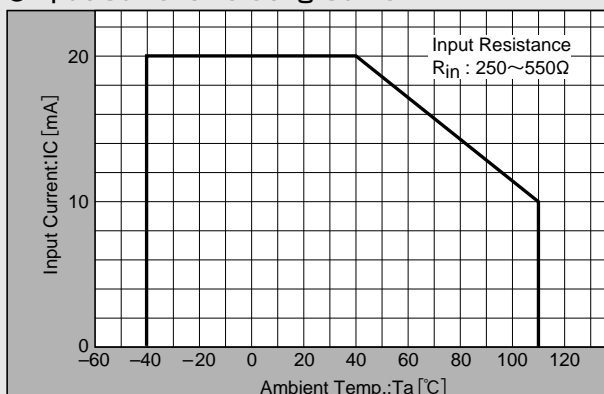

Note :  $R_{in}$  of Hall element decreases rapidly as ambient temperature increases. Ensure compliance with input current derating curve envelope, throughout the operating temperature range.

## ●Input Voltage Derating Curve

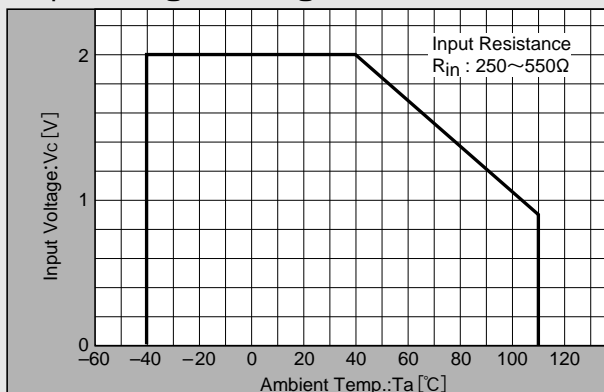

Note : For constant-voltage drive, stay within this input voltage derating curve envelope.

•Please be aware that our products are not intended for use in life support equipment, devices, or systems. Use of our products in such applications requires the advance written approval of our sales staff.  
 Certain applications using semiconductor devices may involve potential risks of personal injury, property damage, or loss of life. In order to minimize these risks, adequate design and operating safeguards should be provided by the customer to minimize inherent or procedural hazards. Inclusion of our products in such applications is understood to be fully at the risk of the customer using our devices or systems.

●Characteristic Curves

$R_{in}-T$

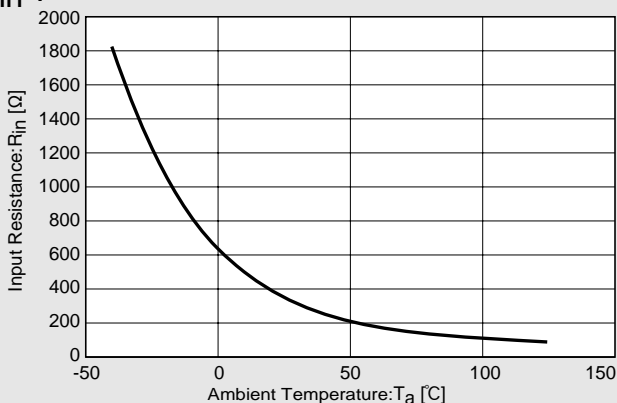

$V_H-B$

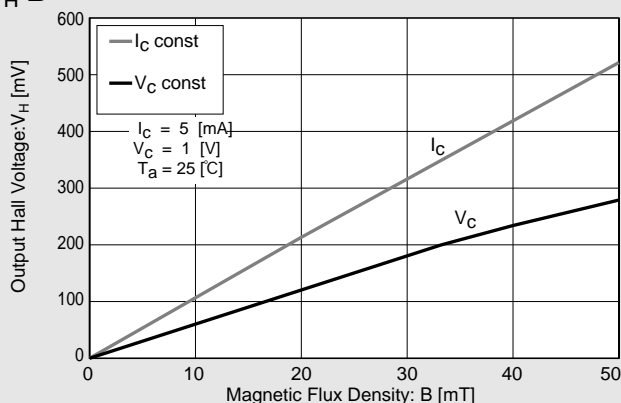

$V_H-T$

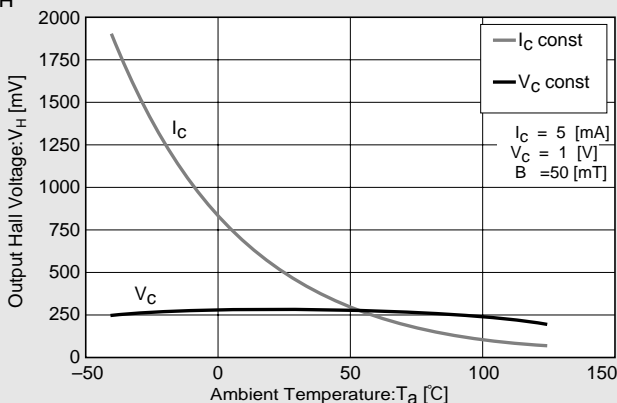

$V_H-V_C, V_H-I_C$

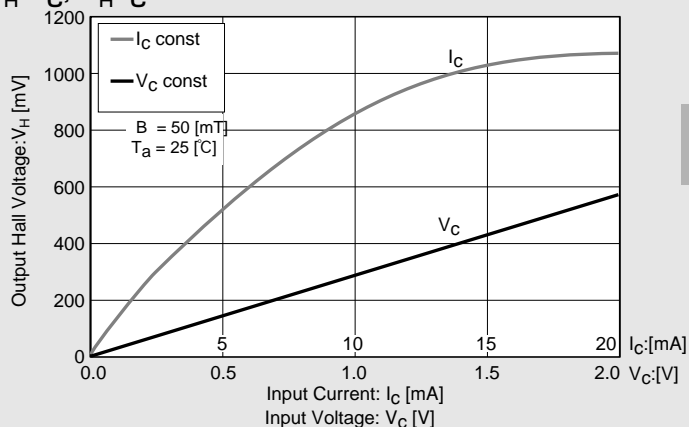

$V_{OS}(V_u)-T$  (For reference only)

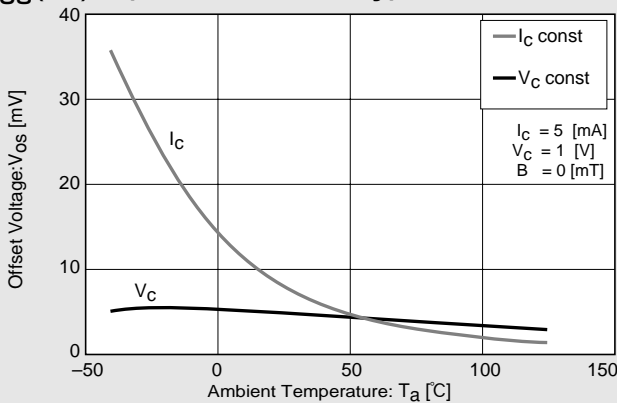

$V_{OS}(V_u)-V_C, V_{OS}-I_C$  (For reference only)

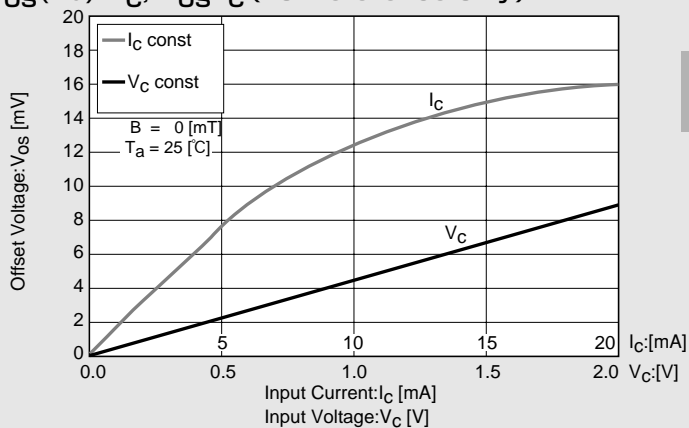

※Magnetic Flux Density  
 1[mT]=10[G]

In This Example :  $R_{in}=350$  [ $\Omega$ ] ,  $V_{OS}=4.7$  [mV] ,  $[V_C=1$  [V]]