

**DESCRIPTION:**

Hall Probe D for F3A Magnetic Transducers is a single-chip fully integrated 3-axis Hall-Probe with a transparent window over the Hall elements.

The Hall Probe D for F3A Magnetic Transducers contains a CMOS integrated circuit, which incorporates three groups of mutually orthogonal Hall elements, biasing circuits, amplifiers, and a temperature sensor. The integrated Hall elements occupy very small area (150µm x 150µm), which provides very high spatial resolution of the probe. The CMOS IC technology enables very high precision in the fabrication of the vertical and horizontal Hall elements, which gives high angular accuracy (orthogonality error < 0.1°) of the three measurement axis of the probe. The on-chip application of the spinning-current technique in the biasing of the Hall elements suppresses the planar Hall effect. The on-chip signal pre-processing enables a very high frequency bandwidth (DC to 25 kHz) of the probe; and on-chip signal amplification provides high output signals of the Hall probe.

The sensor chip is embedded in the probe package and connected to the CaH cable, which makes this probe both mechanically and electrically very robust. The chip is glued onto a reference ceramic plate suitable for an appropriate fixing of the probe. The mechanical package includes a transparent window (diam. 1.5 mm) over the Hall elements integrated on the Hall probe IC die.

The output of the Hall Probe are high-level analog voltages proportional with each of the measured components of a magnetic flux density and a voltage proportional with the probe temperature.

**KEY FEATURES:**

- **The mechanical probe package includes a transparent window (diam. 1.5 mm) over the Hall elements integrated on the Hall probe IC die**
- **Fully integrated CMOS 3-axis (Bx, By, Bz) Hall Probe, of which one, two, or three channels are used**
- **Very high spatial resolution (By: 0.03 x 0.005 x 0.03mm<sup>3</sup>; Bx and Bz: 0.15 x 0.01 x 0.15 mm<sup>3</sup>)**
- **High angular accuracy (orthogonality error less than 0.1°)**
- **High frequency bandwidth (from DC up to 25kHz)**
- **Virtually no planar Hall Effect**
- **Negligible inductive loops on the Probe**
- **Integrated temperature sensor on the probe for temperature compensation**
- **The Hall Probe D for F3A Magnetic Transducers is consisting part (Module H) of the F3A Magnetic Field Transducer, Digital Teslameter and Magnetic Field Mapper**
- **Suitable for as 3-axis (03, XYZ), 2-axis (XY, XZ, YZ) and as 1-axis (0X, 0Y, 0Z) Hall Probe**
- **Available as a separate unit for OEM customers**

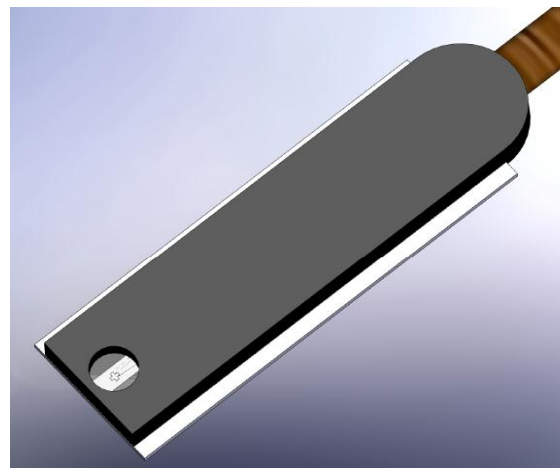

**PROBE DIMENSIONS AND CHARACTERISTICS:**

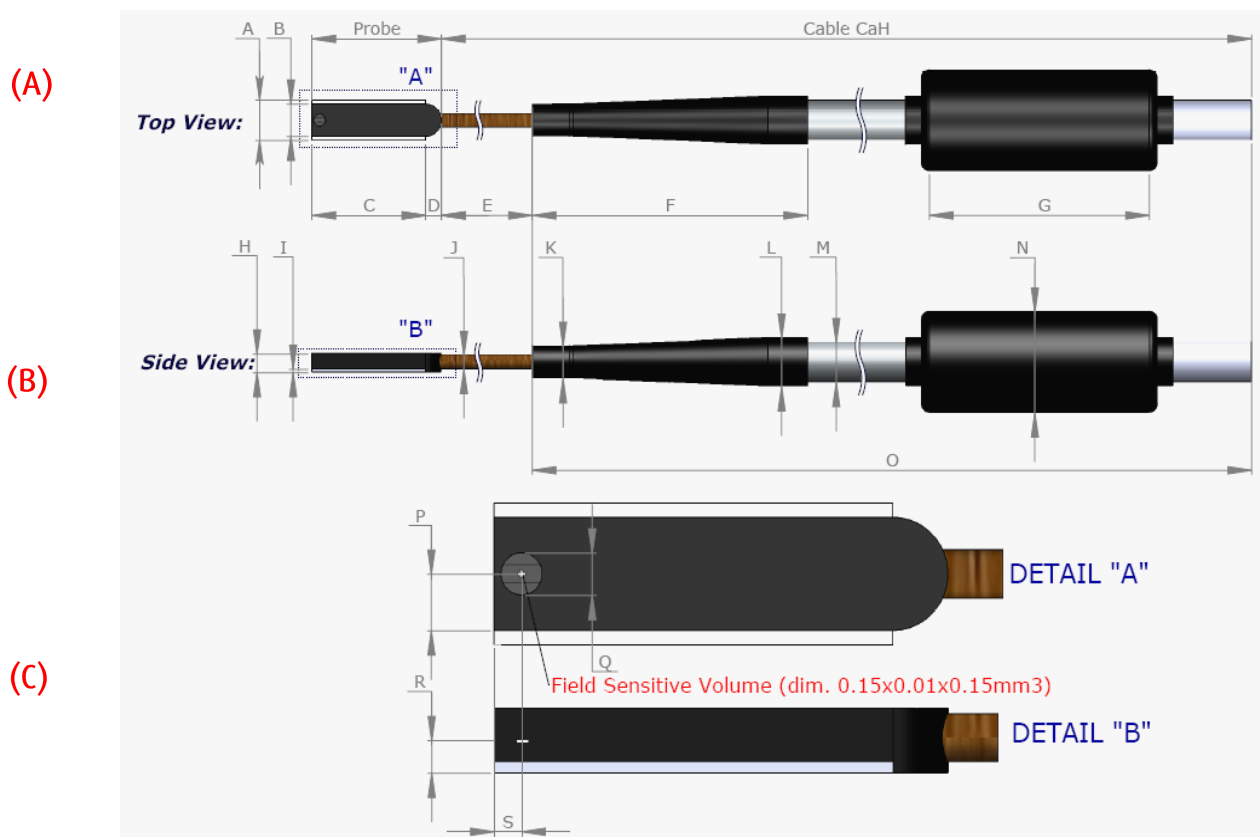

Figure 1. Dimensions of D Hall probe and cable: (A) Top view; (B) Side view; (C) Isometric view with reference Cartesian coordinate system of the probe head. Magnetic Field Sensitive Point (MFSP) is marked with a transparent window.

**Probe & Cable Dimensions & Tolerances [mm]**

A	5.0	F	35 ± 3	K	∅ 3.8 ± 0.2	P	2.0 ± 0.1
B	4.0 ± 0.1	G	30 ± 1	L	∅ 6.0 ± 0.2	Q	∅ 1.5 ± 0.2
C	14.5 ± 0.1	H	2.3 ± 0.1	M	∅ 4.9 ± 0.1	R	1.3 ± 0.1
D	2.0 ± 0.1	I	0.4	N	∅ 16 ± 1	S	1.0 ± 0.1
E	1500 ± 25	J	1.7 ± 0.2	O	X ± 1%(X) <sup>1)</sup>		

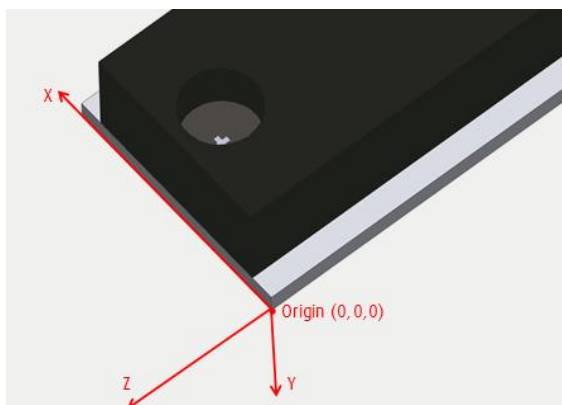

Figure 2. The reference Cartesian coordinate system of D Hall probe

Dimension	X [mm]	Y [mm]	Z [mm]
Magnetic Field sensitive volume (MFSV):	0.15	0.01	0.15
Position of the center of MFSV: (corresponding to MFSP, see Fig.1)	2.5 ± 0.1	-1.3 ± 0.1	-1.0 ± 0.1
Total Probe external dimensions:	5.0 (ref. ceramics)	2.3 ± 0.1	16.5 ± 0.2
	4.0 ± 0.1 (Probe head)		
Angular accuracy of the axes:	± 0.5° with respect to the reference surface		
CaH Cable:	Shielded, with a flexible thin part near the probe and ferrite sleeve on the thicker part (see Fig. 1)		
<sup>1)</sup> Total length of the CaH cable:	<ul style="list-style-type: none"> <li>▪ Standard: <b>2 m</b> (example of Probe notation: <b>03D02</b>)</li> <li>▪ Optional: <b>XX m</b> (example of Probe notation: <b>03Dxx</b>)</li> </ul> <i>Different cable lengths are available upon request.</i>		

## INSTALLATION MANUAL FOR D HALL PROBE

Although the D probe is very robust with respect to its size, it should be handled with special care. Considering that we deal with a high-precision device of very small dimensions, following precautions should help to avoid damage to the probe during installation and handling, and ensure that the device's accurate calibration remains preserved.

The mounting of the probe should be carried out by application of very low pressure to its head and thin wires. If the probe head is clamped, the user needs to make sure that the environment surface in contact with the reference plane of the probe is flat and covers as much of the probe reference surface as possible (see Fig. 4). Do not apply more force than required to hold the probe in its mounting.

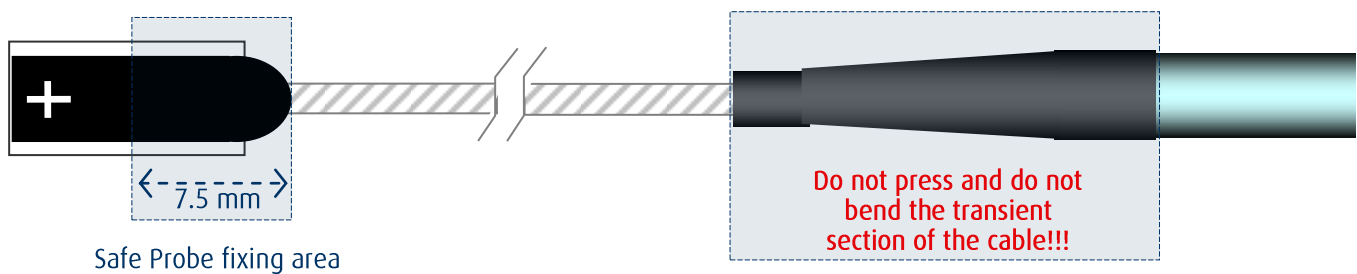

Figure 3. **Safe fixing area of the D Probe head**

In order to prevent rupture of the thin wires from the probe head, the user should fix and secure the probe cable in the proximity of the head. The thin wires of the flexible section of the probe need to be folded with care; repeated strong bending should be avoided.

Also, avoid any high pressure and bending of the transient section between the thin and the thick cables.