

GMW Associates

Electromagnet Fringe Field Plot

Date: 8/3/2018 Page: 1 of 4
Engr: Y.Qin

Model: 5403 Power Supply: Kepco 20V/20A x2 Set Current: 0A
PS Serial No:

Field Meter 1: Bartington Mag-03MC/1000 sn:2700, read from NI DAQ

Field Meter 2: MetroLAB THM1176HF (in-house unit)

Note 1: Pole face=38mm, gap=24.3mm

Note 2: X=Y=Z=0mm is the center of the magnet gap

Note 3: X is horizontal along pole gap, +X towards current cable/water connection side.

Note 4: Z is along pole axis

Note 5: Y is vertical up

Note 5: Measured at 0A. Power supply is off

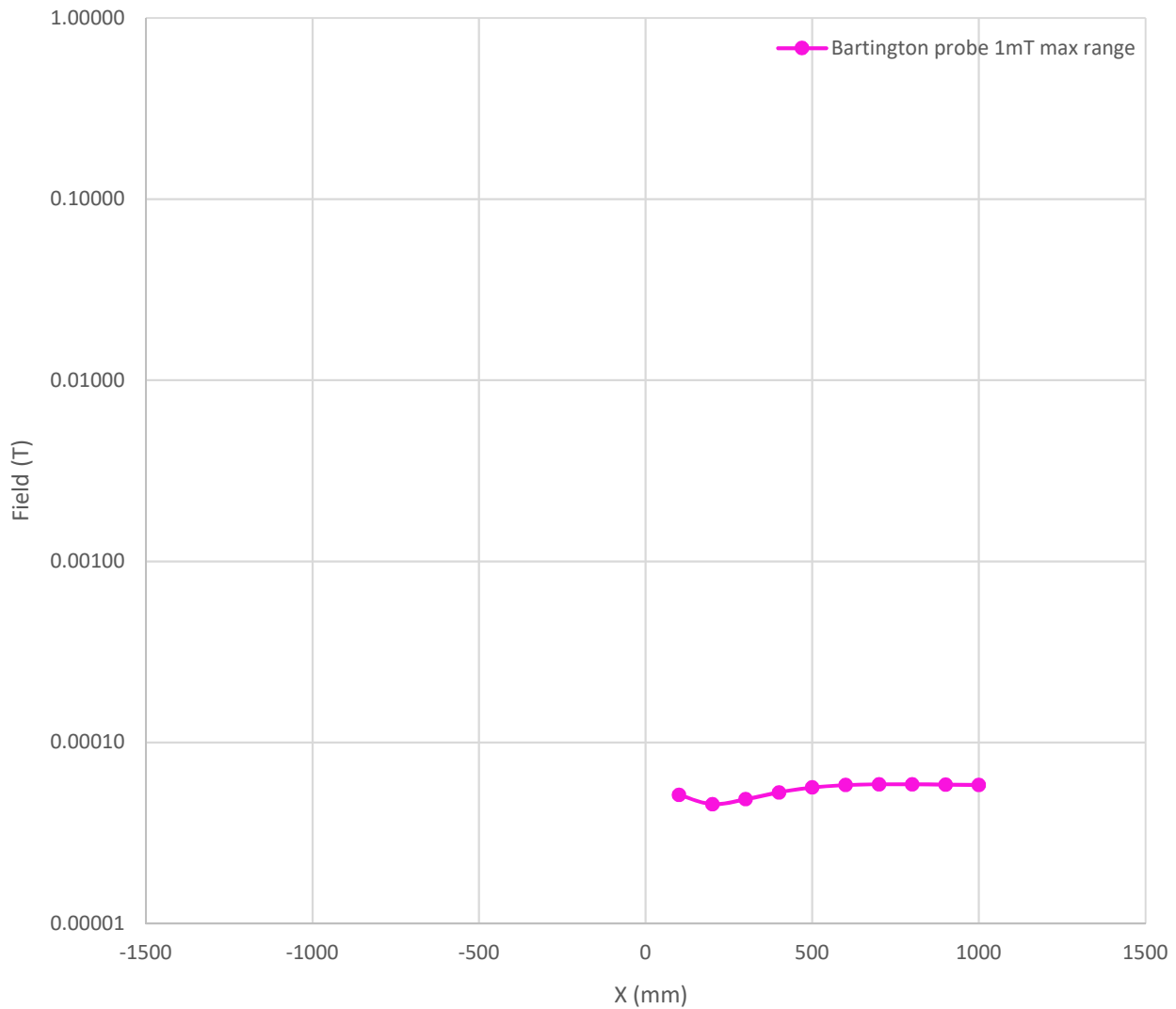

GMW Associates

Electromagnet Fringe Field Plot

Date: 8/3/2018 Page: 2 of 4
Engr: Y.Qin

Model: 5403 Power Supply: Kepco 20V/20A x2 Set Current: 40A
PS Serial No:

Field Meter 1: Bartington Mag-03MC/1000 sn:2700, read from NI DAQ

Field Meter 2: MetroLAB THM1176HF (in-house unit)

Note 1: Pole face=38mm, gap=24.3mm

Note 2: X=Y=Z=0mm is the center of the magnet gap

Note 3: X is horizontal along pole gap, +X towards current cable/water connection side.

Note 4: Z is along pole axis

Note 5: Y is vertical up

Note 5: Measured at 40A

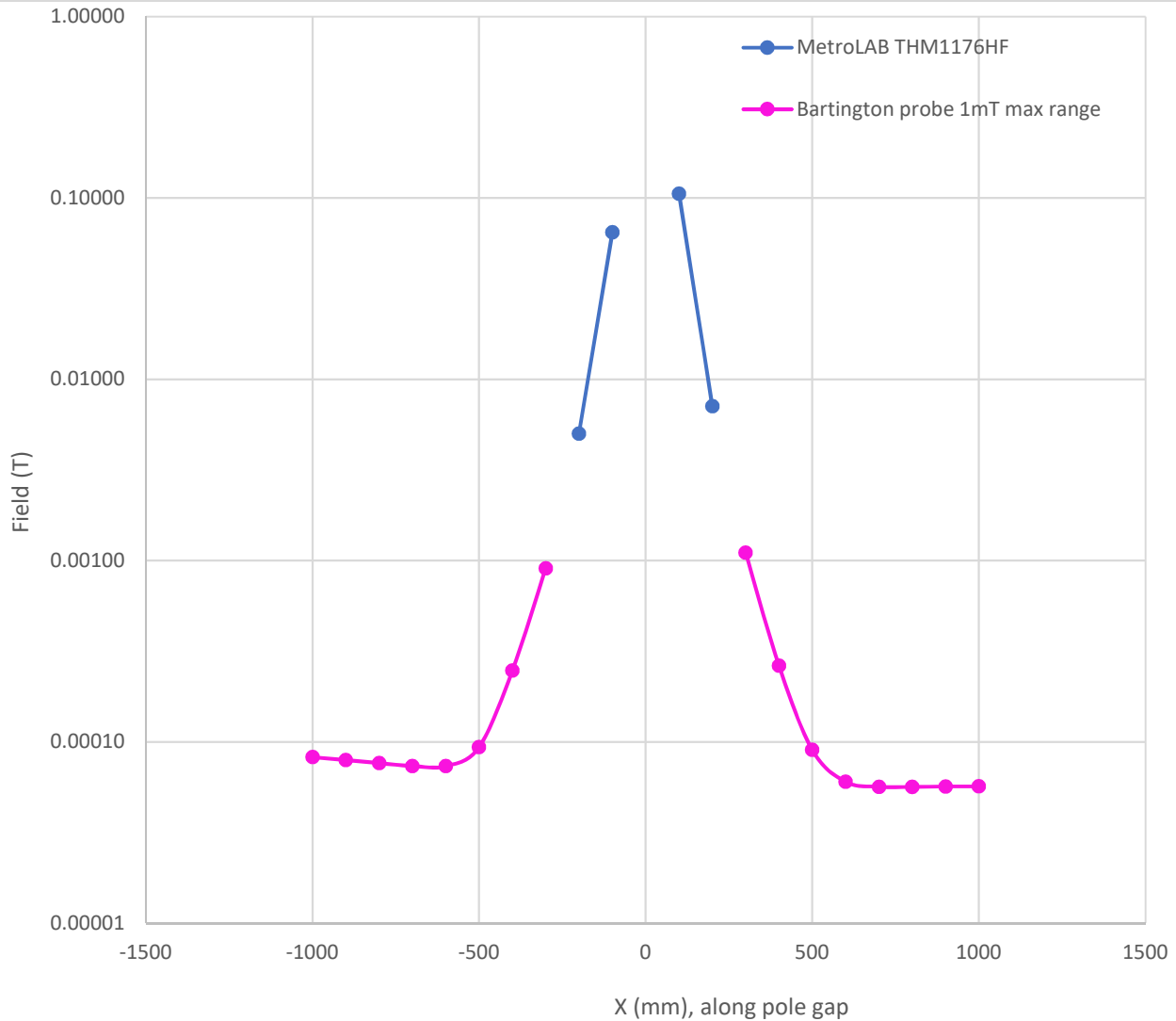

GMW Associates

Electromagnet Fringe Field Plot

Date: 8/3/2018 Page: 3 of 4
Engr: Y.Qin

Model: 5403 Power Supply: Kepco 20V/20A x2 Set Current: 40A
PS Serial No:

Field Meter 1: Bartington Mag-03MC/1000 sn:2700, read from NI DAQ

Field Meter 2: MetroLAB THM1176HF (in-house unit)

Note 1: Pole face=38mm, gap=24.3mm

Note 2: X=Y=Z=0mm is the center of the magnet gap

Note 3: X is horizontal along pole gap, +X towards current cable/water connection side.

Note 4: Z is along pole axis

Note 5: Y is vertical up

Note 5: Measured at 40A

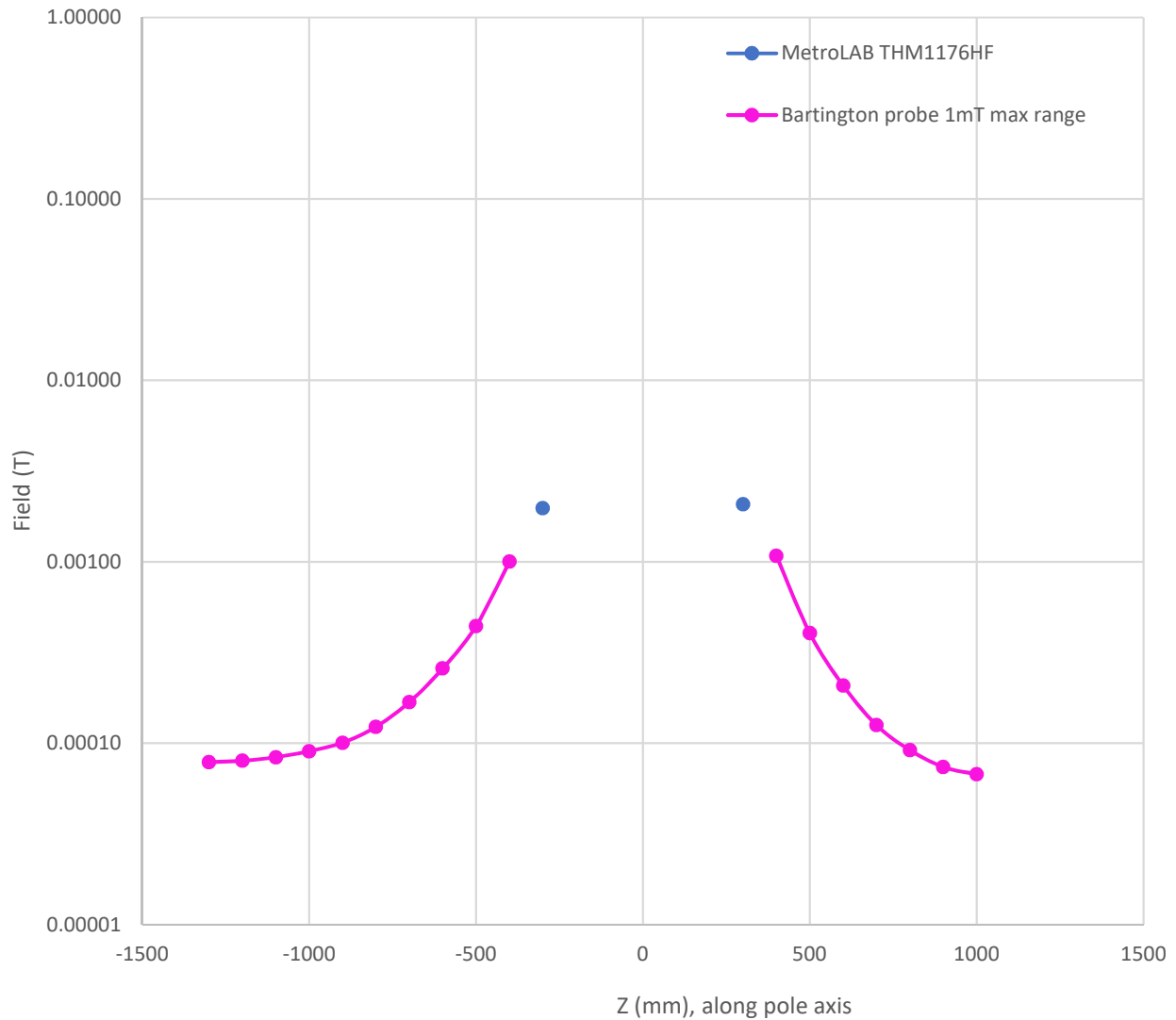

GMW Associates

Electromagnet Fringe Field Plot

Date: 8/3/2018 Page: 4 of 4
Engr: Y.Qin

Model: 5403 Power Supply: Kepco 20V/20A x2 Set Current: 40A
PS Serial No:

Field Meter 1: Bartington Mag-03MC/1000 sn:2700, read from NI DAQ

Field Meter 2: MetroLAB THM1176HF (in-house unit)

Note 1: Pole face=38mm, gap=24.3mm

Note 2: X=Y=Z=0mm is the center of the magnet gap

Note 3: X is horizontal along pole gap, +X towards current cable/water connection side.

Note 4: Z is along pole axis

Note 5: Y is vertical up

Note 5: Measured at 40A

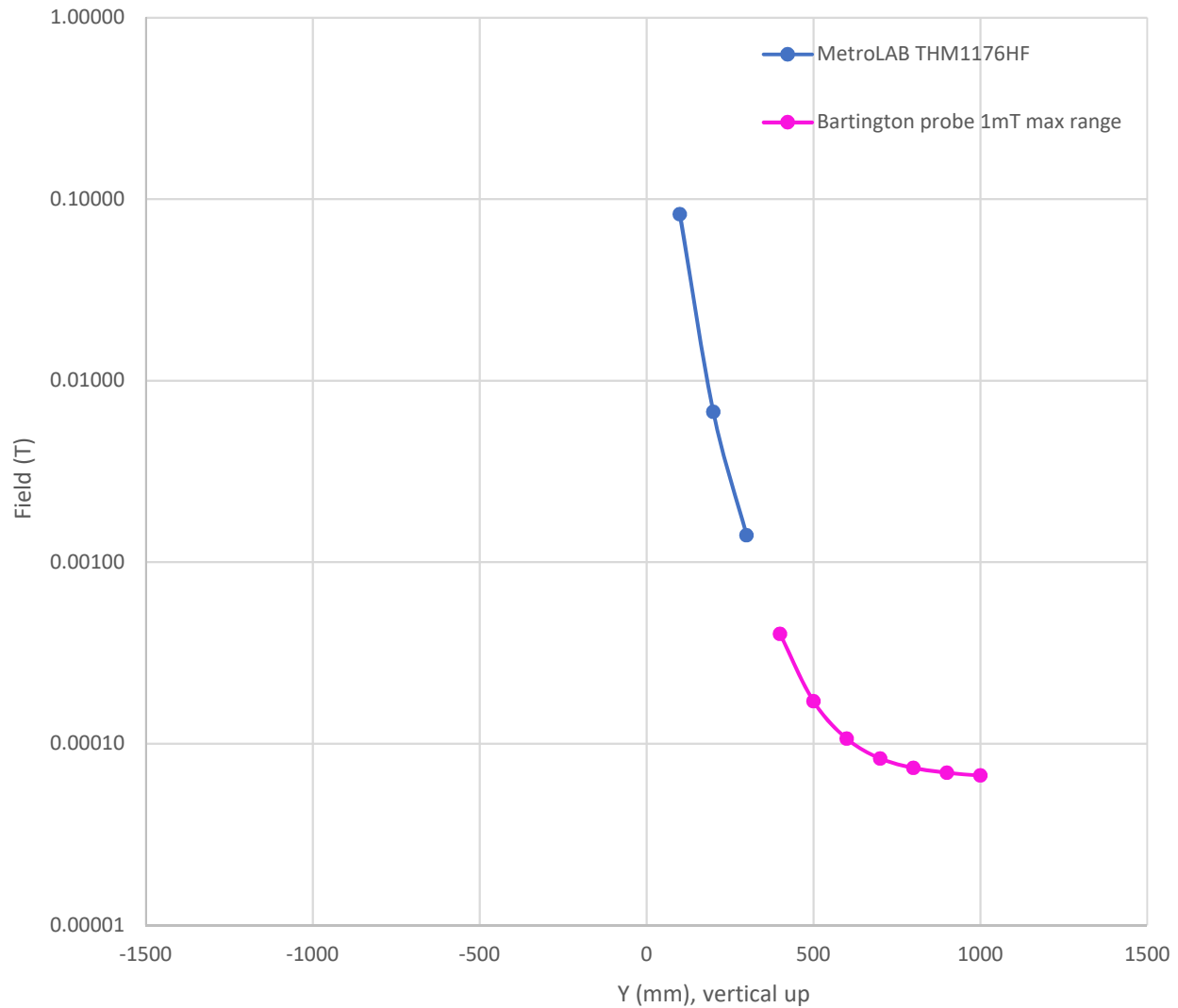

FRONT VIEW

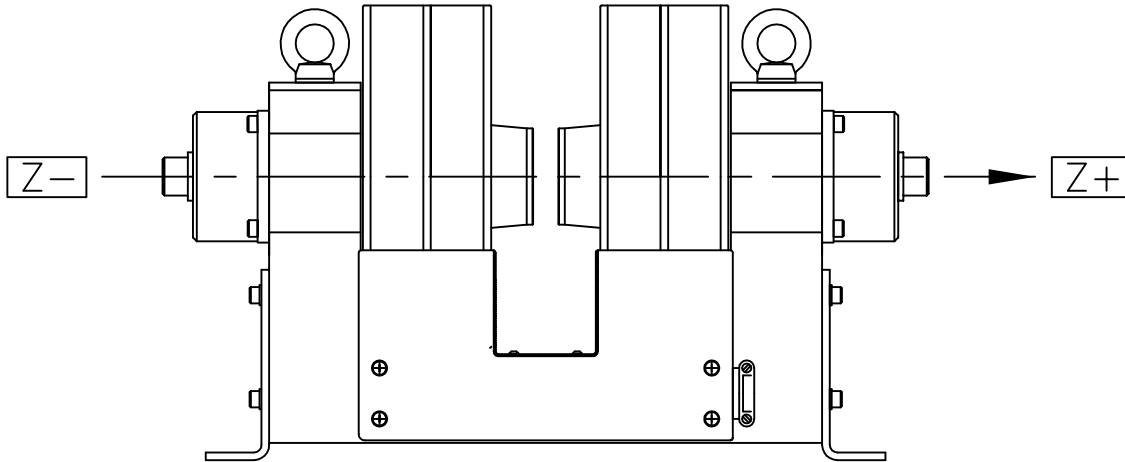

SIDE VIEW

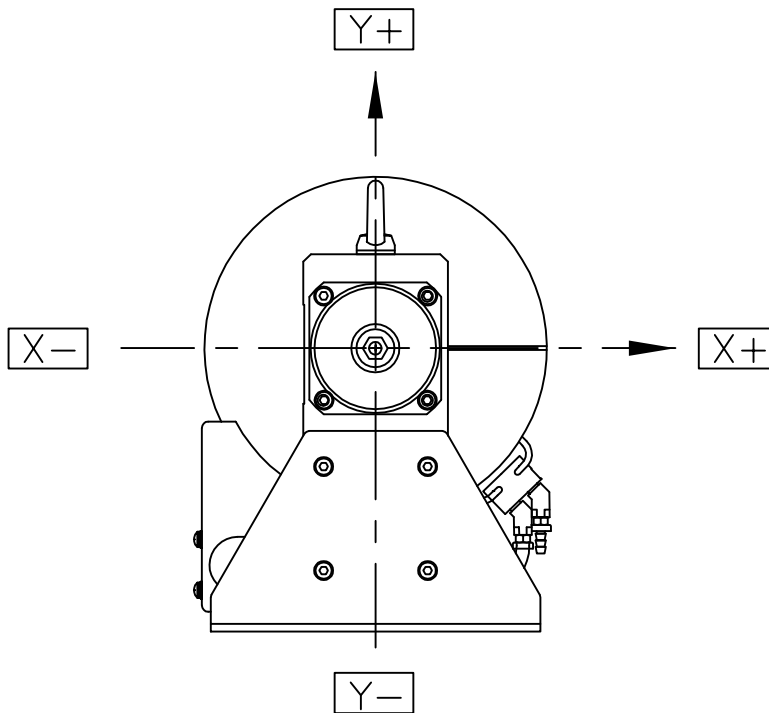

PROPRIETARY

This document contains information proprietary to GMW Inc. It must not be reproduced or disclosed to others or used in any other way, in whole or part, except as authorized in writing by GMW Inc.

MAGNETIC PLOTTING AXES

18900740

A

SHEET 1 OF 1