



156 rue du Mont Rond
Espace Allondon Ouest
01630 Saint Genis Pouilly, France

Tel: +33 450 42 66 42
Fax: +33 450 42 66 43
Email: info@bergoz.com

Integrating Current Transformer

User's Manual

Rev. 4.2

Record of updates

Version	Date	Updates performed
4.0	01/2018	Review of the full manual. Obsoletes all previous versions
4.1	12/2019	Modification of the cover page and creation of the distributors' page
4.2	04/2021	Addition of the CAW_50 option and the BK200C option Update of the drawing in the "Installation over a vacuum chamber" chapter

DISTRIBUTORS

U.S.A.

GMW Associates

GMW Associates
www.gmw.com
sales@gmw.com

Japan

HR HAYASHI-REPIC

Hayashi-Repic Co., Ltd.
www.h-repic.co.jp
sales@h-repic.co.jp

India

GEEBEE
INTERNATIONAL

GEEBEE International
www.geebeginternational.com
info@geebeginternational.com

China

CONVe-YI 北京科维泰信

Beijing Conveyi Limited
www.conveyi.com
sales@conveyi.com

REPRESENTATIVE AGENT

South Korea

**SEYOUNG**

Seyoung Co., Ltd
www.seyoungsys.com
apark@seyoungsys.com

TABLE OF CONTENTS

INITIAL INSPECTION	2
WARRANTY	2
ASSISTANCE	2
SERVICE PROCEDURE	2
RETURN PROCEDURE	3
SAFETY INSTRUCTIONS	3
GENERAL DESCRIPTION	4
In-flange models	5
In-air models	6
BCM-IHR-E	6
OPERATING PRINCIPLE	7
ELECTRICAL CONNECTIONS	7
Coaxial connectors on the ICT sensor	7
OUTPUT SIGNAL POLARITY	8
CABLE CONNECTION	8
MECHANICAL DIMENSIONS AND DRAWINGS	8
In-flange models	8
In-air models	9
Drawings	9
INSTALLATION	9
In-flange models	9
In-air models	10
Common mode filters	10
INSTALLATION OVER A VACUUM CHAMBER	10
Wall current break or "gap"	11
Thermal protection of the In-air ICT	11
Keeping high harmonics of the beam out of the In-air ICT cavity	11
ICT RADIATION RESISTANCE	13
Organic and radiation-sensitive materials used in the "Standard" sensor:	13
Organic and radiation-sensitive materials used in the "Rad-Hard" sensor:	13

INITIAL INSPECTION

It is recommended that the shipment be inspected immediately upon delivery. If it is damaged in any way, contact Bergoz Instrumentation or your local distributor. The content of the shipment should be compared to the items listed on the invoice. Any discrepancy should be notified to Bergoz Instrumentation or its local distributor immediately. Unless promptly notified, Bergoz Instrumentation will not be responsible for such discrepancies.

WARRANTY

Bergoz Instrumentation warrants its beam current monitors to operate within specifications under normal use for a period of 12 months from the date of shipment. Spares, repairs and replacement parts are warranted for 90 days. Products not manufactured by Bergoz Instrumentation are covered solely by the warranty of the original manufacturer. In exercising this warranty, Bergoz Instrumentation will repair, or at its option, replace any product returned to Bergoz Instrumentation or its local distributor within the warranty period, provided that the warrantor's examination discloses that the product is defective due to workmanship or materials and that the defect has not been caused by misuse, neglect, accident or abnormal conditions or operations. Damages caused by ionizing radiations are specifically excluded from the warranty. Bergoz Instrumentation and its local distributors shall not be responsible for any consequential, incidental or special damages.

ASSISTANCE

Assistance in installation, use or calibration of Bergoz Instrumentation beam current monitors is available from Bergoz Instrumentation, 01630 Saint Genis Pouilly, France. It is recommended to send a detailed description of the problem by email to info@bergoz.com.

SERVICE PROCEDURE

Products requiring maintenance should be returned to Bergoz Instrumentation or its local distributor. Bergoz Instrumentation will repair or replace any product under warranty at no charge. The purchaser is only responsible for transportation charges.

For products in need of repair after the warranty period, the customer must provide a purchase order before repairs can be initiated. Bergoz Instrumentation can issue fixed price quotations for most repairs. However, depending on the damage, it may be necessary to return the equipment to Bergoz Instrumentation to assess the cost of repair.

RETURN PROCEDURE

All products returned for repair should include a detailed description of the defect or failure, name and fax number of the user. Contact Bergoz Instrumentation or your local distributor to determine where to return the product. Returns must be notified by fax prior to shipment.

Return should be made prepaid. Bergoz Instrumentation will not accept freight-collect shipment. Shipment should be made via UPS, FedEx or DHL. Within Europe, the transportation service offered by the Post Offices "EMS" (Chronopost, Datapost, etc.) can be used. The delivery charges or customs clearance charges arising from the use of other carriers will be charged to the customer.

SAFETY INSTRUCTIONS

The instrument designated as "Integrating Current Transformer" may become RADIOACTIVE when exposed to ionizing radiations.

Standard models contain:

- Cobalt Up to 0.4 Kg
- Iron..... Up to 0.2 Kg

GENERAL DESCRIPTION

ICT Integrating Current Transformer is a passive transformer designed to measure the charge of very short pulses with high accuracy.

The ICT is capable of integrating pulses with a rise time down to femtoseconds with no significant loss.

The ICT magnetic cores and associated windings are essentially noise free. The measurement noise and consequently the measurement resolution are determined by the signal processing.

The ICT output signal is disturbed by coherent EMP noise, e.g., powerful laser, kicker magnet, etc. In such cases, it may be difficult to measure pulse charge below 200pC. Read further for advice how to mitigate EMP noise. Signal integration like boxcar integrators or Bergoz Instrumentation BCM-IHR may allow more precise measurements.

The Integrating Current Transformer is a capacitively shorted transformer and a fast read out transformer in a common magnetic circuit.

The magnetic cores are made from thin ribbons of Cobalt / Molybdenum amorphous alloy interleaved with Nickel / Iron crystalline alloy.

The ICT integrates the signal with a time constant of 1 to 20 nanoseconds, depending on the model.

As a result, rise and fall are both slowed down, the eddy current losses become negligible and the instrument is a very linear integrator for the very high frequency spectrum typical of sub-nanosecond pulses. The ICT output frequency spectrum is decreased by orders of magnitude in comparison to the pulse frequency spectrum.

Very precise calibration is possible. The ICT's only drawback is that the original shape of the signal is lost. The ICT delivers its output in a 50 Ω load.

Linearity and beam position sensitivity were tested first in 1987 on the electron/positron collider CESR at Cornell University¹. A measure of linearity showed an error $< 3e-4$ for a 20% bunch length variation (56 ps to 70 ps). A measure of beam position dependency showed an error $< 1e-4$ for ± 10 mm of beam axis change (off-center).

The temperature dependence is negligible.

ICT is available in two packaging styles: In-flange models or In-air models

¹ Design and preliminary tests of a beam monitor for LEP, K.B. Unser, CERN, proceedings of the 1989 IEEE Particle Accelerator Conference, Vol. 1 page 71.

In-flange models

In-flange models are current transformers whose core(s) are embedded in a pair of flanges. Flanges can be Conflat, ISO, KF, Dependex, EVAC or specials with usual inner diameters. In-flange ICT are UHV compatible. Down to 1e-9 mbar, soap or alcohol cleaning before installation is however recommended; to reach pressure down to 1e-11 mbar, adequate pumping and prior cleaning, (e.g., plasma) are required.

100°C (212°F) should never be exceeded at any time during bake out or operation unless it is made from a selection of higher temperature alloys and materials:

- Option BK150C allows bake out at 150°C (300°F)
- Option BK185C allows bake out at 185°C (365°F)
- Option BK200C allows bake out at 200°C (392°F)

In-flange ICT wall current break (“gap”) is a ceramic ring (Al2O3 99.7%) brazed onto two Kovar transition sleeves.

Standard models are made from AISI 304 steel, AISI 316LN is available on option.

In-flange models have the below syntax:

In-flange ICT	
-CFx”-	x” is the CF flanges OD [inch]
-xx.x-	xx.x is the sensor ID [mm]
-xx-	xx is the sensor axial length [mm]
-UHV-	UHV: Sensor UHV compatible with brazed ceramic wall current break; <ul style="list-style-type: none"> - As delivered down to 1e-9 mbar - After adequate cleaning down to 1e-11 mbar
-xxx-	Output pulse full length duration, standard is -070- [ns]
-xx.x	xx.x is the sensitivity of the sensor [V/A]
Example: ICT-CF6”-60.4-40-UHV-070-5.0	
Options for In-flange ICT	
-ARBxx-	In-flange ICT sensor with special arbitrary aperture
-316LN-	In-flange ICT sensor in AISI316LN instead of 304
-BK150C-	In-flange ICT sensor bakeable at 150°C (300°F)
-BK185C-	In-flange ICT sensor bakeable at 185°C (365°F)
-BK200C-	In-flange ICT sensor bakeable at 200°C (392°F)
-LD-	Low Droop sensor option
-H	Radiation-tolerant sensor option, all components R.I.>6
-CAW1_50	1-turn calibration winding, loaded 50Ω (0.25W), insulated and SMA connector

In-air models

In-air models are current transformers whose core(s) are potted in a copper toroidal casing. In-air ICT are typically installed over a vacuum chamber whose wall current flow is interrupted by a user-supplied break (“gap”) protected from stress by bellows. The wall current is diverted by a user-supplied wall current bypass. A user-supplied shield prevents the RF leaking out of the gap from radiating over.

In-air ICT should not be heated above 100°C (212°F) at any time.
 In-air ICT should not be placed in vacuum, they might burst open.
 Specially degassed In-air ICT can be placed in mild vacuum (1e-4 mbar).

In-air models have the below syntax:

In-air ICT	
-xxx-	xxx is the sensor ID [mm]
-xxx-	Output pulse full length duration, standard is -070- [ns]
-xx.x	xx.x is the sensitivity of the sensor [V/A]
Example: ICT-055-070-5.0	
Options for In-air ICT	
-VAC-	In-air ICT sensor degassed. Warning: excessive degassing <1e-4 mbar
-LD-	Low Droop sensor option
-H	Radiation-tolerant sensor option, all components R.I.>6
-CAW1_50	1-turn calibration winding, loaded 50Ω (0.25W), insulated and SMA connector

BCM-IHR-E

You may have received BCM-IHR-E electronics with the ICT. The ICT & BCM-IHR-E system includes:

Description	Order code
1	Integrating Current Transformer e.g. ICT-CF4”1/2-34.9-40-UHV-5.0
2	BCM-IHR-E electronics module BCM-IHR-E
3	19” RF-shielded chassis for BCM-E modules of all versions with power supply and spare power supply BCM-RFC/XX XX: number of wired BCM stations
4	ICT to BCM-RFC chassis interconnect coaxial cable BCM-C/xxx or BCM-RHC/xxx xxx: cable length in meters

Please refer to the BCM-IHR-E manual for more information.

OPERATING PRINCIPLE

The Integrating Current Transformer (ICT) is a passive transformer designed to measure the charge in a very fast pulse with high accuracy. It is capable of integrating a pulse of length <1 fs with no significant loss.

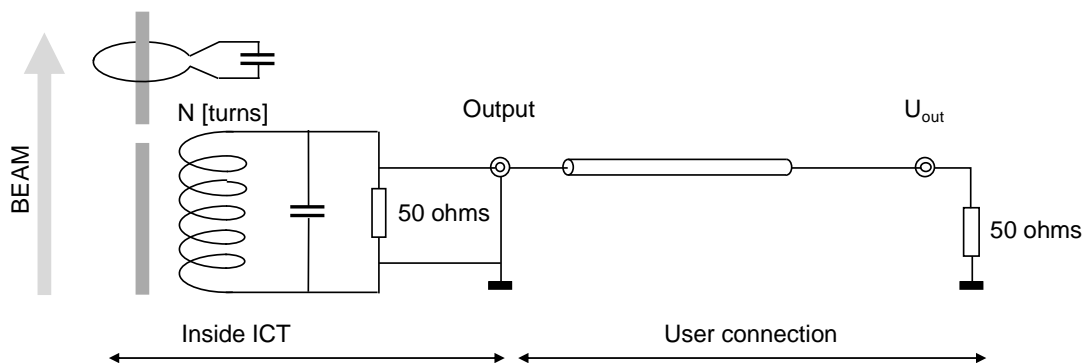

The ICT is a capacitively shorted transformer coupled to a fast readout transformer in a common magnetic circuit².

It delivers a pulse with ca. 20 ns rise time irrespective of the beam pulse rise time. The ICT output pulse charge is in exact proportion to the beam pulse charge.

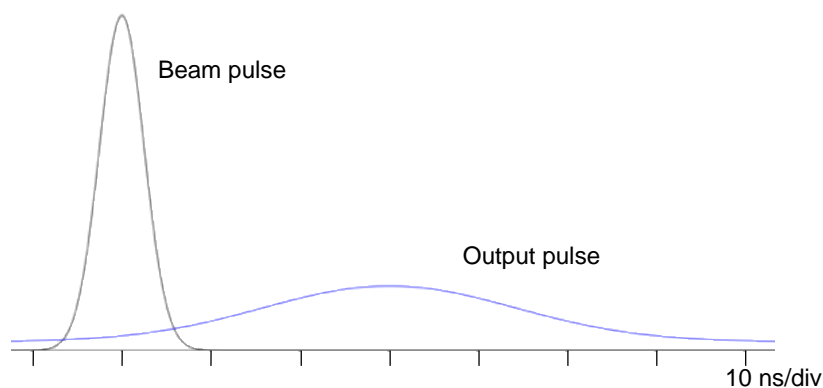

ELECTRICAL CONNECTIONS

Coaxial connectors on the ICT sensor

In-flange and In-air ICT are equipped with SMA jack with PTFE dielectric.

ICTs ordered with radiation tolerant option -H are equipped with SMA jack with PEEK dielectric.

BNC or N-type connectors are available on request.

² Measuring Bunch Intensity, Beam Loss and Bunch Lifetime in LEP, K.B.Unser, Proceedings of the 2nd European Particle Accelerator Conference, 1990, Vol.1, p.786

OUTPUT SIGNAL POLARITY

The Integrating Current Transformer is bipolar. Arrows are printed on the outer surface of the toroid. Charges (positive) crossing the aperture in the direction of the arrow give positive outputs. E.g. an electron beam passing in the direction of the arrow yields a negative output.

CABLE CONNECTION

Most 50Ω coaxial cable types are appropriate to connect the ICT to its measuring instrument. To measure charge below 500 pC, depending on the background noise, consider using double-shielded cable.

When the ICT signal is integrated, its integration is not affected by the cable attenuation. It is only affected by the ohmic resistance of the cable's center conductor.

MECHANICAL DIMENSIONS AND DRAWINGS

In-flange models

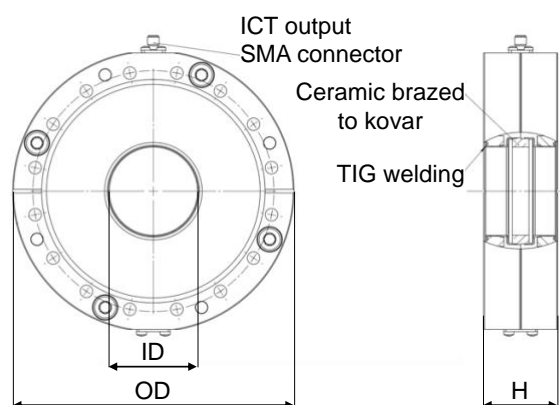

In-flange ICT sensor order code	Flange OD (inch)	Pipe OD (inch)	Mating flange	ID (mm)	H (mm)
ICT-CF3"3/8-22.2-40-UHV-070-xx	3.375"	1"	DN/NW50CF	22.2	
ICT-CF4"1/2-34.9-40-UHV-070-xx	4.5"	1.5"	DN/NW63CF	34.9	
ICT-CF4"1/2-38.0-40-UHV-070-xx	4.5"	40 mm	DN/NW63CF	38.0	
ICT-CF6"-47.7-40-UHV-070-xx	6"	2"	DN/NW100CF	47.7	
ICT-CF6"-60.4-40-UHV-070-xx	6"	2.5"	DN/NW100CF	60.4	
ICT-CF6"3/4-96.0-40-UHV-070-xx	6.75"	4"	DN/NW130CF	96.0	
or ICT-CF8"-96.0-40-UHV-070-xx	8"		DN160/NW150CF	96.0	
ICT-CF10"-147.6-40-UHV-070-xx	10"	6"	DN/NW200CF	147.6	
ICT-CF12"-198.4-40-UHV-070-xx	12"	8"	DN/NW250CF	198.4	
ICT-CFXX"-XXX-XX-UHV-070-all sensitivities					40.0

In-air models

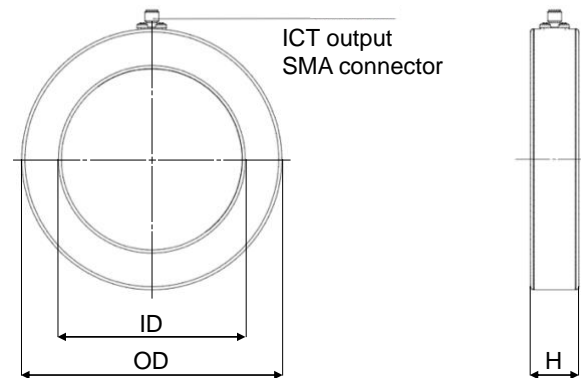

In-air ICT sensor order code	ID min (mm)	OD max (mm)	H max (mm)
ICT-016-070-xx	16	42	
ICT-028-070-xx	28	64	
ICT-055-070-xx	55	91	
ICT-082-070-xx	82	118	
ICT-122-070-xx	122	156	
ICT-178-070-xx	178	226	
ICT-XXX-070-2.5 Vs/C and lower sensitivity			32
ICT-XXX-070-5.0 Vs/C			45
ICT-XXX-070-10.0 Vs/C			58

Drawings

Drawings in .pdf can be found on our website:
www.bergoz.com :: ICT & BCM-IHR :: Downloads :: Technical drawings
 Dimensions missing on the website can be obtained asking info@bergoz.com

INSTALLATION

In-flange models

In-flange model's mechanical parts are in direct electrical contact with the vacuum chamber. Its output connector body, hence, the cable shield is also in direct electrical contact. It is therefore of paramount importance to equip every section of the coaxial cable with common mode filters to mitigate ground loops. A cable section is any length of cable which connector bodies are grounded at both ends, e.g., through a grounded patch panel.

In-flange ICT bolts must be tightened at the recommended torque according to the flange type, but not beyond.

In-air models

In-air ICT must be installed over the vacuum chamber, not too far away from the wall current gap. It is recommended to install bellows to avoid stress on the gap, wall current bypass and RF overall shield to prevent RF leaking outside.

The output connector body is in direct electrical contact with the In-air ICT copper shell. Therefore, to prevent ground loops, it is recommended that the In-air ICT shell is electrically isolated from the vacuum chamber.

Common mode filters

Common mode filters must be installed at both ends of each cable segments. Each filter must comprise one MnZn ferrite tube, core or bead, and one iron-based nanocrystalline core, e.g., Hitachi Metals' Finemet alloy FT-3KL.

INSTALLATION OVER A VACUUM CHAMBER

The installation of an In-air ICT on the outside of a vacuum chamber requires some precautions.

- a) The electrical conductivity of the vacuum chamber must be interrupted in the vicinity of the ICT, otherwise the wall current will flow thru the ICT aperture and cancel the beam current.
- b) The wall current higher frequencies must be diverted around the ICT thru a low impedance path.
- c) A fully-enclosing shield must be installed over the ICT and vacuum chamber electrical break to avoid RF interference emission.
- d) The enclosing shield forms a cavity. Cavity ringing at any of the beam harmonics must be avoided.
- e) The ICT must be protected from being heated beyond 100°C (212°F) during vacuum chamber bake-out.
- f) The higher harmonics of the beam should be prevented from escaping the vacuum chamber, because (1) they are not "seen" by the ICT therefore unnecessary, (2) they heat the ICT and any other conductive material inside the cavity, (3) they cause various ringing modes in the cavity.

Note: The ICT does not need to be protected from external magnetic fields. When it is exposed to external magnetic fields it may saturate; this causes the droop to increase up to a factor of 2. It has no effect on the ICT linearity.

Wall current break or “gap”

When installing an In-air ICT over a vacuum chamber, a break or “gap” must be installed in order to stop the wall current.

If vacuum pressure is $1e-7$ mbar or above, a polymer gasket O-ring can be used between two flanges to assure the desired galvanic isolation.

For vacuum pressures below $1e-7$ mbar, a ceramic ring brazed to the vacuum chamber is indicated.

Thermal protection of the In-air ICT

The ICT must not be heated beyond 100°C (212°F). If the vacuum chamber requires bake out, a thermal shield must be installed between the vacuum chamber (or the heating sleeves) and the ICT.

The thermal shield can be a simple copper cylinder cooled by water circulating in a copper tube brazed onto the cylinder.

The water circuit must not pass thru the ICT aperture. It must enter and go out on the same side of the ICT, otherwise it makes a shorting loop around the ICT toroid.

Keeping high harmonics of the beam out of the In-air ICT cavity

The transformer, the gap capacitance and the wall current bypass form together a cavity. It is important to prevent unnecessary harmonics from entering the cavity:

The beam current flows thru the vacuum chamber.

The wall current follows the conductive vacuum chamber walls.

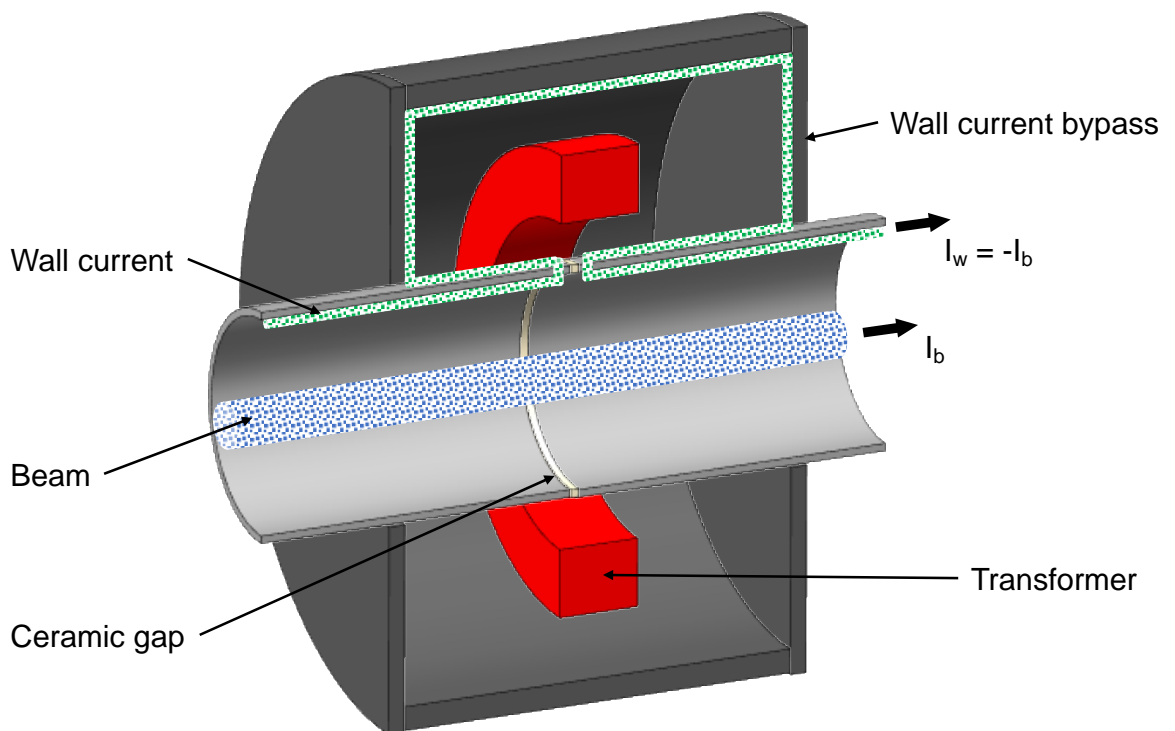

The transformer “sees” the wall current I_w . The higher frequencies of the wall current frequency spectrum will pass thru the capacitance of the ceramic gap, while the lower frequencies will enter the cavity and induce a flux in the transformer core.

Note that the full charge of the wall current pulse passes thru the cavity, irrespective of the value of the gap capacitance.

ICT RADIATION RESISTANCE

ICTs contain materials which may be damaged by ionizing radiations. They are listed hereafter:

Organic and radiation-sensitive materials used in the "Standard" sensor³:

The "Standard" sensor is supplied when the "Rad-Tolerant" option is not ordered.

Component	Material	Radiation resistance
Wiring insulation	Polyester 1350 tape	10 ⁶ Gy
	Fiber glass	> 10 ⁸ Gy
	with rubber adhesive	> 10 ⁶ Gy
Stress absorbent	Silicon rubber tape SIR	5 x 10 ⁵ Gy
	Silicon rubber SIR	2 x 10 ⁵ Gy
Connector dielectric	PTFE "Teflon"	< 10 ³ Gy

Organic and radiation-sensitive materials used in the "Rad-Hard" sensor³:

The "Rad-Tolerant" sensor is supplied when the "Rad-Tolerant" option is ordered. The ordering code and model number are then terminated by -H.

Component	Material	Radiation resistance
Wiring insulation	Polyester 1350 tape	10 ⁶ Gy
	Fiber glass	> 10 ⁸ Gy
	with rubber adhesive	> 10 ⁶ Gy
Stress absorbent	Polyurethane foam PU	5 x 10 ⁶ Gy
	Polyurethane rubber PUR	5 x 10 ⁶ Gy
Connector dielectric	Poly-ether-ether-ketone PEEK	6 x 10 ⁷ Gy

The above radiation resistance values are indicative only. They do not imply any guarantee of whatever nature from the manufacturer.

The manufacturer specifically declines any responsibility for any damage, direct or consequential, caused by ionizing radiations.

³ Source: Compilation of Radiation Damage Test Data, H.Schönbacher et al.,
CERN 79-04: <http://cds.cern.ch/record/133188/files/CERN-HS-RP-038-YR-PARTI.pdf?version=1>
CERN 79-08: <http://cds.cern.ch/record/141784/files/CERN-HS-RP-093.pdf?version=1>
CERN 82-10: <http://cds.cern.ch/record/141784/files/CERN-HS-RP-093.pdf?version=1>
CERN 89-12: <http://cds.cern.ch/record/205520/files/CERN-89-12.pdf?version=1>

ACKNOWLEDGEMENT

ICT was developed at CERN during the 80's by Dipl. Ing. Klaus B. Unser.

Saint Genis Pouilly

Last revised: April 2021