

USER MANUAL

# BB-BPM

## Baseband Beam Position Monitor

Rev. 5.0



[www.bergoz.com](http://www.bergoz.com)

**bergoz**<sup>™</sup>  
INSTRUMENTATION

More than 40 years of experience recognized in the world of particle accelerators

## Record of updates

Version	Date	Updates performed
2.1	09/2007	CONNECTORS PINS ALLOCATION Rev.3.1: SUM, Sum of logs, is on pin 7 of front panel DB9 connector
2.2	10/2007	CONNECTORS PINS ALLOCATION Rev.3.2: BB-BPM-ABCD optional coaxial outputs are changed: LOGA is in b22 (used to be in b31) LOGB is in b25 (used to be in b28) LOGC is in b28 (used to be in b25) LOGD is in b31 (used to be in b22). Analog ground on c20 is suppressed. Analog ground on chassis rear panel DB15 pin 3 is suppressed. Beam Trigger output positive-going is now on: Pins c19 and c20; pin c20 used to be a ground pin. Chassis rear panel DB15 pins 2 and 3. Pin 3 used to be a ground. Beam-based Center Enable is now on pins a13 and b13; it used to be on pin a13 only. Correction of manual: Chassis rear panel DB15 pin 14 is not a ground pin.
2.3	11/2007	CONNECTORS PINS ALLOCATION Rev.3.3 Power supply pin changes: Those pins are no longer grounds:DB9 pin 7; DIN41612M pin c18 and Rear chassis DB15 pin 12.
3.0	08/2014	Units formerly designated "BB-BPM" are now designated BB-BPM-E New BB-BPM-E based on PCB 111.1.2 first customer shipment +15V DC injection in the A, B, C and D RF inputs, conditional to +15V on-board jumper Warning on +15V damage risks in manual.
3.0.1	08/2014	BB-PBM-FEFA based on PCB 206.1 first customer shipment
3.0.2	08/2014	BB-BPM-FEFA Addendum to BB-BPM User's Manual
4.0	01/2020	Review of the full manual. Obsoletes all previous versions
4.1	11/2020	Correction of chapter "Algorithm, Sensitivity & Polarity"
5.0	07/2024	Manual layout update

## DISTRIBUTORS

### U.S.A.

**GMW Associates**

GMW Associates  
[www.gmw.com](http://www.gmw.com)  
[sales@gmw.com](mailto:sales@gmw.com)

### Japan

**HR HAYASHI-REPIC**

Hayashi-Repic Co., Ltd.  
[www.h-repic.co.jp](http://www.h-repic.co.jp)  
[sales@h-repic.co.jp](mailto:sales@h-repic.co.jp)

### India

**GEEBEE**  
INTERNATIONAL

GEEBEE International  
[www.geebinternational.com](http://www.geebinternational.com)  
[info@geebinternational.com](mailto:info@geebinternational.com)

### China

**CONVe-YI** 北京科维泰信

Beijing Conveyi Limited  
[www.conveyi.com](http://www.conveyi.com)  
[sales@conveyi.com](mailto:sales@conveyi.com)

### South Korea

**SEYOUNG**

Seyoung Co., Ltd  
[www.seyoungsys.com](http://www.seyoungsys.com)  
[apark@seyoungsys.com](mailto:apark@seyoungsys.com)

---



**TABLE OF CONTENTS**

INITIAL INSPECTION .....3

WARRANTY .....3

ASSISTANCE .....3

SERVICE PROCEDURE .....3

RETURN PROCEDURE .....4

SAFETY INSTRUCTIONS .....4

BEAM POSITION MONITOR SYSTEM .....5

QUICK CHECK.....6

    Beam displacement.....8

    Explore the dynamic range .....10

ADVANCED CHECK .....10

    X and Y output signals for single pass.....13

    Further tests.....13

ALGORITHM, SENSITIVITY & POLARITY .....14

    Orthogonal pickups version.....14

    Rotated pickups version .....14

ON-BOARD ADJUSTMENTS .....15

    Procedure .....15

    Users’ adjustments.....16

BB-BPM PRINCIPLE OF OPERATION .....17

BLOCK DIAGRAM .....18

PERFORMANCE.....19

SIGNALS .....20

    Pickup Inputs .....20

    Output narrowband signals .....20

    Output wideband signals.....20

    Optional Output wideband signals .....20

    Input and output signals.....21

    Common external controls.....21

BPM CABLES LAYOUT & INSTALLATION .....21

    Cable layout .....21

BB-BPM-E & BPM-RFC CHASSIS CONNECTORS PINS ALLOCATION REV. 3.3 .....22

BPM CHASSIS .....23

FRONT-END FILTER & AMPLIFIER BB-BPM-FEFA .....24

Outlook.....	25
Purpose of BB-BPM-FEFA .....	25
Connecting BB-BPM-FEFA.....	26
Gain.....	26
Gain vs. frequency .....	27
-1 dB compression point .....	28
Gain matching.....	28
Input characteristics.....	29
Output characteristics .....	29
Controls .....	29
FO specifications.....	29
Power consumption .....	29
Enclosure dimensions .....	29

## **INITIAL INSPECTION**

It is recommended that the shipment be inspected immediately upon delivery. If it is damaged in any way, contact Bergoz Instrumentation or your local distributor. The content of the shipment should be compared to the items listed on the invoice. Any discrepancy should be notified to Bergoz Instrumentation or its local distributor immediately. Unless promptly notified, Bergoz Instrumentation will not be responsible for such discrepancies.

## **WARRANTY**

Bergoz Instrumentation warrants its beam current monitors to operate within specifications under normal use for a period of 12 months from the date of shipment. Spares, repairs and replacement parts are warranted for 90 days. In exercising this warranty, Bergoz Instrumentation will repair, or at its option, replace any product returned to Bergoz Instrumentation or its local distributor within the warranty period, provided that the warrantor's examination discloses that the product is defective due to workmanship or materials and that the defect has not been caused by misuse, disassembly, neglect, use of faulty part, accident or abnormal conditions, repair made by the customer, or operations. Damages caused by ionizing radiations are specifically excluded from the warranty. Bergoz Instrumentation and its local distributors shall not be responsible for any consequential, incidental or special damages.

## **ASSISTANCE**

Assistance in installation, use or calibration of Bergoz Instrumentation beam current monitors is available from Bergoz Instrumentation, 01630 Saint Genis Pouilly, France. It is recommended to send a detailed description of the problem by email to [info@bergoz.com](mailto:info@bergoz.com).

## **SERVICE PROCEDURE**

Products requiring maintenance should be returned to Bergoz Instrumentation or its local distributor: The purchaser/customer must ask for a RMA (Return Material Authorization) number to Bergoz Instrumentation or its local distributor before return of goods. Bergoz Instrumentation will repair or replace any product under warranty at no charge.

For products in need of repair after the warranty period, Bergoz Instrumentation will assess the technical issue and send a quote to the purchaser/customer. The purchaser/customer must provide a purchase order before repairs can be initiated. Bergoz Instrumentation can issue fixed price quotations for most repairs.

## RETURN PROCEDURE

All products returned for repair should include a detailed description of the defect or failure as well as name, phone number and email of a contact person to allow further inquiry. Contact Bergoz Instrumentation or your local distributor to determine where to return the product. Returns must be notified by email prior to shipment.

The shipment of a product under warranty or out of warranty back to the factory is paid by the user/customer, including the customs fees. The return of this repaired product under warranty back to the customer is paid by Bergoz Instrumentation.

Return of product out of warranty should be made prepaid or will be invoiced. Bergoz Instrumentation will not accept freight-collect shipments. Shipments should be made via UPS, FedEx or DHL. Within Europe, the transportation services offered by the national Post Offices can be used. The delivery charges or customs clearance charges arising from the use of other carriers will be charged to the customer.

## SAFETY INSTRUCTIONS

This instrument is operated from the mains power supply. For safe operation, it must be grounded by way of the grounding conductor in the power cord. Use only the fuse specified. Do not remove cover panels while the instrument is powered. Do not operate the instrument without the cover panels properly installed.

Chassis originally shipped to U.S. or Canada feature AC mains power entry modules where the Phase is fused and the Neutral unfused, as is the rule.

Chassis to other destinations but U.S. and Canada feature AC mains power entry modules where both Phase and Neutral are fused.

When a chassis with unfused Neutral shall be used outside the U.S. and Canada, fuse configuration must be modified so that both Phase and Neutral will be fused:

The Power entry module must be opened, the Phase fuse must be removed, the fuse holder must be flipped; its reverse side presents two slots where two new fuses must be inserted, one in each slot. The fuses rating must be same as the Phase fuse that was removed.



## BEAM POSITION MONITOR SYSTEM

This manual applies to the Baseband BPM only: BB-BPM

Other models, e.g., MX-BPM, LR-BPM, S-BPM, BPM-AFE are described in other manuals.

The Baseband BPM system includes:

<i>Description</i>	<i>Order code</i>
Baseband BPM electronics module	BB-BPM-E
Output with sum of A, B, C and D logs, option	BB-BPM-SUM
Options are installed onto the BB-BPM-E board	
Front-end Amplifier and Filter	BB-BPM-FEFA
This component is described in Annex BB-BPM-FEFA at the end of this manual.	

### Accessory

19" chassis with power supply	BPM-RFC/XX
	XX is number of wired stations

Check the fuse configuration, that it corresponds to your national regulations.

The 19" BPM-RFC chassis fuse compartment is configured at the time of shipment according to its destination:

- North America: phase wire fused, mains ground wire unfused.
- All other destinations: both mains  
To verify which fuse configuration is installed on your chassis, pull out the removable fuse block, using a small screwdriver.
- The unfused ground configuration has a shorting bar and a 2A 6x32 fuse.
- The configuration with both AC lines fused is equipped with two 2A 5x20 fuses.  
To change this configuration, unscrew the fuse holder off the fuse block, flip the holder over and screw it back onto the fuse block. Insert the following fuses:
  - For unfused ground configuration: one 2A 6x32 fast fuse.
  - For both AC lines fused configuration: two 2A 5x20 fast fuses.

The power supplies in BPM-RFC/XX chassis are autoranging from 98V...264V.

## QUICK CHECK

You can check immediately that your BB-BPM system is working.

### Setup

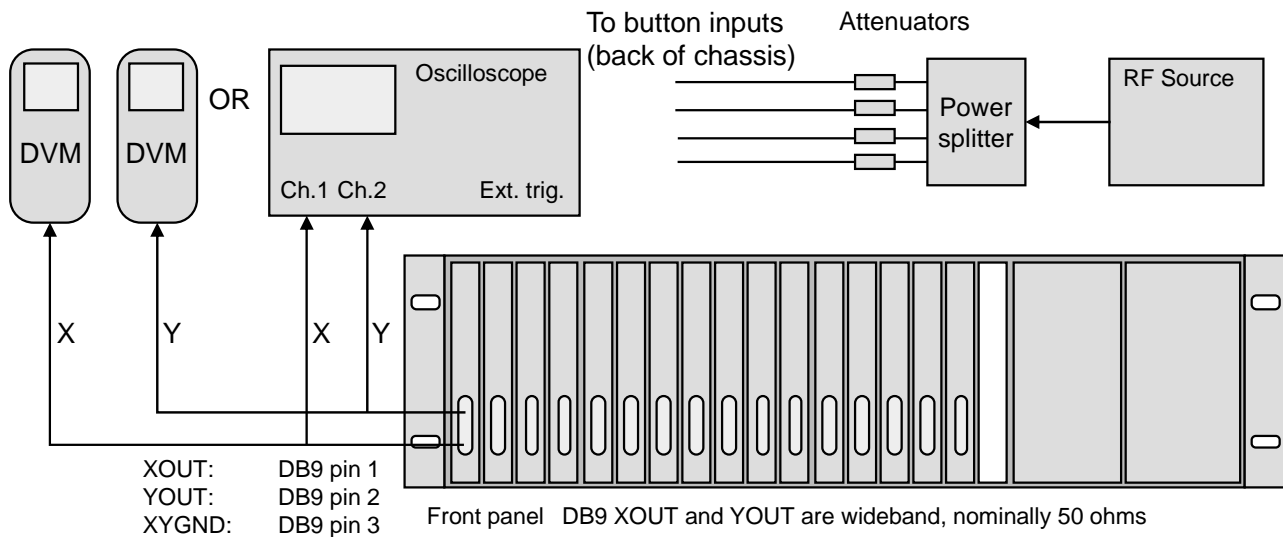

To display X and Y signals, either use two DVMs, or an oscilloscope. The front-panel DB9 outputs are 50 ohms nominal impedance. Attach the equipment together as shown above.

Set the DVMs on Volt-DC, or the oscilloscope on:

- Time base on 0.2 ms / div., free running,
- Channel 1 to Xout signal, sensitivity 0.2 V / div.
- Channel 2 to Yout signal, sensitivity 0.2 V / div.

Set the RF source within the BB-BPM-E:

- Operating frequency range, e.g., 1 MHz
- Amplitude  $\approx$  -10 dBm.

Use 4 similar attenuators, e.g.,  $\approx$  3 dB. The same test can be done with 5 and 10 dB. Please note that attenuators are seldom more precise than  $\pm 0.1$  dB. This will be reflected upon the BB-BPM X and Y readings.

Please note that signals applied to BB-BPM-E inputs will be attenuated by the 4-way splitter: 4-way transformer-type splitters typically attenuate by 7 dB, 4-way resistive splitters or cascaded 2-way splitters attenuate by 12 dB.

Connect the Test Kit or 19" BPM-RFC chassis to AC mains; the DVM (or oscilloscope) will display X and Y values.

If the RF signals applied to all four BB-BPM inputs were exactly equal, and if the BB-BPM-E module were perfect, the values of X and Y would be exactly 0 Volt.

This is generally not the case, X and Y will be many 10s or even 100s of millivolts off.

You can determine how much of this offset is caused by attenuator inequality:  
Swap the attenuators A and C, then B and D and observe the offset change.

You can determine how much of this offset is caused by power splitter imbalance:  
Instead of connecting attenuator A to power splitter output 1, connect it to output 3  
and connect attenuator C to output 1.  
Do the same for attenuators B and D with power splitter outputs 2 and 4.

The next tests will consist of:

- Simulating beam displacements cause by inputs imbalance of 6 dB, 10 dB and 14 dB
- Exploring the BB-BPM-E dynamic range by varying the RF source output.

### Beam displacement

The RF source output power should be in the range -10dBm ... -35 dBm

The BB-BPM-E on-center sensitivity is factory-set to 55.5 mV per dB of signal difference between opposite pickups. For pickups with small subtending angle (e.g. buttons), 6 dB corresponds to beam displacement equal to 1/6 of vacuum chamber radius. As the beam goes off center, this sensitivity becomes lower due to the algorithm  $X = \text{Log} (A/C)$ . Please consider that the BPM pickup sensitivity becomes higher as the beam goes off center, and one non-linearity tends to compensate the other.

Modules BB-BPM-E are manufactured in two versions:

- For orthogonally placed pickups: up, down, left and right
- For rotated pickups: upper-right, upper-left, lower-left and lower-right

Before simulating a beam displacement, start by noting the X and Y zero offsets, using four equal attenuators:

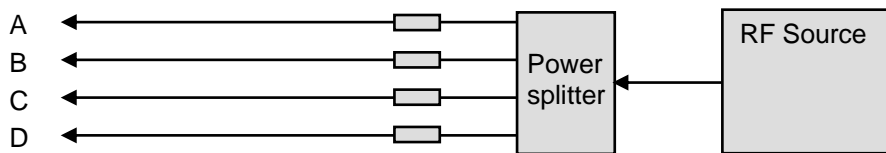

Then simulate the displacement by removing an attenuator from one input and inserting it in the opposite input: A <=> C, and B <=> D.

Example:

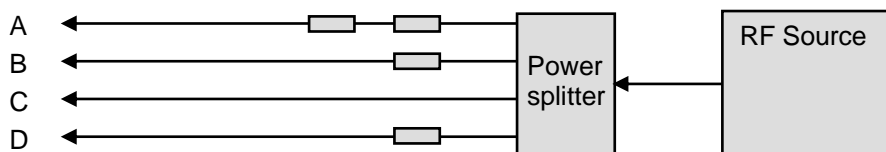

Attenuator C is removed from input C, and added to input A, thus simulating a displacement of the beam towards C (stronger signal on C pickup).

The following combinations can be tried, yielding the X and Y values listed here. Please note these are displacements. Take the zero offsets due to power splitter imbalance and attenuators inequality into consideration.

Table of X/Y output voltage vs. input power

Input	Attenuators	Equivalent displacement	Rotated pickups	Orthogonal pickups
A	3 + 3	1/6 of radius towards C		
B	3		X = -0.245 V	X = -0.347 V
C	0		Y = -0.245 V	Y = 0 V
D	3	(button pickups << chamber diameter)		
A	3 + 3	1/6 of radius towards C		
B	3 + 3	1/6 of radius towards D	X = 0 V	X = -0.347 V
C	0		Y = -0.490 V	Y = -0.347 V
D	0	(button pickups << chamber diameter)		
A	5 + 5	1/4 of radius towards C		
B	5		X = -0.407 V	X = -0.576 V
C	0		Y = -0.407 V	Y = 0 V
D	5	(button pickups << chamber diameter)		
A	5 + 5			
B	5 + 5		X = 0 V	X = -0.576 V
C	0		Y = -0.814 V	Y = -0.576 V
D	0	(button pickups << chamber diameter)		
A	10 + 7	1/3 of radius towards C		
B	10		X = -0.570 V	X = -0.806 V
C	3		Y = -0.570 V	Y = 0 V
D	10	(button pickups << chamber diameter)		

The above voltages are representations of the algorithms:

- $X = K_X \text{Log}(A/C)$  and  $Y = K_Y \text{log}(B/D)$  for orthogonal pickups, and
- $X = K_X (\text{Log}(A/C) + \text{Log}(B/D)) \cos \alpha$ , and  $Y = K_Y (-\text{Log}(A/C) + \text{Log}(B/D)) \sin \alpha$  for rotated pickups.

Where:  $\alpha$  is the tilt angle of the pickups,  
 $K_X$  and  $K_Y$  are set to 1.1513 Volts

Note: This value was chosen because it corresponds to a difference-over-sum ratio equal to 1 V, for small amplitude off-center displacements. E.g. 0.001 V for 0.005 x R.

To maintain the condition  $A+C = B+D$  when two attenuators are cascaded in one input, their attenuation should be increased to compensate for the BPM pickup non-linearity also called "pin cushion effect". E.g., 3+3 dB should really be ~6.5 dB with ~0.5 dB in opposite input. 5+5 dB should really be ~11.4 dB and 1.4 dB in opposite input, 10+10 dB should really be ~25 dB and ~5 dB in opposite input.

### Explore the dynamic range

Set the input attenuators in such way that X and Y are off center.

Vary the power from the RF source to simulate beam intensity variations.

Explore the range from +7 dBm down to -70 dBm.

Remember that 4-way transformer-type splitters absorb typically 7 dB and resistive splitters absorb 12 dB.

While the RF source output power is changed, observe the intensity dependence of X and Y outputs on the voltmeters. The X and Y output voltages vary with input power applied to the BB-BPM-E inputs:

The plot hereunder is taken with BB-BPM-E set for orthogonal pickups:

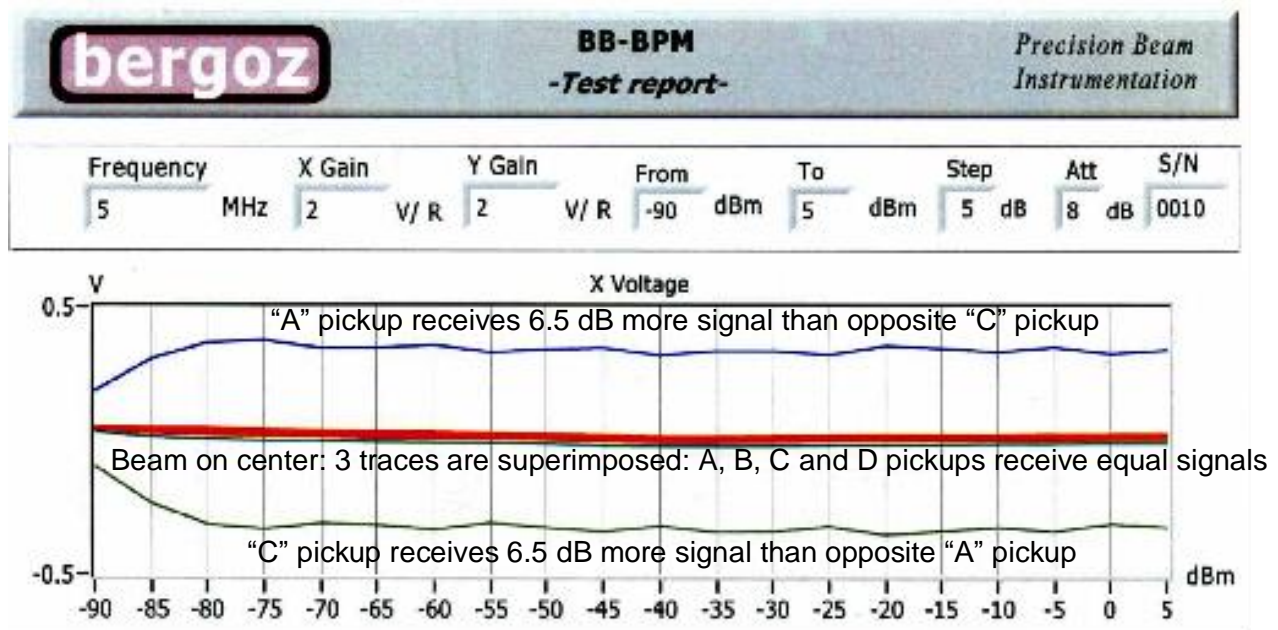

### ADVANCED CHECK

Before performing the advanced check, it is recommended to get familiar with BB-BPM in CW (Continuous Wave) mode as described in earlier chapter "Quick Check".

After the initial setup, the checking procedure is the same.

Advanced check will make you familiar with the BB-BPM behavior in single pass mode:

- Select a pulse generator capable of making short pulses with ca. 1nC charge in 50 ohms.

The generator output pulse length should not exceed  $T/2$ , where  $T$  is the period of the BB-BPM-E operating frequency.

Example: BB-BPM-E/1-10MHz. Shortest period = 100ns, the pulse length should not exceed 50 ns.

If 50 ns is chosen, pulse amplitude would be 1V in 50 ohms, to make it 1 nC.

The examples hereafter use 1-ns pulses and 50V amplitude from a mercury pulse generator.

**Setup**

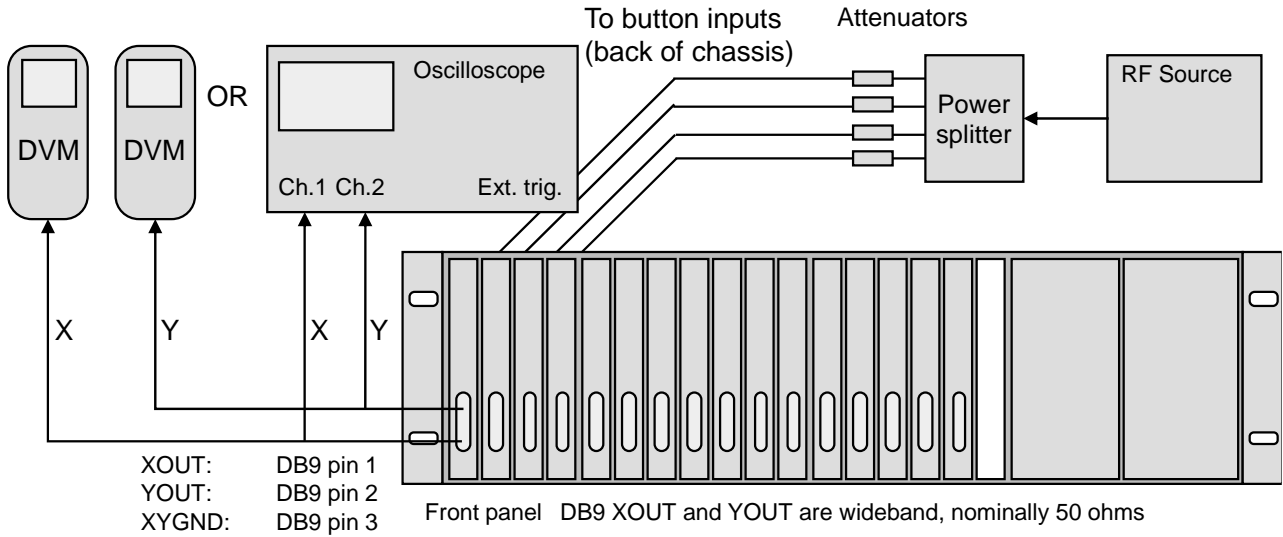

Remove the BB-BPM-E cover shield as described in the Quick Check.  
Place the BB-BPM-E module on a card extender type BPM-XTD.

Use an asymmetrical combination of attenuators to simulate beam off center.

Start the pulse generator and look for the Beam Trigger signal on the oscilloscope.

Observe the signals on the BB-BPM-E board with a high-impedance probe. It can be 500-ohm, or -20dB high-Z.

With the probe, take the signal "LogA" off the BB-BPM-E board:

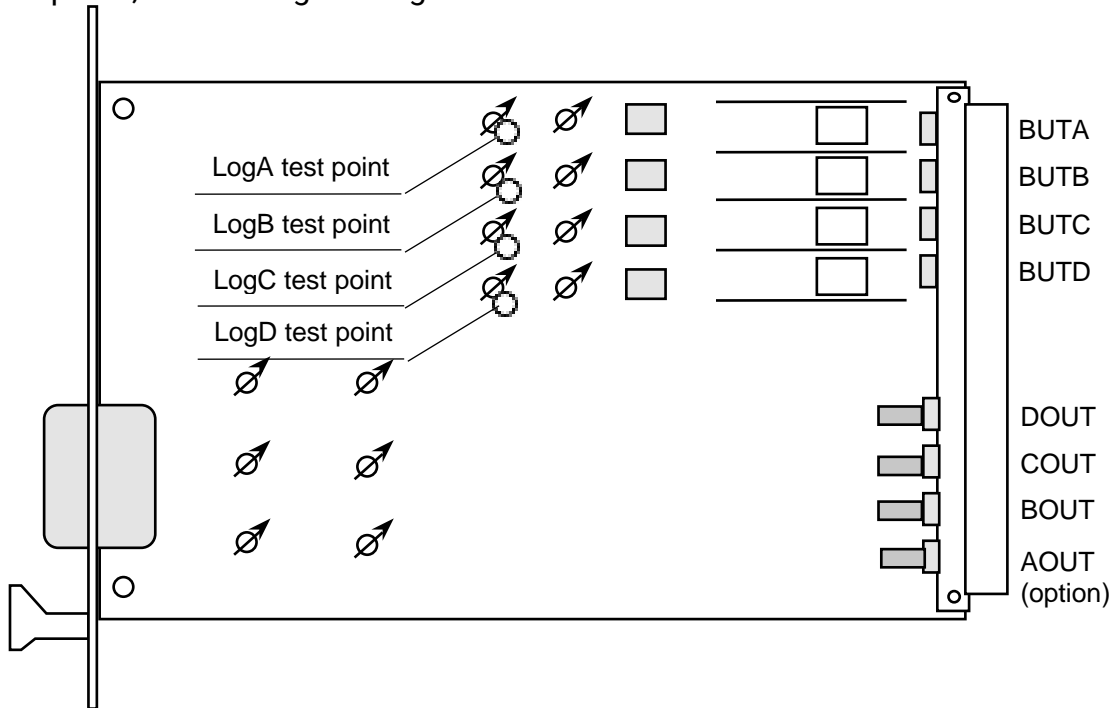

The signals on the oscilloscope will look like:

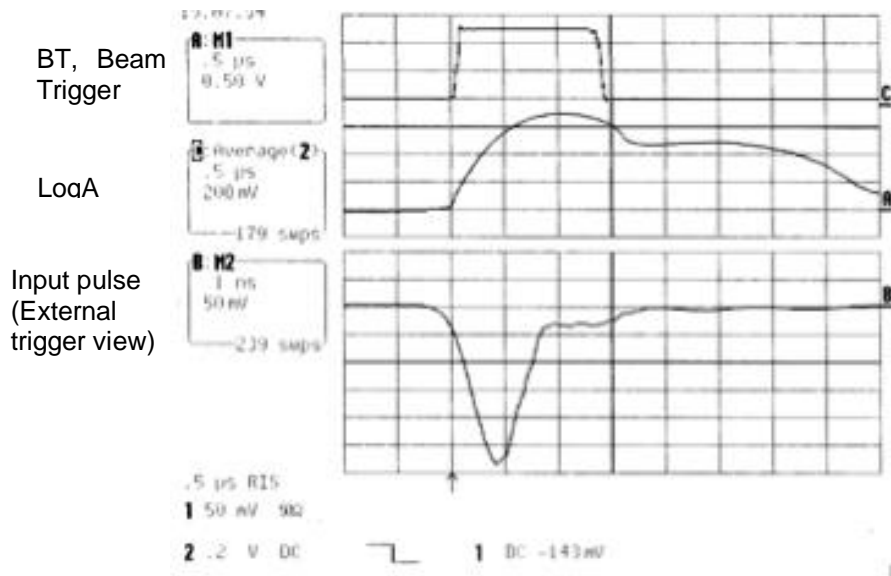

Observe the Beam Trigger BT rising  $\sim 1$  us before the apex of LogA.

Note: These waveforms are taken from BB-BPM-E models equipped with AD8307 log amplifiers. Other BB-BPM-E models –depending on their frequency range– may be equipped with other log amplifiers, e.g., AD8313, AD8318. With those other log amplifiers, the waveform may be slightly different.



### X and Y output signals for single pass

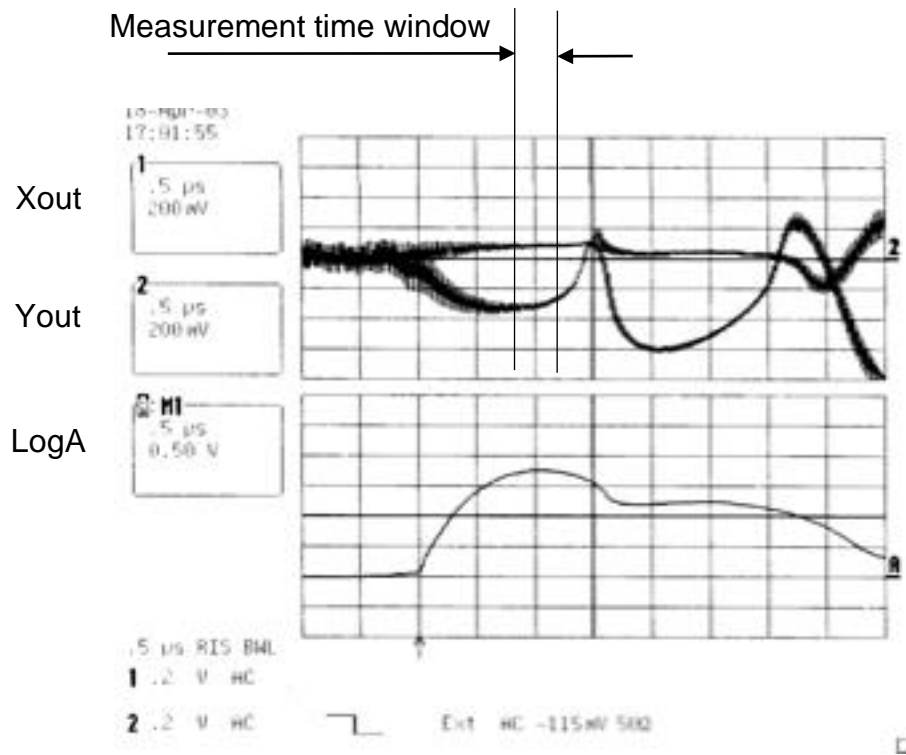

Observe the Xout and Yout signals represent X/Y positions for ~500 ns about LogA pulse apex.

LogA apex is itself ~1 us after Beam Trigger rising edge.

Observe the signals Xout and Yout are very noisy before the pulse is applied. It is characteristics of the logarithmic representation of large variations.

Note: These waveforms are taken from BB-BPM-E models equipped with AD8307 log amplifiers. Other BB-BPM-E models –depending on their frequency range– may be equipped with other log amplifiers, e.g., AD8313, AD8318. With those other log amplifiers, the waveform may be slightly different.

### Further tests

More tests can be conducted with other input attenuators configurations. The pulse amplitude from the Pulse Generator can be reduced to explore the dynamic range.

## ALGORITHM, SENSITIVITY & POLARITY

### Orthogonal pickups version

$$X = K_X \cdot \text{Log} (A/C)$$

$$Y = K_Y \cdot \text{Log} (B/D)$$

Where  $K_X$  and  $K_Y$  are factory-set for on-center sensitivity 55.5 mV/dB

For pickup electrodes with small  $\Phi$ , 55.5 mV corresponds to 1/36 of radius beam displacement.

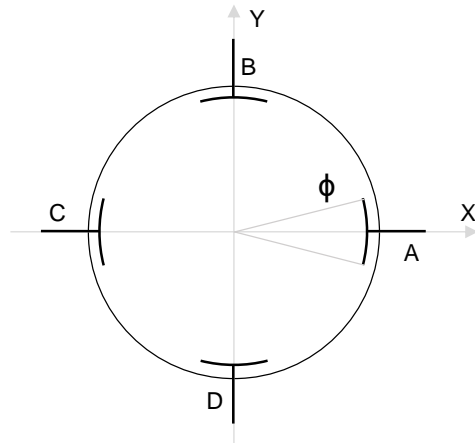

### Rotated pickups version

$$X = K_X \cdot [\text{Log} (A/C) \cdot \cos \alpha - \text{Log} (B/D) \cdot \sin \alpha]$$

$$Y = K_Y \cdot [\text{Log} (A/C) \cdot \sin \alpha + \text{Log} (B/D) \cdot \cos \alpha]$$

Where  $K_X$  and  $K_Y$  are factory-set for on-center sensitivity 55.5 mV/dB of difference between opposite pickups.

When  $\cos \alpha = \sin \alpha = 1/\sqrt{2}$ , the sensitivity in X and Y equals 55.5 mV/ $\sqrt{2} = 39.2$  mV.

For pickup electrodes with small  $\Phi$ , 39.2 mV in X or Y corresponds to 1/36 of radius beam displacement along the X, resp. Y axis

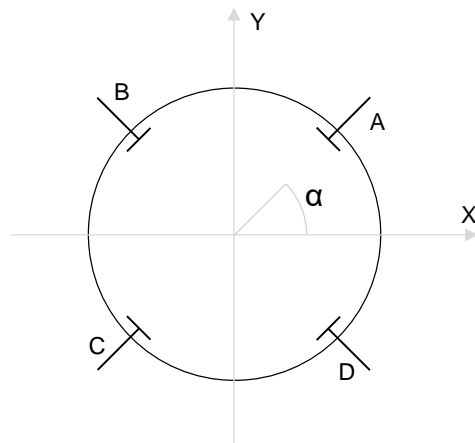

Note: Pickups with larger  $f$ , such as stripline and shoebox, have higher coupling impedance (they collect more signal from the beam) but lower sensitivity to beam displacement.

Pickup sensitivity increases with  $f$  as  $\sin(f/2) / f^1$ .

<sup>1</sup> Log-ratio Signal-Processing Technique for Beam Position Monitors, Robert E. Shafer, Proceedings of the Fourth Accelerator Instrumentation Workshop, Berkeley 1992.  
AIP Conf. proceedings No. 281, pages 120-128.

## ON-BOARD ADJUSTMENTS

The BB-BPM-E module is equipped with many on-board potentiometers. Some can be readjusted easily by the users, while others require precise tools and procedures for their adjustment. The function of each adjustment is described hereafter.

### Procedure

Proceed as described in “Quick Check”.

Using the table-top test kit (BPM-KIT) is the easiest setup to readjust potentiometers.

An alternative is to extend the BB-BPM-E module out of its chassis, using the card extender (BPM-XTD).

Note: No damage will occur to BB-BPM-E modules if they are inserted or removed while the power is on.

Note: The card extender has unequal button-to-button attenuations. It introduces an offset in X and Y. The card extender offset was measured at the time of shipment. To recheck it, measure the X and Y offsets with and without extender.

To adjust the on-board potentiometers, remove the shield:

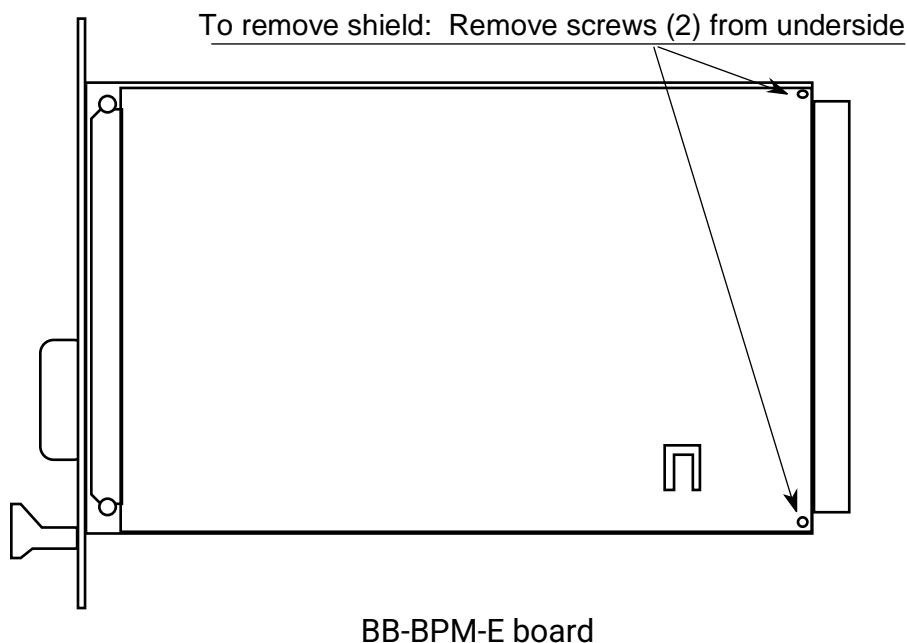

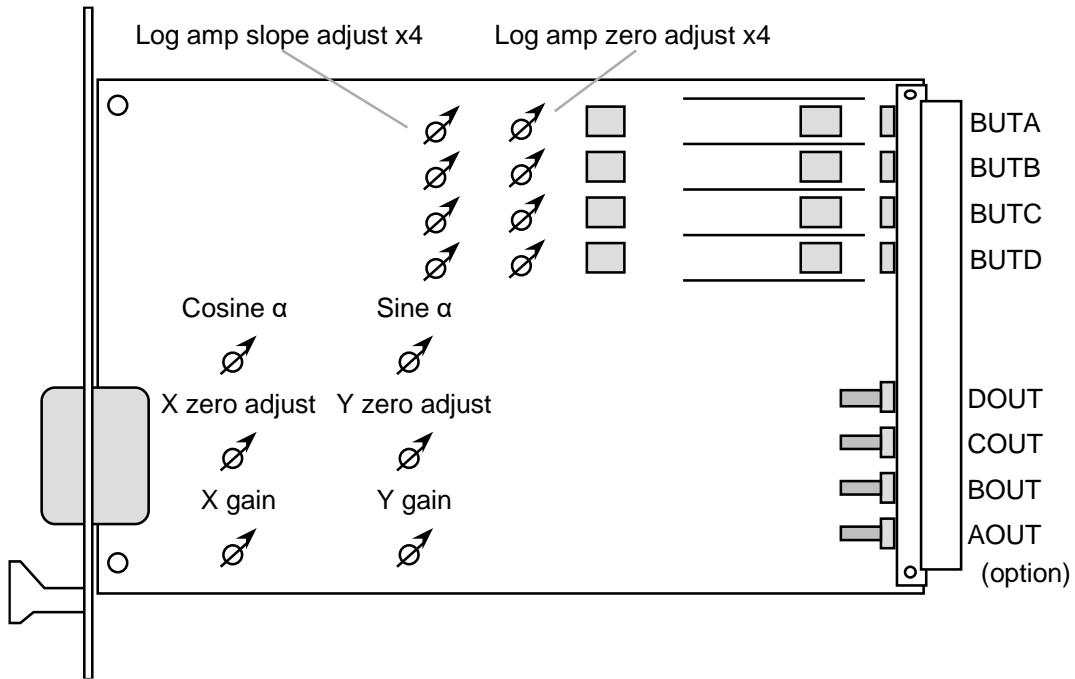

It is not recommended to change the following adjustments:

Log amplifier zero adjust      to match the origin of two opposite log amplifiers  
 Log amplifier slope adjust      to match the slope of all four log amplifiers

**Users' adjustments**

Note: To adjust these potentiometers, use a screwdriver with a ceramic tip. A metal tip changes the signal!

- Cosine α and Sine α      Sets the pickups tilt angle (both are 1/√2 factory-set) .  
    Rotated pickups only.
  
- X gain & Y gain      Sets the X and Y gains  
    X and Y gains factory settings:  
    347mV for 6 dB between opposite orthogonal pickups (1 on1),  
    490mV for 6 dB between opposite rotated pickups (2 on 2).
  
- X zero adjust      Matches the Log (A/C) input levels
  
- Y zero adjust      Matches the Log (B/D) input levels

## BB-BPM PRINCIPLE OF OPERATION

The signals from the pickup electrodes are processed simultaneously thru four independent channels. Each channel consists of an input band-pass filter, followed by an amplification chain with logarithmic response.

When a single short pulse is applied to the band-pass filter, it will oscillate at its own resonant frequency for about 250 ns, allowing enough time for the logarithmic amplifier to detect the log of its envelope.

Each amplifying chain produces a signal which peak amplitude is proportional to the log of the input signal, be it a single pulse, a pulse train, or a continuous wave.

Log signals from opposite pickup electrodes are deducted from one another to obtain  $\text{Log}(A) - \text{Log}(C) = \text{Log}(A/C)$  which is said to be a very faithful representation of beam displacement between two pickup electrodes.

If the pickup electrodes are placed along the axes in which the beam displacement is to be measured, the displacement  $X = K_X \text{Log}(A/C)$ , directly. The  $K_X$  gain is obtained by an amplifier with adjustable gain. The same goes for the Y axis.

If the pickup electrodes are placed along axes rotated as compared to the beam position measurement axes, the A-C and B-D axes must be rotated to obtain the beam displacement values along X and Y. This is achieved by applying the cosine of the tilt angle to one axis and the sine of the tilt angle to the other axis, before summing them. This is done wideband with >10 MHz response.

Schematic representation of the log-ratio BPM, an original concept of Robert E. Shafer:

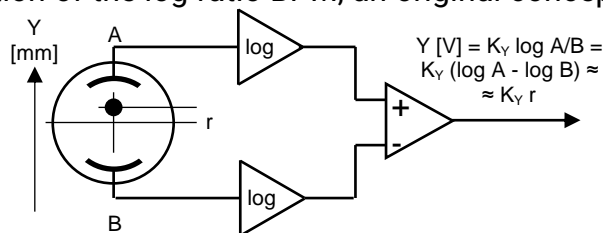

Position measured by this method is more linear, over a wider range, than difference-over-sum.

**BLOCK DIAGRAM**

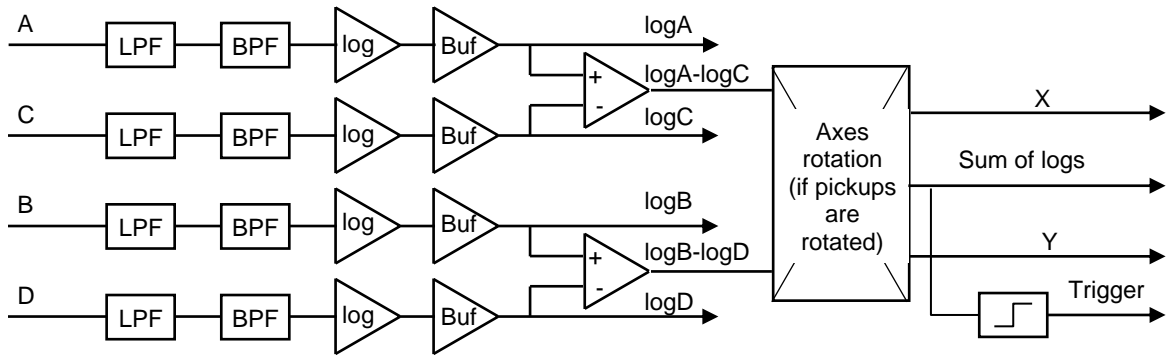

**PERFORMANCE**

Performance with CW input signals is reported for each module. Plots are attached to the Certificate of Calibration. Example:

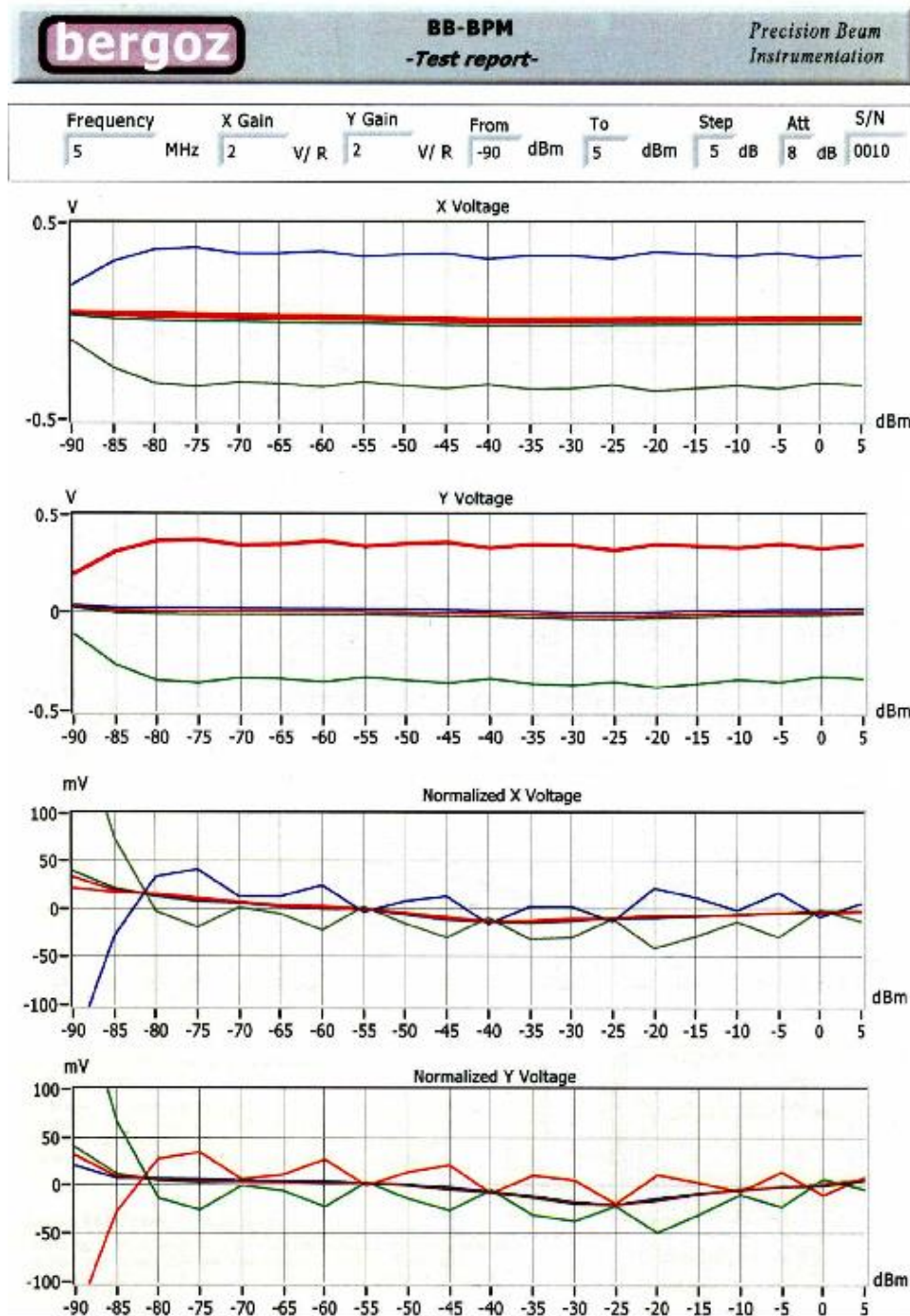

Note: X and Y signal displays are limited to ~1 kHz (10 kHz on option) by the virtual instrument LabVIEW.

## SIGNALS

### Pickup Inputs

BUTA	Pickup inputs A, B, C, and D. Impedance 50Ω.
BUTB	See Algorithms, Sensitivity & Polarity, this manual, for pickup assignment.
BUTC	
BUTD	

### Output narrowband signals

	(0...200 Hz) High-impedance (0...10 kHz on option)
XOUT	X displacement. Range -2V...0...+2V. 0 Volt represents pickup center.
YOUT	Y displacement. Range -2V...0...+2V. 0 Volt represents pickup center.
XYGND	Analog ground for the above signals.

XOUT and YOUT signals should be connected to ADC, preferably via a twisted pair cable for better EMI immunity.

### Output wideband signals

	(0...5 MHz) 50-ohm impedance
XOUT	X displacement. Range -2V...0...+2V. 0 Volt represents pickup center.
YOUT	Y displacement. Range -2V...0...+2V. 0 Volt represents pickup center.
XYGND	Analog ground for the above signals.

### Optional Output wideband signals

SUM	Sum of logs (LogA + LogB + LogC + LogD) Equal to log of beam intensity, for centered beam.
GND	Ground for above signal(s).



## Input and output signals

Input and output signals hereafter are specific to each BPM module

SUM	Sum of logs (LogA + LogB + LogC + LogD) Equal to log of beam intensity, for centered beam.
GND	Ground for above signal(s).
BT	Beam Trigger. >500-mV positive going pulse with rising edge ~1 us before log signals reach their apex.
BT*	Beam Trigger. >500-mV negative going pulse with falling edge ~1 us before log signals reach their apex.
BTGND	Ground for BT and BT* signals

## Common external controls

Common external controls are controls which are common to all BPM modules in a BPM chassis.

BB-BPM-E does not feature any external control.

## BPM CABLES LAYOUT & INSTALLATION

### Cable layout

Unnecessary intermediate connectors should be avoided. When for practical reasons patch-panels must be used, the patch panel should not ground the body of bulkhead connectors. Every cable segment should be passed through tubular common-mode filters (also called "chokes"). Common-mode filters must be placed at each end of every cable segment. A cable segment is a stretch of cable terminated at each end by a connector. To be effective over a wide spectrum of EM and RF interference, each common-mode filter should be composed of two tubes, cores or "beads" with the cable passing through: One tube of MnZn ferrite and one core of iron-based nanocrystalline alloy, e.g., Hitachi Metal Finemet.

The four cables pertaining to the same BPM stations must be laid side by side. Cables, BPM chassis and modules should be kept away –as much as possible– from RF equipment, klystrons, cavities.

Connectors must be chosen carefully to match the cable used. Connectors manufacturer's instructions must be followed meticulously. If cable layout is subcontracted, subcontractors must be informed of the extreme reliability expected from these cables. All cables with connectors must be checked before installation with a network analyzer, up to twice the operating frequency at least.

BB-BPM-E modules must be installed in an RF-shielded chassis.

Note: Unlike most BPM electronics, the BB-BPM-E module does not require the BPM RF signals to be in phase. Cables do not need to be phase-adjusted. The BB-BPM-E module tolerates any phase change, even 180°.

**BB-BPM-E & BPM-RFC CHASSIS CONNECTORS PINS ALLOCATION REV. 3.3**

DB15 female connector on BPM-RFC rear panel (one connector per BPM station)					
DIN41612M BB-BPM-E module rear connector					
DB9 female connector on BB-BPM-E front panel					
<b>RF INPUTS</b>					
Input A	BUTA			b2*	
Input B	BUTB			b5*	
Input C	BUTC			b8*	
Input D	BUTD			b11*	
*Coaxial insert 1.0/2.3 type					
<b>WIDEBAND OUTPUT SIGNALS</b>					
X output	XOUT	1			
Y output	YOUT	2			
Analog ground	XYGND	3			
<b>OPTIONAL OUTPUT SIGNALS</b>					
Sum of logs	SUM	5	b20		5
<b>NARROWBAND OUTPUT SIGNALS</b>					
X output	XOUT		a15		8
Y output	YOUT		a18		7
Analog ground	XYGND		a20		4
			a17		6
			b19		15
<b>SINGLE BUNCH TRIGGER OUTPUTS</b>					
Beam Trigger, positive-going	BT		c19		2
			c20		3
Beam Trigger, negative-going	BT*	9			
General ground	GND	4	b14		
<b>POWER SUPPLY</b>					
+ 15 V	+15V		c13		
- 15 V	-15V		c15		
Common	COM		c14		
Ground	GND	4	a19		
			b18		

**BPM CHASSIS**

The BPM-RFC/XX is available equipped for 1 up to 16 BPM stations. XX being the number of stations.

BPM-RFC/XX with less than 16 stations are partially equipped BPM-RFC/16. As a result, all BPM chassis are field-upgradable to the full 16-station chassis.

*Chassis rear view*

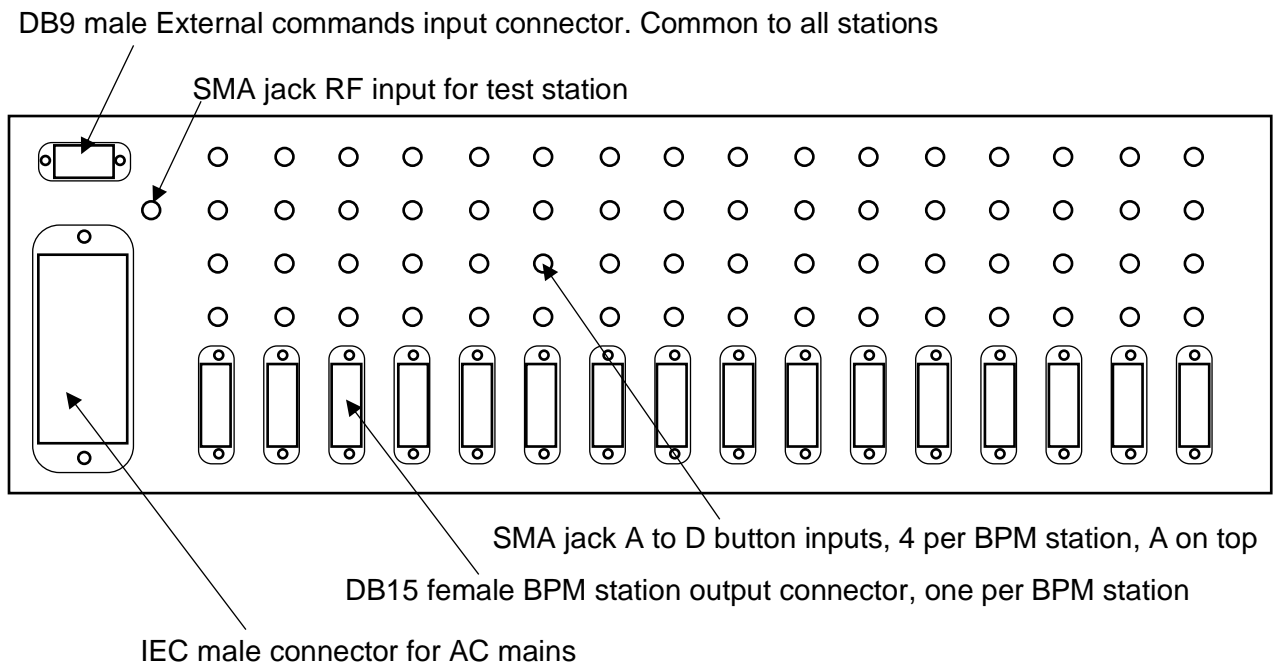

**Power Supply module**

AC mains voltage	Autoranging 98...132Vac and 185...265Vac with automatic range changeover
Power derating	No derating down to 85 Vac (at full chassis load)
Output	± 15 V, unequal loading tolerant
Power	75 W
Efficiency	84% at 220Vac, 81% at 110 Vac
Inrush current	limited to 10A max.
Dimensions	per DIN41494: 3U high, 8F wide, 160mm deep
Manufacturer	Delta Elektronika BV, the Netherlands
Model	75 SX 15-15

**BB-BPM-E rear connector**

Model	DIN41612M 24+8
-------	----------------

**FRONT-END FILTER & AMPLIFIER BB-BPM-FEFA**

**BB-BPM-E +15V jumper OFF position: Does NOT send +15V down the RF cables**

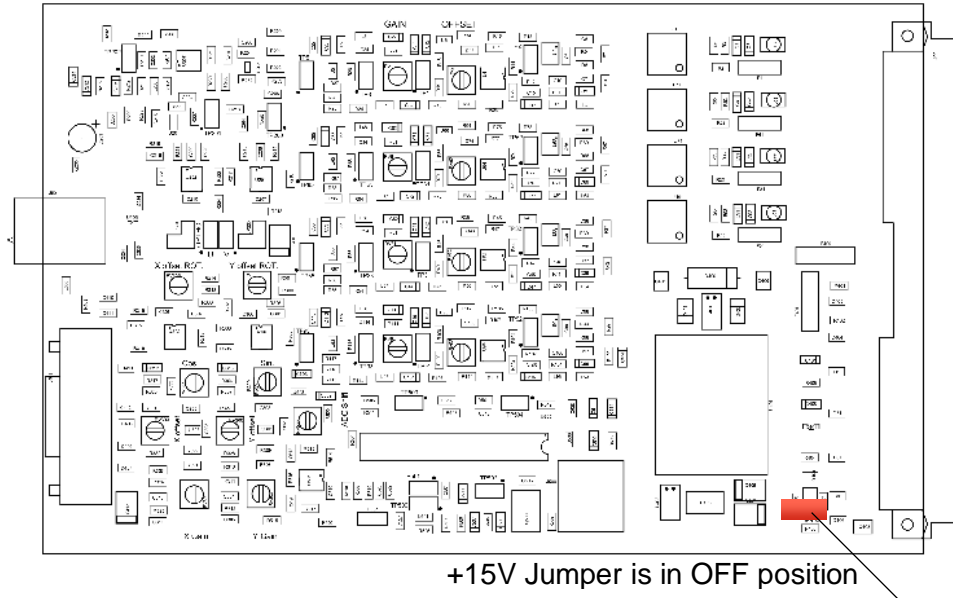

This is the ex-factory setting: +15V jumper OFF.  
 When BB-BPM-FEFA are not powered, their output is only noise.

**BB-BPM-E +15V jumper ON position: SENDS +15V down the RF cables**

When BB-BPM-E On-board +15V jumper in ON (Vertical orientation) the four BPM RF cables are POWERED with +15V.  
**DO NOT INSERT ANY ELEMENT IN CABLE** e.g., ATTENUATOR, SPLITTER, COMBINER, AMPLIFIER. The +15V power can blow these elements!  
 +15V is the power supply for BB-BPM-FEFA preamplifiers.

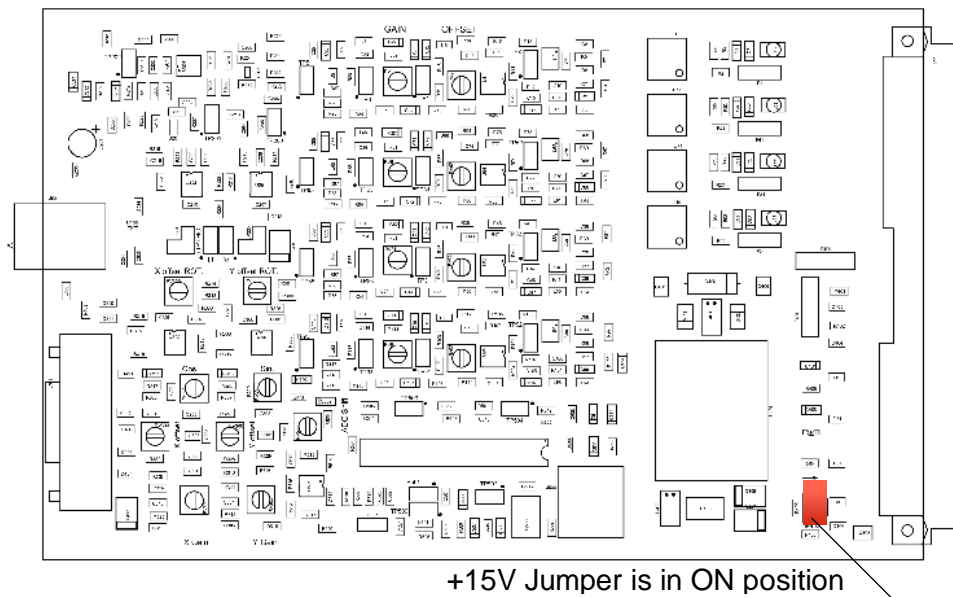

## Outlook

Top



Sides



### Purpose of BB-BPM-FEFA

BB-BPM-FEFA purpose is to capture the full amplitude of the beam bunch signal, even though the BPM electrode collecting the signal is much shorter than the physical bunch length. Such is the case of a shoebox BPM pickup on an ion synchrotron beam. Capturing the signal full amplitude is achieved by measuring the voltage induced on the electrode in a high impedance load.

## Connecting BB-BPM-FEFA

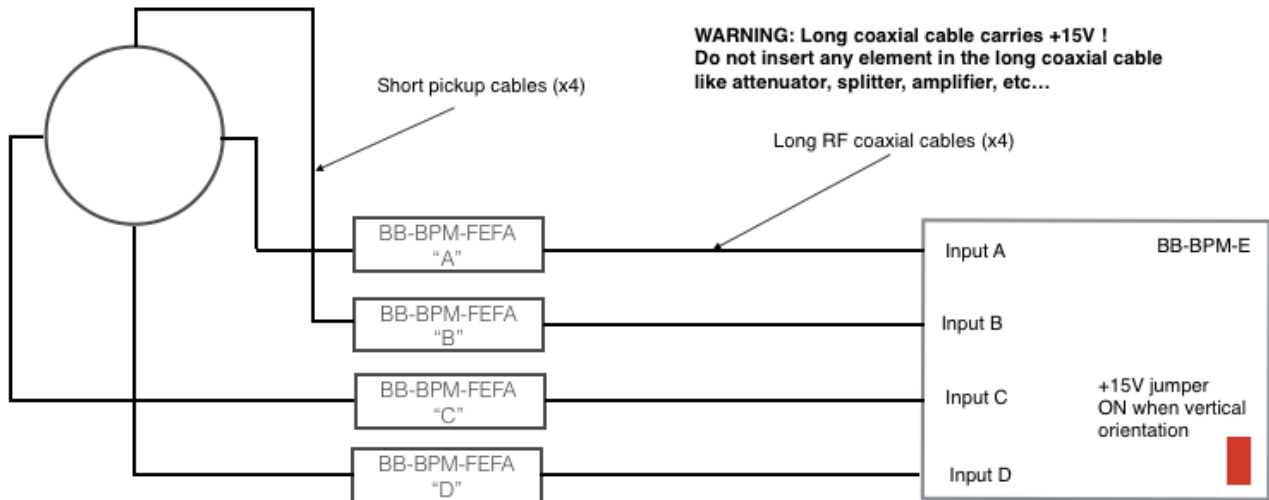

## Gain

Gain is obtained (a) by converting the charge collected by the BPM pickup electrode into a voltage, and (b) by a 50-ohm amplifier switched ON or OFF under the control of a fiber optic.

a) Charge-to-voltage conversion gain is the inverse of the impedance of the sum capacitance of BPM pickup electrode, BPM pickup electrode-to-FEFA cable and BB-BPM-FEFA input capacitance, at the beam frequency, in quadrature with BB-BPM-FEFA input resistance.

Note: Under calibration test conditions, BB-BPM-FEFA conversion gain  $\approx$  7dB.

b) BB-BPM-FEFA 50-ohm amplifier adds 33 dB to the conversion gain, for a total > 40dB. Exact gains are reported in the measurements attached to the Certificate of Calibration.

Gain LOW is BB-BPM-FEFA conversion gain only (FO control light OFF)

Gain HIGH is BB-BPM-FEFA conversion gain + 50-ohm amplification (FO control light ON).

### Gain vs. frequency

Gain and frequency bandwidth are customized to synchrotron specifications. Example:

- Top chart: HIGH gain in range 30 kHz to 30 MHz
- Lower chart: LOW gain in same range.

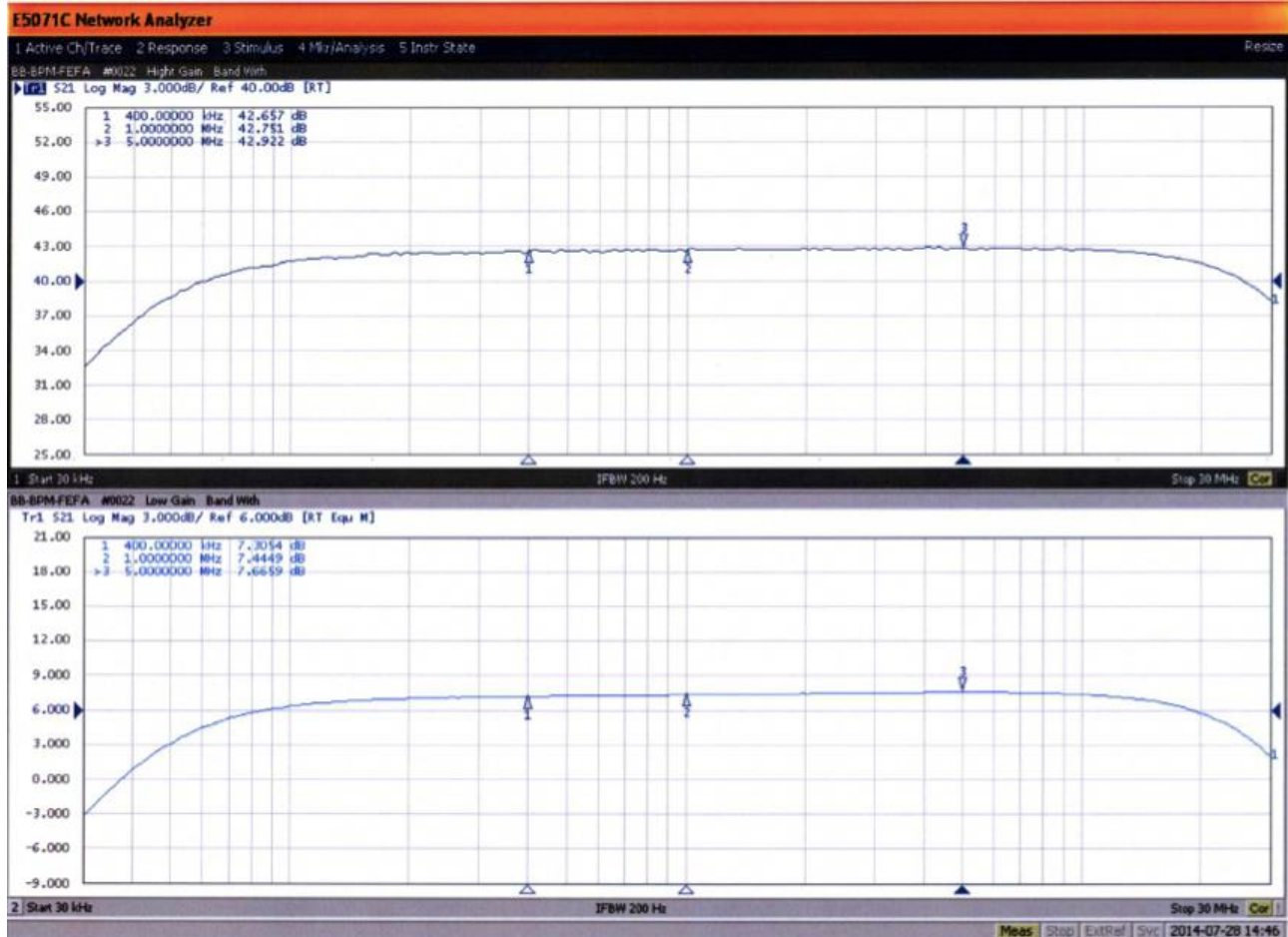

### -1 dB compression point

Gain compression can be a problem in position measurement when compression for opposing BPM pickup electrodes is different. Compression is monitored for each BB-BPM-FEFA:

- Power sweep thru L-pad from -55 dBm to +10 dBm at 1 MHz
- Top chart: HIGH Gain
- Lower chart: LOW Gain (conversion gain only).

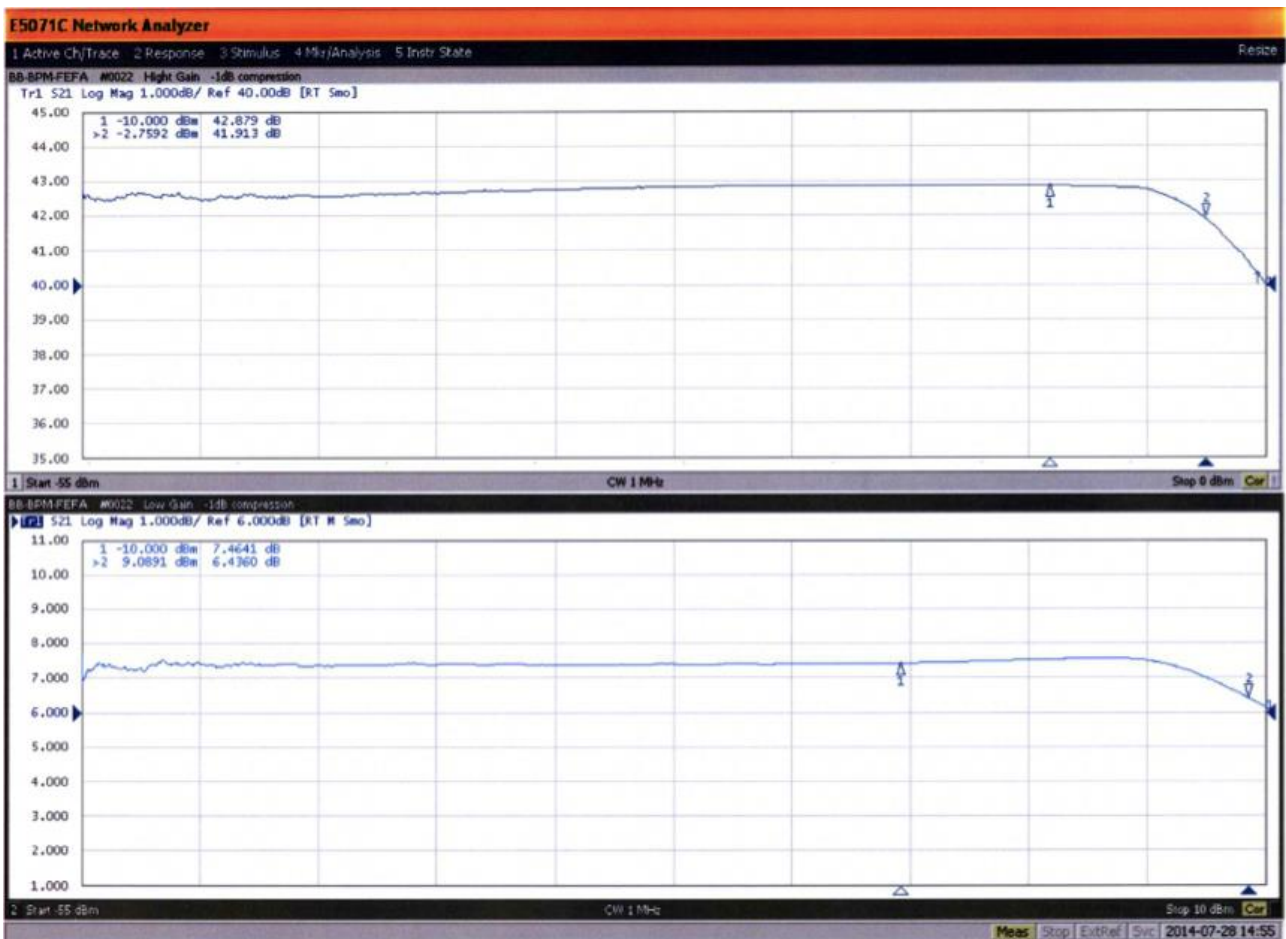

### Gain matching

BB-BPM-FEFA are gain/frequency matched in groups of four units to each BB-BPM-E board. Each BB-BPM-FEFA label indicates the BB-BPM-E serial number and input (A, B, C or D) it is matched to.



### Input characteristics

Connector SMA jack for 50-ohm coaxial cable, as short as possible.

Input impedance 400 kΩ + 80 pF

Note: Capacitance of BPM electrode to FEFA cable adds to the FEFA input capacitance: It must be minimized.

### Output characteristics

Beware: Output also acts as +15V power input!

Connector SMA jack for 50-ohm coaxial cable.

Output impedance 50 ohms

Note: The output SMA connector also serve as the input for the +15V power supply. +15V is supplied to FEFA by BB-BPM-E via the RF cable, when the +15V jumper on-board BB-BPM-E is ON (vertical orientation).

### Controls

Input control	GAIN-Trigger-input
FO input connector	IF-D97 Detector Photolog FO 400-1050nm, manufactured by Industrial Fiberoptics
Color	BLACK.
Light ON	Gain ON
Light OFF	Gain OFF
Default state	Gain OFF

Output control	GAIN-Trigger-output
FO output connector	IF-E98 manufactured by Industrial Fiberoptics
Color	BLUE.
Gain ON	Light ON
Gain OFF	Light OFF

Note: GAIN-Trigger-output purpose is to set the gain of next BB-BPM-FEFA

Note: GAIN-Trigger-output of last BB-BPM-FEFA may be used to check that all BB-BPM-FEFA received the GAIN-ON control signal.

### FO specifications

1-mm multimode simplex fiber coated.

E.g., ESKA-Series FO, e.g., Industrial Fiber Optics 810004.

### Power consumption

BB-BPM-FEFA +15V typical current:

HIGH Gain 90 mA

LOW Gain 77 mA

BB-BPM-FEFA power is supplied by BB-BPM-E via the coaxial cable.

### Enclosure dimensions

Length: 115 mm

Width 57 mm

Height 32 mm

More information and latest manuals revisions can be found on our website

[www.bergoz.com](http://www.bergoz.com)

If you have any questions, feel free to contact us by e-mail

[info@bergoz.com](mailto:info@bergoz.com)

