

USER'S MANUAL

MODEL: 3474-140

MODEL: 3474FG-140

250MM ELECTROMAGNET

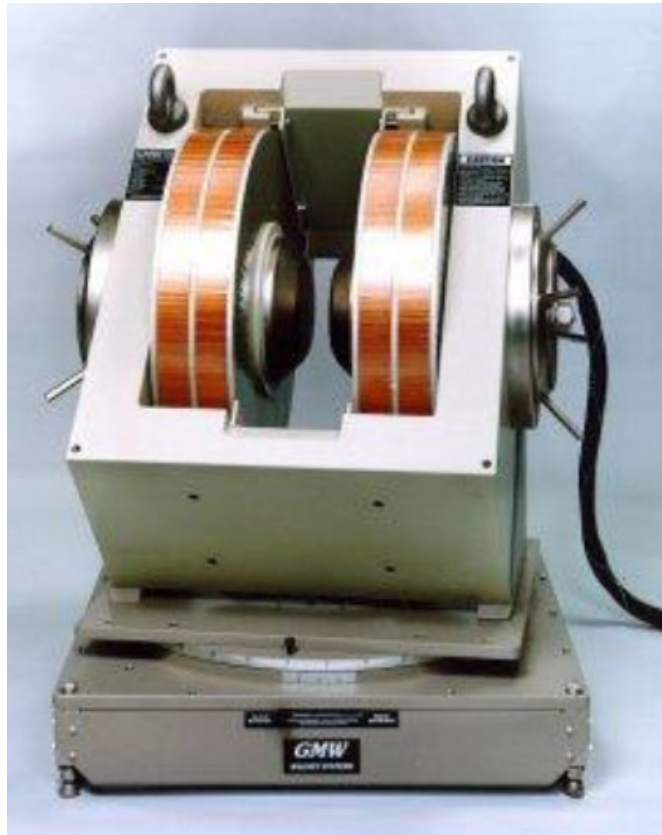

PROPRIETARY

THIS DOCUMENT CONTAINS CONFIDENTIAL INFORMATION PROPRIETARY TO GMW ASSOCIATES. IT MUST NOT BE REPRODUCED OR DISCLOSED TO OTHERS OR USED IN ANY WAY EXCEPT FOR THE INSTALLATION, OPERATION OR MAINTENANCE OF GMW ASSOCIATES PRODUCTS.

CONTENTS

1. SAFETY	1
1.1 SYMBOLS USED IN THIS MANUAL	1
1.2 INSTALLATION, OPERATION, AND SERVICE PRECAUTIONS	2
1.3 LOCKOUT/TAGOUT PROCEDURES	2
2. SPECIFICATIONS	5
2.1 GENERAL SPECIFICATIONS	5
2.2 ELECTRICAL AND WATER CONNECTIONS	6
3. WARNINGS	7
3.1 PERSONNEL SAFETY	7
3.2 FERROMAGNETIC OBJECTS	7
3.3 WATCHES, CREDIT CARDS, AND MAGNETIC MEDIA	7
3.4 ARCING	7
3.5 HOT COIL RESISTANCE	7
3.6 INTERLOCKS	7
3.7 HOT SURFACE	7
3.8 TRIP HAZARD	7
4. INSTALLATION	8
4.1 SITING CONSIDERATIONS	8
4.2 UNPACKING INSTRUCTIONS AND DAMAGE INSPECTION	8
4.3 MAGNET DRAWINGS	8
4.4 MOUNTING	9
4.5 ELECTRICAL CIRCUIT	10
4.6 THE 3474 INTERLOCKS	11
5. OPERATION	13
5.1 GENERAL	13
5.2 POLE GAP ADJUSTMENT	13
5.3 CONVENTIONAL OPERATION	13
5.4 FIELD CONTROL OPERATION	14
6. MAINTENANCE	15
6.1 COOLING CIRCUIT	15
6.2 STRAIN RELIEF	15
6.3 POLE CAP REMOVAL	15
7. OPTIONS & ACCESSORIES	17
7.1 STANDARD POLES	17
7.2 CUSTOM POLE OPTIONS	17
7.3 MAGNETIC FIELD MEASUREMENT	17
7.3.1 PROBES	17
7.3.2 PROBE HOLDERS & MOUNTS	17
7.4 MODULATION & BIASING COILS	17
7.5 MAGNET MOUNTING	17
7.5.1 MOUNTING BRACKETS	17
7.5.2 MOUNTING BASES	17
7.6 POWER SOURCES	18
7.7 MAGNET CONTROL	18
7.8 EQUIPMENT CABINET	18
8. EXITATION CURVES	19
8.1 FIELD VS GAP, 140 AMPS	19
8.2 FIELD VS CURRENT 250MM POLE FACE, 5-160 GAP	20
8.3 FIELD VS CURRENT 200MM POLE FACE, 5-160 GAP	21
8.4 FIELD VS CURRENT 150MM POLE FACE, 5-160 GAP	22
8.5 FIELD VS CURRENT 100MM POLE FACE, 5-100 GAP	23
8.6 FIELD VS CURRENT 75MM POLE FACE, 5-80 GAP	24
8.7 FIELD VS CURRENT 50MM POLE FACE, 5-40 GAP	25
8.8 FIELD VS CURRENT 25MM POLE FACE, 5-80 GAP	26
8.9 MODULATION COIL PLOTS	27
9. FIELD UNIFORMITY PLOTS, STANDARD POLES	33
9.1 FIELD VS POSITION 200MM POLE FACE, 130MM GAP	33

9.2	FIELD VS POSITION 250MM POLE FACE, 10 TO 160MM GAP	35
9.3	FIELD VS POSITION 250MM POLE FACE, 120MM GAP	37
9.4	FIELD VS POSITION 250MM POLE FACE, 50MM GAP	39
9.5	FIELD VS POSITION 250MM POLE FACE, 30MM GAP	41
9.6	FIELD VS POSITION 250MM POLE FACE, 25MM GAP	43
9.7	HIGH UNIFORMITY	44
9.7.1	HIGH UNIFORMITY POLES ASSEMBLY	44
9.8	POLTTING AXIS	45
10.	5 GAUSS SURFACE PLOTS.....	46
11.	OPTIONS AND ACCESSORIES DRAWINGS.....	47
11.1	STANDARD POLES	47
11.1.1	DRAWING 17801710 - 3474 POLE CAPS	47
11.2	CUSTOM POLE OPTIONS.....	48
11.2.1	DRAWING 17207-0734-0 3474 300MM POLE CAP.....	48
11.2.2	DRAWING 12907-2001-0 3474 POLE CAP WITH 4MM HOLE	49
11.2.3	DRAWING 12207-0005-0 100MM POLE CAP WITH MOUNTING HOLES	50
11.3	MAGNETIC FIELD MEASUREMENT	51
11.3.1	DRAWING 19907-0043-0 PROBE MOUNT KIT, HORIZONTAL.....	51
11.3.2	DRAWING 11907-0668-0 PROBE HOLDER TRANSVERSE, SENIS TYPE 'C'	52
11.3.3	DRAWING 11901230 MPT PROBE HOLDER TRANSVERSE	53
11.3.4	DRAWING 11906-0000-0 A MPT PROBE HOLDER ASSY TRANSVERSE MACHINABLE GAROLITE.....	54
11.3.5	DRAWING 11900330 3474 POLE SPACER ASSEMBLY.....	55
11.3.6	DRAWING 11900461 3474 POLE SPACER.....	56
11.3.7	DRAWING 17900691 3474 POLE SPACER ASSEMBLY	57
11.4	MODULATION & BIASING COILS.....	58
11.4.1	DRAWING 11207-0031-0 5494 MODULATION COIL RH	58
11.4.2	DRAWING 11901482 3474 BIAS COIL ASSEMBLY – RH	59
11.4.3	DRAWING 11901481 3474 BIAS COIL ASSEMBLY – LH	60
11.5	MAGNET MOUNTING	61
11.5.1	DRAWING 11900480 45° MOUNTING SEQUENCE.....	61
11.5.2	MOUNTING BRACKETS.....	62
11.5.2.1	DRAWING 17801730 45° MOUNTING BRACKETS	62
11.5.2.2	DRAWING 17802690 VERTICAL MOUNTING BRACKET	63
11.5.3	BASES.....	64
11.5.3.1	DRAWING 11801800 ROLLING BASE ASSEMBLY	64
11.5.3.2	DRAWING 11900990 ROTATING BASE ASSEMBLY.....	65
11.5.3.3	DRAWING 11900980 ROLLING & ROTATING BASE ASSEMBLY.....	66
11.5.3.4	DRAWING 11900490 VERTICAL MOUNTING ASSEMBLY	67
11.5.3.5	DRAWING 11900940 45° MOUNTED ON ROTATING BASE.....	68
11.5.3.6	DRAWING 11900690 45° MOUNTED ON ROLLING BASE	69
11.5.3.7	DRAWING 11900930 45° MOUNTING ON ROLLING & ROTATING BASE	70
11.5.3.8	DRAWING 11900970 HORIZONTAL MOUNTING ON ROTATING BASE	71
11.5.3.9	DRAWING 11900960 HORIZONTAL MOUNTING ON ROLLING BASE	72
11.5.3.10	DRAWING 11900950 HORIZONTAL MOUNTING ON ROLLING & ROTATING BASE.....	73
11.5.3.11	DRAWING 11900801 MOTORIZED ROTATING DRIVE, ROLLING BASE	74
12.	SHIPPING CRATES.....	75
12.1	DRAWING 18800191 SHIPPING CRATE ASSEMBLY	75
13.	MAGNET DRAWINGS	76
13.1	DRAWING 11801602 VARIABLE GAP MAGNET ASSEMBLY	76
13.2	DRAWING 11801603 FIXED GAP MAGNET ASSEMBLY.....	77
13.3	DRAWING 11901360 IN/OUT MANIFOLD ASSEMBLY	78
13.4	DRAWING 19907-0004-0 TOOL KIT	79
14.	WIRING DRAWINGS	80
14.1	DRAWING 11901020 MOTORIZED ROTATING DRIVE ELECTRICAL ASSEMBLY	80
14.2	DRAWING 13900350 MOTORIZED ROTATING DRIVE ELECTRICAL WIRING	81
14.3	DRAWING 1C907-0060-0 ELECTRICAL ASSEMBLY 3474/SGA100-150/5971.....	82
14.4	DRAWING 1D907-0060-0 ELECTRICAL WIRING 3474/SGA100-150/5971	83
14.5	DRAWING 1C907-0061-0 ELECTRICAL ASSEMBLY 3474/SGA100-200/5971.....	84
14.6	DRAWING 1D907-0061-0 ELECTRICAL WIRING 3474/SGA100-200/5971	85

15. WARRANTY and SERVICE	86
16. TECHNICAL REFERENCES	87
16.1 THERMO SCIENTIFIC WATER CHILLERS.....	87
16.2 WATER FILTER BAG KIT.....	87
16.3 THERMO SCIENTIFIC CONTACT INFORMATION.....	87
16.4 THERMO SCIENTIFIC WATER TREATMENT KIT.....	88
16.5 SELCO THERMOSTAT SPECIFICATIONS.....	89
16.6 MODEL 3474 SYSTEM INSTALLATION; NORTH AMERICA.....	90
16.7 MODEL 3474 SYSTEM INSTALLATION; CHECK LIST.....	91

1. SAFETY

1.1 Symbols Used In This Manual



Important information. This label indicates important information that must be read and understood prior to operation.



Warning relating to the presence of magnetic field.



Warning relating to a trip hazard.



Warning relating to hot surfaces.



Warning relating to the potential for electrical shock.



Warning relating to the potential of injury due to lifting heavy weight.



Warning relating to magnetic fields and medical implants and pacemakers.

1.2 Installation, Operation, and Service Precautions



During installation or servicing this magnet must be locked out following the Lockout/Tagout procedure defined in section 1.3.



This product is designed for use in accordance with SOP39. Hazardous voltages are present within this product during normal operation. The product should never be operated with any of the covers removed.



When operated at peak direct current of 140A the surface temperature of the coils of the electromagnet can rise as high as 80°C. Care must be taken not to touch the coils for extended periods.

1.3 Lockout/Tagout Procedures

Purpose:

To protect personnel and ensure that machines and equipment are isolated from potentially hazardous electrical energy. Lockout or tagout must occur before employees perform service, maintenance, or renovation. This is important where unexpected start-up could cause personal injury, fire, or equipment damage.

Policy:

All equipment shall be locked out where possible. Where such control is not possible, equipment may be tagged out-of-service. In all instances, equipment shall be made inoperable to protect against possible operation where such operation may cause personal injury or damage. Employees must not attempt to operate any switch or source of energy which is locked out or tagged out.

Procedures:

1. When working on systems which could accidentally be activated, the system shall be locked out or tagged out by use of a safety lockout device and padlock. In addition, a tag shall be used to identify the purpose of the shutdown, the employee involved, the date the unit was removed from service, and when the system may operate again.
2. If more than one source of energy is present, all such sources must be locked out or tagged out. Special procedures must be followed to ensure that the equipment is disconnected from an energy management system or emergency generator system that may start or energize the equipment.
3. A lockout is required on all systems where possible. A tagout is an acceptable means of protection on systems which are less hazardous. An example of less hazardous is a device, if started accidentally, would not cause personal injury.
4. If more than one person is involved in the repair, each person shall install a lock and or tag

to the equipment energy source. An employee may not use the tag or lock of another employee.

5. After servicing, renovation, or maintenance is complete, the area must be checked for tools, parts, removed guards, and assurance that no personnel are in the danger zone. Then the lockout or tagout will be removed by the same employee who initially locked it out so energy may be restored to the equipment.
6. If the employee who locked out or tagged out the equipment is unavailable, the supervisor may remove the lock or tag if the following conditions are met:
 1. Verification that the employee who applied the device has left for the duration of the shift and is not at the job site.
 2. Made reasonable efforts to reach the employee.
 3. Inform the employee that the lock or tag has been removed and the system is no longer de-energized, before the employee resumes work.
7. Employee's using lockout/tagout devices shall have training about this program, and shall have annual retraining to ensure that the employee understands and follows this program. The training and retraining shall be documented with the training records maintained by the training coordinator.
8. Outside contractors are required to follow this policy or provide a similar policy that is in compliance with Occupational Safety and Health Administration (OSHA) Standard 1910.147. Under no circumstances are outside contractors authorized to remove a lockout/tagout device nor are they allowed to energize a locked out/tagged out system.

Lockout/Tagout Procedures Checklist:

The following steps must be followed in sequence to properly lockout/tagout and re-establish energy:

I. Understand the hazard:

Electrical

Electrical Shock and or burn could result from contact with the exposed conductors line voltage or high voltage equipment. Flying parts or fire could result if this circuit were shorted. Electricity should be controlled at the circuit breaker, main switch, or fuse box.

Mechanical

Equipment or machinery can inflict tissue or skeletal injury through crushing, laceration or impalement. This can be controlled through the main electrical switch, plug, circuit breaker or anti-motion pin.

Thermal

May cause burns or fires. It can be controlled by the main electrical switch, electrical plug control, electrical circuit breaker, electrical fuse box, steam valve, fluid line valve or shielding.

II. Shutdown:

Know what type of energy the machine uses.

Identify its potential hazards.

Find the switches or other devices that control energy and need to be locked out. Let employees know that you will be locking or tagging out the equipment and why. Turn off the machine or equipment.

III. Isolate the source of energy

Electrical

- Locate the main switch box or circuit breaker.
- Open the breaker, open the switch or remove the plug.
- Attach a lockout enabling device if the circuit cannot otherwise accommodate a padlock.
- Place plug in a plug lock box.

Mechanical/Storage Potential Energy

- Lockout enabling device.
- Secure the energy controlling lockout by attaching a personal lock and completed tag to the lockout enabling device. If more than one person will be performing the work, each must apply their own lock to a multiple lock device.
- Release all stored energy.
- If there is a heat exposure, allow to cool.

Release from Lockout/Tagout

1. Inspect the surrounding area following completion of work for loose tools, parts, correct valve settings, system integrity, and exposed conductors.
2. Check that all machine guards are in place and reconnected if applicable.
3. Notify others in the area that the equipment is about to be made operational and returned to service.
4. Remove personal lock, tag, and lockout enabling device. This step must be performed by the same person who applied the tag and lock.

Lockout/Tagout Training

The lockout/tagout program is designed to train employees on disabling powered equipment from their power sources before beginning any servicing or maintenance work. Lockout/tagout training is required for all employees who may possibly need to lockout and tagout equipment.

Employees will receive annual training in the following areas:

1. Recognition of applicable hazardous energy sources.
2. Methods and Means necessary for energy isolation and control.
3. Restrictions and limitations of lockouts.

2. SPECIFICATIONS

2.1 General Specifications

Pole Diameter	250 mm (10 inch)
Pole Gap *	0 - 160 mm (0 to 6.3 inch)
Standard Pole Caps:	250 mm (10 inch) cylindrical
Pole Face Diameter	200 mm (8 inch) tapered 150 mm (6 inch) tapered 100 mm (4 inch) tapered 75 mm (3 inch) tapered 50 mm (2 inch) tapered 25 mm (1 inch) tapered
	series connection
Coil Resistance (20° C)	0.44 ohm
Maximum Resistance (hot)**	0.54 ohm
Maximum Power [air]	40A/22V (0.88kW)
Maximum Power [water]	140A/76V (10.6kW)
Self Inductance	80mH (measured at 5Hz)
Water Cooling (18° C)	15 liters/m (4 US gpm) 2.0 bar (30 psid), max 10 bar (145psid)
Overtemperature Interlock	Selco thermal switch part number OA-150-ST-G mounted on each coil and wired in series. Contact rating 120Vac,0.5A. Closed below 65° C.
Water Flow Interlock	Johnson Controls flow switch part number F61KD mounted on outlet side of water circuit. Contact rating 120Vac/16A, 240Vac/8A non-inductive Set to open at a flow of less than 10 liter/min.
Dimensions	Drawing 11801602/11801603 920mm W x 636 mm D x 864 mm H (36.2 inch W x 25.0 Inch D x 34.0 inch H)
Weight	1800 kg (3970 lb)



CAUTION - The value of maximum coil resistance given should not be exceeded. At this resistance the coils are at maximum safe temperature for continuous operation.

2.2 Electrical and Water Connections

Refer to Drawing [11801602/11801603](#)

DC Current

Right hand terminal Negative

Left Hand terminal Positive

Ground

An M6 screw is provided alongside the dc current connections to enable the magnet frame to be grounded according to local safety regulations. It is normally appropriate to connect the magnet frame to the power supply ground.

Interlocks (Refer to Drawing 11801602/11801603)

- | | |
|--------------------|--|
| 1. Water flow | Normally open. Closed when flow over 16 l/min (2.7 US gpm) |
| 2. Water flow | |
| 3. Overtemperature | Normally closed. Open when coil temperature exceeds 65°C |
| 4. Overtemperature | |
| 5. No connection | Reserved for
Bias/Modulation
Coils |
| 6. No connection | |
| 7. No connection | |
| 8. Control ground | |

Water (Refer to Drawing 11801602/11801603)

outlet 3/8 inch NPT

inlet 3/8 inch NTP

(mating couplings for 1/2 inch hose provided)

CAUTION - Ensure that the high current connections are tight. Loose connections may lead to oxidation and overheating. The field stability may be degraded and the current terminations damaged.

3. WARNINGS

Read and understand the manual before attempting to operate the 3474 electromagnet. Read and understand the warnings posted on the electromagnet and in this manual.

Failure to comply with all of these warnings may cause serious injury.

3.1 Personnel Safety



The Model 3474 has a low level of fringe field. In operation the magnet fringing field can be in excess of 0.5mT (5G). This can cause malfunctioning of heart pacemakers and other medical implants. We recommend that the fringing field should be mapped and warning signs be placed outside the 0.5mT (5G) contour. Entry to this region of higher field should be restricted to qualified personnel. Refer to [section 10](#) for 3474 Electromagnet 0.5mT (G) Plots.

3.2 Ferromagnetic Objects



During operation the magnet exerts strong magnetic attraction towards ferromagnetic objects in the near vicinity. Loose objects can be accelerated to sufficient velocity to cause severe personnel injury or damage to the coils. Keep ferromagnetic tools clear.

3.3 Watches, Credit Cards, and Magnetic Media



Do not move magnetically sensitive items into the close vicinity of the magnet. Even some anti-magnetic watches can be damaged when placed in close proximity to the magnet during operation. Credit cards and magnetic disks are affected by magnetic fields as low as 0.5mT (5G).

3.4 Arcing



This magnet stores considerable energy in its field during operation. Do not disconnect any current lead while under load or the magnetic field energy will be discharged across the interruption causing hazardous arcing.

3.5 Hot Coil Resistance



Do not exceed the maximum coil hot resistance given in the specifications or coil overheating and possible damage may occur.

3.6 Interlocks



These should always be connected if the magnet is to be operated unattended, to avoid the possibility of coil overheating caused by excessive power dissipation or inadequate cooling.

3.7 Hot Surface



These should always be connected if the magnet is to be operated unattended, to avoid the possibility of coil overheating caused by excessive power dissipation or inadequate cooling.

3.8 Trip Hazard



Caution must be taken when moving around the magnet as there are potentially cables on the floor that will present a trip hazard. It is highly advised that floor conduit be purchased that will cover the cables. This will also protect the cables from potential damage.

4. INSTALLATION



Caution: This is a heavy system. The magnet mass is approximately 1800 kg (4000 lb) so lifting equipment of this capacity should be used to shift the magnet. Two lifting eyes threaded M33 are provided and they can be used in several holes. Be sure to ensure the eyes are screwed fully home before use. Flexible lifting slings of at least 4000kg (9,000 lb) lifting capacity are recommended to avoid damage to the magnet. All movement, lifting and installation of the 3474 Electromagnet must be under the supervision of an experienced person to prevent the possibility of serious injury or damage to the Electromagnet and associated equipment.

For facility requirements specific for systems installed in North America see [section 16.3](#)

4.1 Siting Considerations



The Model 3474 is not magnetically shielded. Ferro-magnetic material in the vicinity of the magnet will modify the magnitude and uniformity of the central region magnetic field. As a general rule avoid magnetic material closer than approximately one meter of the central region.

Background fields such as the geomagnetic field and alternating field from 60Hz power sources are not shielded by the magnet and will add to the field produced by the magnet. If possible, these background fields should be measured and their effects evaluated before the Model 3474 magnet is installed. It may be necessary to orient the magnet axis to minimize the effects of external fields, to relocate ac power sources or to install suitable magnetic shielding.

4.2 Unpacking Instructions and Damage Inspection

To unpack the electromagnet please use the following procedure (Refer to [Drawing 18800191](#)).

1. First remove all of the "Hex Head Screws" located at the lower edge of all the side panels of the "Crate Top Cover".
2. Gently rock the "Crate Top Cover" to work it loose from the shipping crate base.
3. Use one person on each side of the shipping crate grip the side panels of the Crate Top Cover. Lift "Crate Top Cover" high enough to clear top of electromagnet, walk cover sideways to clear area and place on floor.
4. Inspect the magnet to ensure that no damage has occurred to the magnet in shipment. If damage is evident report the damage in detail to the shipper for claim and simultaneously notify GMW in case assessment of the damage must be made. If no damage is found proceed with magnet unpacking and installation.
5. Remove the M16 Hex Bolts that secure the magnet to the steel shipping angle brackets.
6. Remove the hex lag bolts that secure the steel "shipping angle brackets" to shipping crate base, and remove shipping angle brackets.
7. Install M33 lifting eye and washer to top of magnet yoke, screw down firmly.
8. The magnet is now prepared for final installation, follow the appropriate following procedure to install to 45°, vertical or direct mounting.

4.3 Magnet Drawings

[see section 13](#)

4.4 Mounting

Mounting Position

The magnet can be operated in any position. 45 degree mounting angles are available to allow the field axis to be horizontal with the yoke inclined back at 45° for access from the horizontal and vertical direction.

Alternatively, vertical and mounting brackets can be used to position the field axis vertically. In each case the magnet should be oriented with the water lines below the electrical connections to reduce the chance of water leakage shorting electrical connections.

Refer to Mounting Bracket drawings [section 11.5.2](#)

Direct Mounting

1. With suitable lifting equipment (e.g. 4000kg (9000 lb.) minimum safe lifting rating), lift magnet 50mm (2") clear of shipping crate base.
2. Slide shipping crate base clear.
3. Lower magnet to 50mm (2") above floor.
4. Move magnet to final location and secure using the steel shipping angle brackets. The brackets can be modified to suit installation space needs.

45° Mounting Sequence (Refer to Drw [11900480](#))

1. With suitable lifting equipment (e.g. 4000kg (9000 lb.) minimum safe lifting rating), lift magnet 50mm (2") clear of shipping crate base.
1. Slide shipping crate base clear.
2. Lower magnet to 50mm (2") above floor.
3. Move magnet to desired final location and place on 12mm (0.5") plywood sheet and wooden 100mm x 100mm (4" x 4") blocks (refer to figure 2).
4. Install 45° Mounting Brackets, [drawing 17801730](#), using M16 x 30 Hex bolts, flat and spring washers (refer to figure 2, drw 11900480)
5. Lift magnet from top lifting eye about 50mm (2") remove 100mm x 100mm (4") wooden block located next to 45° mounting bracket (refer to figure 2, drw 11900480).
6. Lower magnet so that it rests only on the front 100mm x 100mm (4") wooden block (refer to figure 3, drw 11900480).
7. Install shackles and lifting sling to BOTH FRONT EYEBOLTS. Caution, keep hands and feet clear of magnet and 45° brackets during the following operation. Take weight of magnet and push the top front of the magnet rearward. The magnet weight should move over center. Lower magnet so that it rests on the 45° mounts (refer to figure 3 and 4, drw 11900480).

Rolling or Rotating or Rolling Rotating Base Mounting (refer to Drw [11900480](#))

Caution do not attempt to move magnet and rotating base or rolling base or rolling rotating base until the magnet has been firmly bolted down to the base (refer to figure 6, drw 11900480).

1. To mount on rolling base or rotating base or rolling rotating base lift magnet from BOTH FRONT EYEBOLTS high enough to clear top of base (refer to figure 5).
2. Slide rolling base or rolling rotating base underneath, lower magnet to 12mm (0.5") above base top surface (refer to figure 5).
3. Position rolling base or rolling rotating base so the tapped holes in the base are aligned with the 45° mounting bracket hole (refer to figure 5).
4. Lower magnet onto rolling base or rolling rotating base assembly (refer to figure 5).
5. Secure magnet and 45° mounting assembly to rolling base or rolling rotating base with M16 x 25mm long Hex Head Bolts (refer to figure 6).
6. Move magnet base to desired location.
7. Screw down the four support legs located on each corner of the base until the wheels clear the floor by 6mm (.25").
8. Secure the support legs with the locknut.
9. Secure rolling rotating base to an adequate concrete floor to prevent movement and possible injury to personnel during an earthquake.

Pole Cap Selection and Installation (Refer to Drawing [11801602/11801603](#))

Using the field uniformity and induction curves, determine the most desirable pole cap; cylindrical or tapered. In general:

If a uniform field is required use a cylindrical cap.

If a high field is required use a tapered cap.

The pole caps are machined from low carbon steel. This material is relatively soft and easily damaged. Since the pole caps are heavy and awkward to manipulate it is advisable to cover the pole faces to protect them from damage.

For details on how to replace a Pole Cap, go to [Section 6.3](#)

4.5 Electrical Circuit

Never connect or remove cables from the magnet with the power supply connected. The stored energy in the magnet can cause arcing resulting in severe injury or equipment damage.

The magnet has two coils which may be connected in series (140A/76V) Model: 3474-140 or in series/parallel (280A/38V) Model: 3474-280 to match different power supplies. Refer to [drawing 11801602/11801603](#). The power supply cables should be connected directly to the DC current terminals marked + and -. Recommended current cable is stranded copper of 120mm² cross section (250MCM) for the 280A/38V coil connections. For 140A/76V coil connections use 70mm² cross section (2/0 AWG) standard copper current cables.

Because the magnet stores a significant amount of energy in its magnetic field, special care should be taken to ensure that the current terminations are secure and cannot work loose in operation. Local heating at the terminations can cause rapid oxidation leading to a high contact resistance and high power dissipation at the terminals. If left unattended this can cause enough local heating to damage the terminals and the coils.

4.6 The 3474 Interlocks

The Model 3474 is fitted with six thermostats, [Selco Part No. QA-150-ST-G](#). Three thermostats are fitted to each coil, underneath the terminal cover. They are wired in series and terminated in positions 3 and 4 on the Interlock Terminal block. The thermostats are normally closed, opening when the coil temperature exceeds 65°C, ± 5°C. The flow switch is connected to terminals 1 and 2. The contacts are normally open, closing when the water flow exceeds approx. 10 L/min.

In the event of any one of these interlocks opening, the power is cut from the power supply and the system is de-energized. The temperature switches will automatically reset once the proper operating conditions have been met. This may take some time, even when the magnet temperature falls below 65°C



In the event of an interlock tripping it is strongly recommended that the root cause of the trip be determined. In the event that the root cause cannot be determined please contact GMW Associates for technical support.

Interlock Testing



It is crucial that before general operation of the magnet system, that the interlock circuits be tested. This test requires that the terminal cover be removed from the magnet while energized and therefore must be completed by a qualified electrician.



This test should be done with the magnet operating with a LOW power setting, preferably less than 5 amps.

DO NOT AT ANY POINT TOUCH OR DISCONNECT THE MAGNET DC POWER CABLES.

Thermal Switches: Carefully remove one of the temperature switch connections from the interlock termination block. The power supply output MUST enter a disabled state. Reconnect the connection and the power supply output should return to normal.

This interlock testing procedure should be carried out no less than every six months.

Cooling

The Model 3474 can be operated to an average coil temperature of 70°C. Assuming an ambient laboratory temperature of 20°C, the hot resistance of the coil should not exceed 20% more than the ambient temperature "cold" resistance.

The coil thermal sensor will open when the coil cooling plate temperature exceeds approximately 65°C. Clean, cool (12°C – 20°C) water at 15 L/min and 2.0 bar (30 psid) should be used to cool the magnet. The cooling tubes are not electrically connected to the coils so no electrochemical corrosion will occur. If the water supply contains particulates, a 50-micron filter should be placed before the input to the magnet to avoid unreliable operation of the flow switch.

For continuous operation of the magnet it may be appropriate to use a recirculating chiller to reduce water and drainage costs. The chiller capacity will depend on whether cooling is required for the magnet alone or magnet and power supply. For the Model 3474 Electromagnet alone, a

suitable chiller is the ThermoFisher TSC2100 with C1 pump. Use distilled or deionized water with a biocide to prevent bacterial growth and corrosion. Do not use corrosion inhibitors in high quality electrical systems since the water conductivity is increased which can result in increased leakage currents and electrochemical corrosion.

At currents of below 40A for coils that are series connected or 80A for series/parallel connected coils the Model 3474 can be operated safely without water cooling. However, the coil temperature will vary with the power dissipation. This results in dimensional and permeability changes of the magnet yoke. Air cooling is not suitable when high field stability is required.

Freon, oil, ethylene glycol or other cooling mediums can be used. The flow required will be approximately inversely proportional to their specific heats. An experimental determination of the flow and pressure required will be necessary.

Avoid cooling the magnet below the dew point of the ambient air. Condensation may cause electrical shorts and corrosion.

During operation the resistance can be checked using a voltmeter across each coil. The voltage will rise to a constant value once thermal equilibrium has been reached. If it is desired to save water, the flow can be reduced until the hot resistance is approached. NOTE: This adjustment must be made slowly enough to allow for the thermal inertia of the coils.

5. OPERATION

5.1 General

The 3474 operates as a conventional electromagnet.



The 3474 electromagnet is water cooled and should not be operated to full power without water. If using air cooling, care must be taken to avoid damage to the magnet. Please refer to the specification in [section 2](#) referring to air cooling for guidelines.



This product is an electromagnet and creates significant magnetic fields both within the magnet and in the surrounding area. Make sure that there are no ferromagnetic items, tools or components loose in a 1 meter radius surrounding the magnet.



The Model 3474 is not a shielded electromagnet. In operation the magnet fringing field can be in excess of 0.5mT (5G). This can cause malfunctioning of heart pacemakers and other medical implants. We recommend that the fringing field should be mapped and warning signs be placed outside the 0.5mT (5G) contour. Entry to this region of higher field should be restricted to qualified personnel. Refer to [section 10](#) for 3474 Electromagnet 0.5mT (G) Plots.



Do not move magnetically sensitive items into the close vicinity of the magnet. Even some anti-magnetic watches can be damaged when placed in close proximity to the magnet during operation. Credit cards, and magnetic disks are affected by magnetic fields as low as 0.5mT (5G).

5.2 Pole Gap Adjustment

NOTE: Prior to adjusting pole gap, de-energize the electromagnet first. Failure to do so may result in damage to equipment and personal injury.

5.3 Conventional Operation

1. Adjust the poles to the desired gap with the poles approximately symmetrical about the center magnet. To reduce mechanical backlash when the magnetic field is applied, it is best to set the poles by increasing the gap.
2. Adjust the cooling water flow to approximately 15 liters / minute (4 US gpm).
3. Turn on the power supply and increase the current until the desired field is reached. Note that constant current operation is preferred for stable field performance. Please refer to the user manual of the selected power supply.

5.4 Field Control Operation

The necessity to use calibration curves can be avoided by using a field controller to sense the magnetic field and provide a corresponding power supply control signal through the power supply programming inputs. Contact GMW (sales@gmw.com) for suitable instrumentation and LabVIEW software.

Calibration

The induction curves may be used to estimate the field in the air gap to within four or five percent. More accurate field determination may be obtained by deriving experimentally a calibration curve for the particular pole and air gap combination being used. Magnetic hysteresis in the yoke and poles can cause an error of 30 to 70G (3 to 7mT) with an arbitrary application of such a calibration curve. This effect may be reduced to less than one percent by following a prescribed 'current setting schedule' designed to make the magnet 'forget' its prior magnetic history. The schedule should of course be used both in establishing the calibration curve and in its subsequent use. A possible schedule would be:

From zero current, increase to maximum current and reduce again to zero current. Increase again to maximum current and reduce to the current to give the desired field setting. Approaching the desired field from a higher setting will typically produce better field uniformity. This is because the field changes at the pole edges will normally lag the field change at the center thereby helping to compensate the radial decrease in field.

Greater precision in setting up the calibration curve will be achieved with the use of a digital gaussmeter and by making a numerical table. This table used with an interpolation routine will eliminate the error associated with reading a graph.

In any event, three points need to be remembered:

1. A calibration curve or table is only as good as the precision employed in generating it.
2. The field is defined only at the point it is measured. It will generally be different at a different point in the air gap. For example, the induction curves refer to the field on the pole axis and at the center of the air gap (median plane).
3. The field is most directly a function of the current in the magnet coils. Voltage across the coils is not a good measure of field since the electrical resistance of the coils depends on the temperature (about 0.4% per degree Celsius).

6. MAINTENANCE



Whenever performing maintenance on this magnet all electrical plug socket disconnects must be disconnected and a plug lockout device used to properly shut down the electrical system. Refer to Lockout/Tagout procedure defined in [section 1.3](#).

Periodically check that the pole adjustment mechanism is clean, properly lubricated and free of grit and dirt, which may cause binding of the mechanism. Be very careful not to damage the relatively soft pole surface since this may degrade the magnetic field uniformity in the gap.

Note that the surface treatments used provide good corrosion protection but in order to maintain the inherent mechanical precision of the magnet, heavy build-up of plating materials is deliberately avoided. As a result, high humidity or otherwise seriously corrosive atmospheres can cause corrosion. Periodically apply an appropriate corrosion protection, particularly when the magnet is stored for an extended period.

6.1 Cooling Circuit

Check the cooling water circuit to ensure the water is clean and free of debris and bacterial growth. If an in-line water filter is used, ensure that the filter is clean. If this magnet is used in conjunction with a closed cycle chiller please refer to the chillers' User Manual for details specific to that chiller for cleaning and maintenance.

6.2 Strain Relief

During the scheduled maintenance it is recommended that cables at the exit from the terminal cover be inspected for tight connection and absence of corrosion. In particular the strain relief should be checked to confirm that the cables are properly restrained from movement. The Lockout/Tagout procedure from [section 1.3](#) should be followed during this procedure.



When inspecting cables to the magnet, the magnet should be de-energized to zero amps and the power supply switched off.

6.3 Pole Cap Removal

Pole cap removal using lifting eye bolt. (Refer to [drawing 11801602/11801603](#))

1. Turn off the power supply
2. Draw pole caps about 20mm into the pole sleeves, so the tapped M10 holes on the pole cap are still clear.
3. Fit the pole cap lifting eye bolt firmly into the top tapped hole (M10) of the pole cap to be removed.
4. Draw in the pole cap that is not to be removed until it is flush with the pole sleeve.
5. Tape cardboard or something similar to the face of the pole cap that is not to be removed to protect it from damage.
6. Support the pole cap weight (approx. weight 38kg/84lbs).
7. Remove the axial retaining stud nut (item 33 on drawing 11801602/11801603).
8. Place the pole cap retaining stud wrench (item 3 on [drw 19907-0004-0](#)) onto the end of the retaining stud (item 6 on drawing 11801602/11801603).

9. Remove retaining stud (item 6 on drawing 11801602/11801603) while supporting the pole cap.
10. **Carefully** rock the pole cap to break the adhesion to the pole and remove from the magnet

If lifting equipment is not available, the pole cap can be removed using the pole cap removal tool, using the following procedure.

Pole cap removal using pole cap removal tool. (Refer to [drawing 11801602/11801603](#))

1. Turn off the power supply
2. Draw pole caps about 20mm into the pole sleeves, so the tapped M10 holes on the pole cap are still clear.
3. Fit the pole cap removal tools (item 3 [drw 19907-0-004-0](#)) firmly into two opposite tapped holes (M10) on the pole cap to be removed.
4. Tape cardboard or something similar to the face of the other pole cap to protect it from damage.
5. Loosen the axial retaining stud nut 1 turn, but do not remove. (item 33 on drawing 11801602/11801603).
6. Use two people to support the weight of the pole cap (approx. weight 38kg/84lbs).
7. Place the pole cap retaining stud wrench (item 5 on drawing 19907-0-004-0) onto the end of the retaining stud (item 6 on drawing 11801602/11801603).
8. Remove retaining stud (item 6 on drawing 11801602/11801603) while supporting the pole cap.
9. **Carefully** rock the pole cap to break the adhesion to the pole and remove from the magnet

Pole cap fitting.

1. Ensure the pole caps and pole cores are clean and free from debris.
2. Reverse the above pole cap removal sequence.

7. OPTIONS & ACCESSORIES

GMW offers several options and accessories to enhance the functionality and performance of the 3474 Electromagnet. Please direct inquiries to sales@gmw.com

7.1 Standard Poles

The 3474 electromagnet is supplied with a pole pair with pole faces of Ø250mm, Ø200mm, Ø150mm, Ø100mm, Ø75mm, Ø50mm or Ø25mm as standard. See [section 11.1](#) for drawings.

7.2 Custom Pole Options

The model 3474 electromagnet can have customized performance by means of switching out the standard pole with a customized pole. GMW Associates will work with customers to provide the magnetic design of custom poles and will also manufacture such poles. Examples of custom pole caps can be found at [section 11.2](#).

Axial Holes - Any of our standard poles may be ordered with axial holes in one or both poles for optical access. Consideration should be made to the effect of field uniformity and field strength. As a general guideline, the hole should not be greater than 1/6th the diameter and not more than 1/3rd that of the pole gap. These poles are made to order. Go to [section 11.2.2](#) for an example drawing.

High Uniformity - GMW are now offering a 'High Uniformity' pole assembly for experiments that require vastly improved field uniformity. Each pole set is custom designed to the user's specific application requirements. They are not suitable for use as a general purpose pole set.

7.3 Magnetic Field Measurement

7.3.1 Probes

GMW supplies SENIS Teslameters and Gaussmeters. SENIS are known for creating high-precision 3D magnetic field transducers, Hall probes, and instruments used in both industrial and laboratory settings.

7.3.2 Probe Holders & Mounts

GMW offers probe mounts and probe holders for horizontal and vertical field orientations. Go to [section 11.3](#) for drawings.

7.4 Modulation & Biasing Coils

The 3474 Series electromagnets can also have customized performance by means of adding Modulation or Biasing Coils. Go to [section 11.4](#) for drawings.

7.5 Magnet Mounting

7.5.1 Mounting Brackets

For users requiring an oriented field, we offer Vertical, Horizontal and 45° Mounting Brackets. Go to [section 11.5.2](#) for drawings.

7.5.2 Mounting Bases

A variety of bases are available for 3474 magnets. Including rolling or rotating bases or a rolling & rotating base. A motorized rotating base is also available. Go to [section 11.5.3](#) for drawings.

7.6 Power sources

GMW work closely with power source manufacturers to offer a wide variety of unipolar and bipolar power supplies that can be customized for specific user applications.

7.7 Magnet Control

The GMW 5972 Magnet Control system acts as controller, interlock and DAQ for GMW Electromagnet Systems. A complete system typically consists of a DC magnet power supply, the 5972 Magnet Control, a SENIS Magnetic Field Transducer, a GMW electromagnet, and computer with control software. For an overview and specifications [click here](#).

7.8 Equipment cabinet

GMW 19" Rack Cabinet. [Click here](#) for details.

8. EXITATION CURVES

8.1 Field vs Gap, 140 Amps

Contract No:

Page: 1 of 1

Date: Oct 26, 2004

Customer:

Engr: G. Douglas

Model: 3474

Power Supply:

Set Current: 140 Amps

Pole Face: As per table below

Position X=0, Y=0, Z=0

Serial No: None

Notes: Data taken in Magneto simulation software

Pole Gap: As per table below

Pole Spacers: None

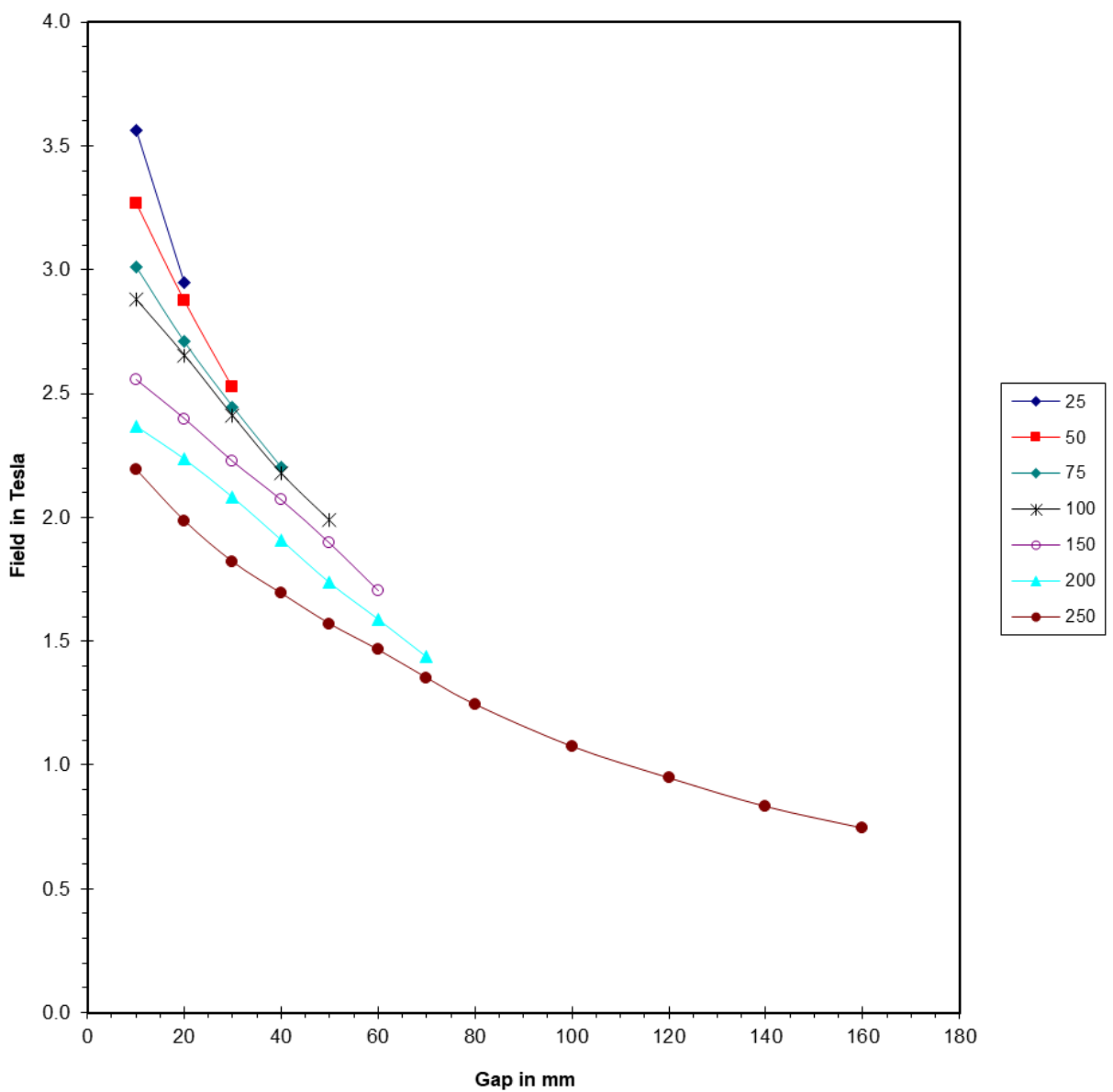

Filename: 3474 Gap-Field

8.2 Field vs Current 250mm Pole Face, 5-160 Gap

Contract No:

Page: 1 of 7

Date: Sept 28, 2004

Customer:

Engr: G. Douglas

Model: 3474

Power Supply:

Set Current:

Serial No: None

Serial No:

Target Field:

Pole Face: 250mm

Position X=0, Y=0, Z=0

Serial No: None

Notes: Data taken in Magneto simulation software

Pole Gap: 05 to 160mm

Pole Spacers: None

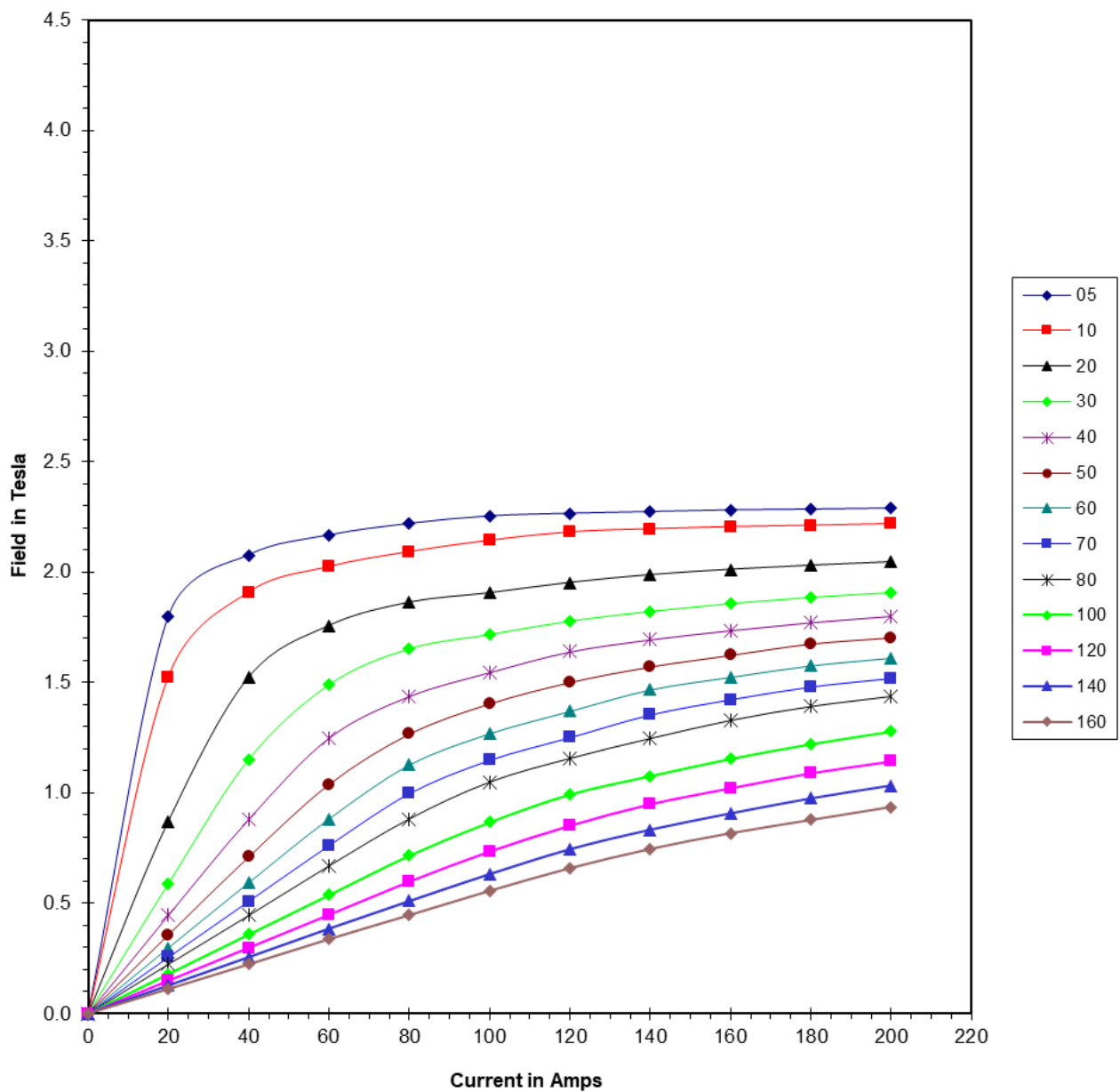

Filename: 3474-250pf_05-160gap_0-200A_Ex1

8.3 Field vs Current 200mm Pole Face, 5-160 Gap

Contract No:

Page: 2 of 7

Date: Sept 28, 2004

Customer:

Engr: G. Douglas

Model: 3474

Power Supply:

Set Current:

Serial No: None

Serial No:

Target Field:

Pole Face: 200mm

Position X=0, Y=0, Z=0

Serial No: None

Notes: Data taken in Magneto simulation software

Pole Gap: 05 to 160mm

Pole Spacers: None

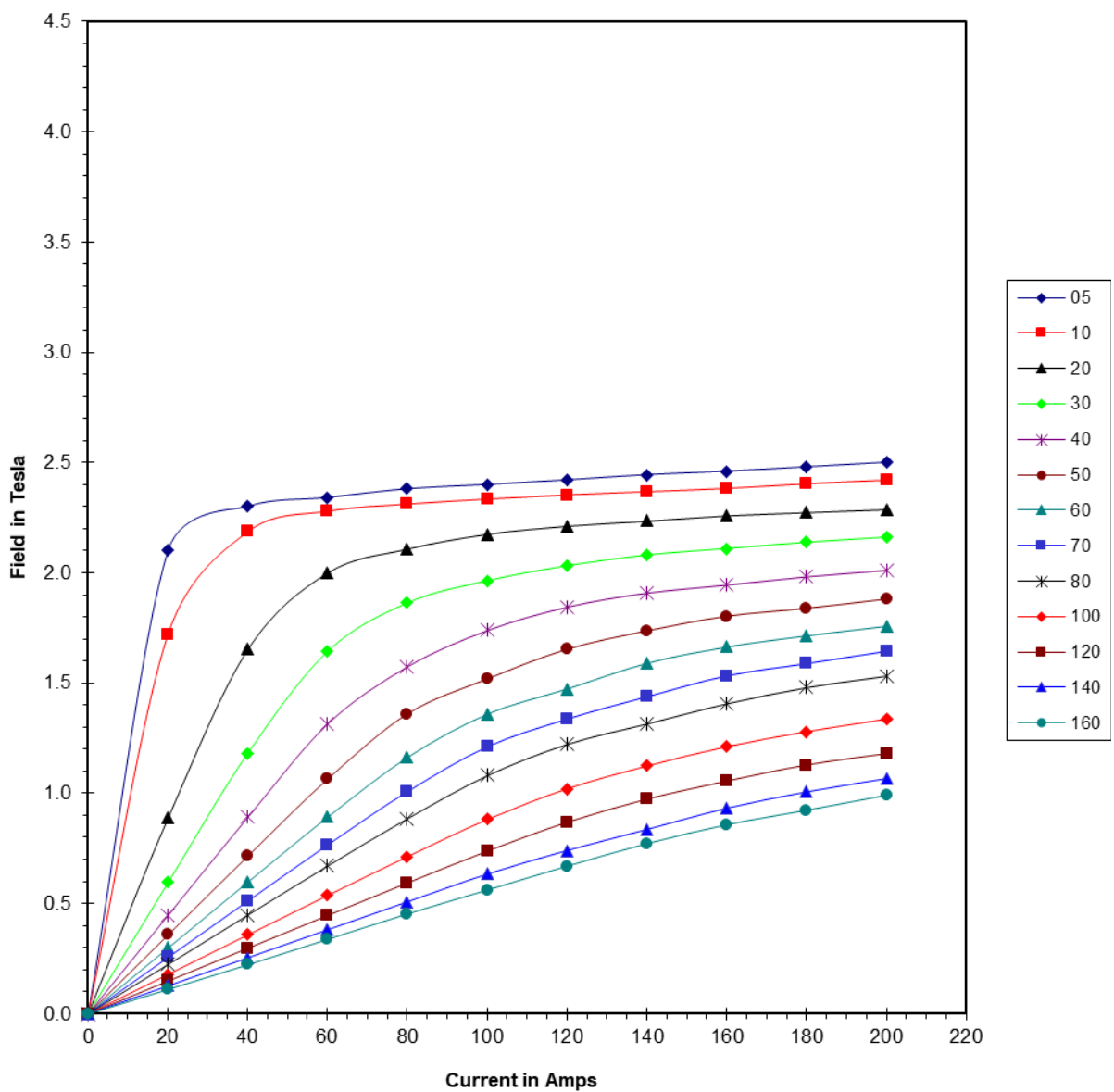

Filename: 3474-200pf_05-160gap_0-200A_Ex1

8.4 Field vs Current 150mm Pole Face, 5-160 Gap

Contract No:

Page: 3 of 7

Date: Sept 28, 2004

Customer:

Engr: G. Douglas

Model: 3474

Power Supply:

Set Current:

Serial No: None

Serial No:

Target Field:

Pole Face: 150mm

Position X=0, Y=0, Z=0

Serial No: None

Notes: Data taken in Magneto simulation software

Pole Gap: 05 to 160mm

Pole Spacers: None

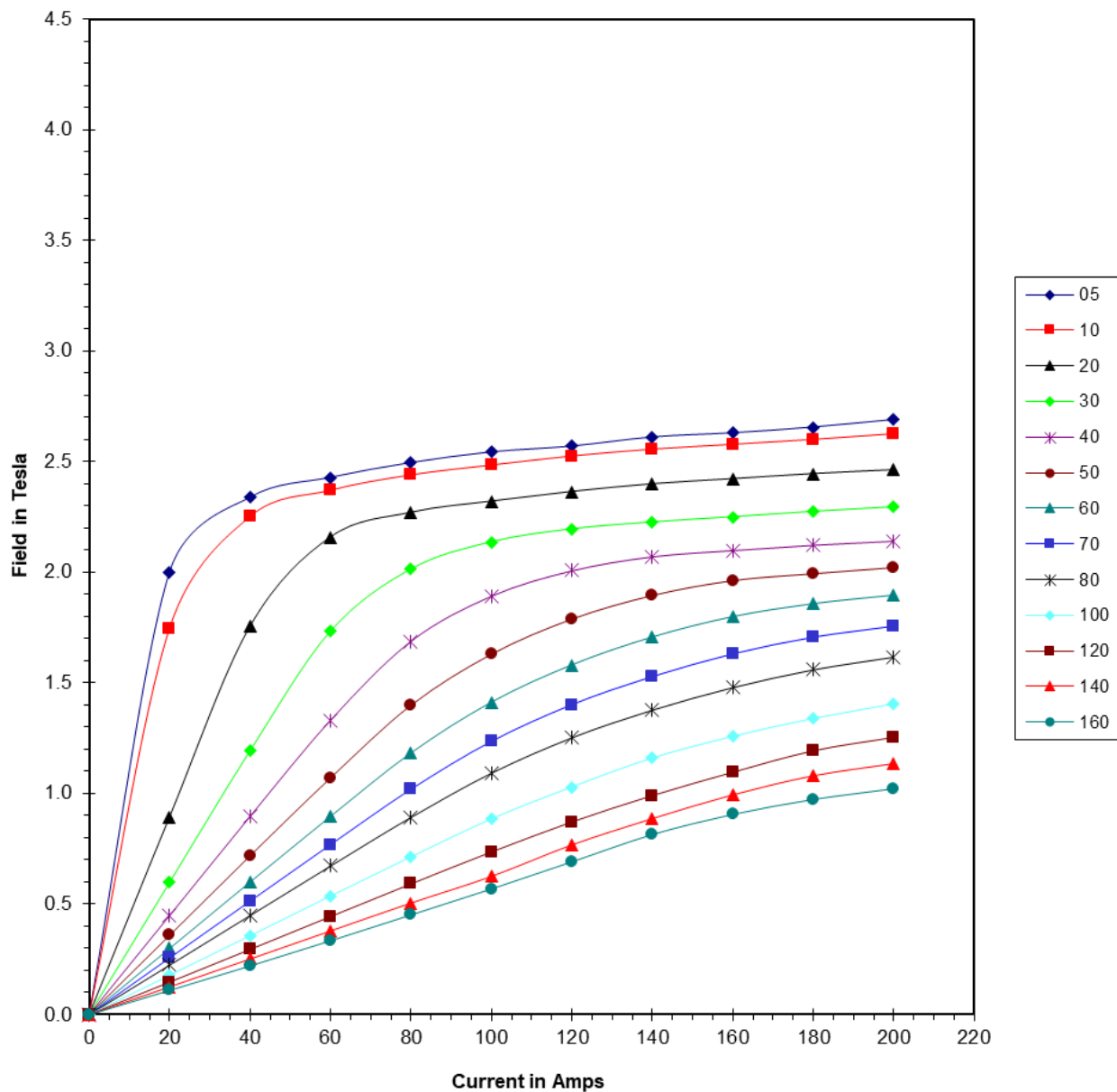

Filename: 3474-150pf_05-160gap_0-200A_Ex1

8.5 Field vs Current 100mm Pole Face, 5-100 Gap

Contract No:

Page: 4 of 7

Date: Sept 28, 2004

Customer:

Engr: G. Douglas

Model: 3474

Power Supply:

Set Current:

Serial No: None

Serial No:

Target Field:

Pole Face: 100mm

Position X=0, Y=0, Z=0

Serial No: None

Notes: Data taken in Magneto simulation software

Pole Gap: 05 to 100mm

Pole Spacers: None

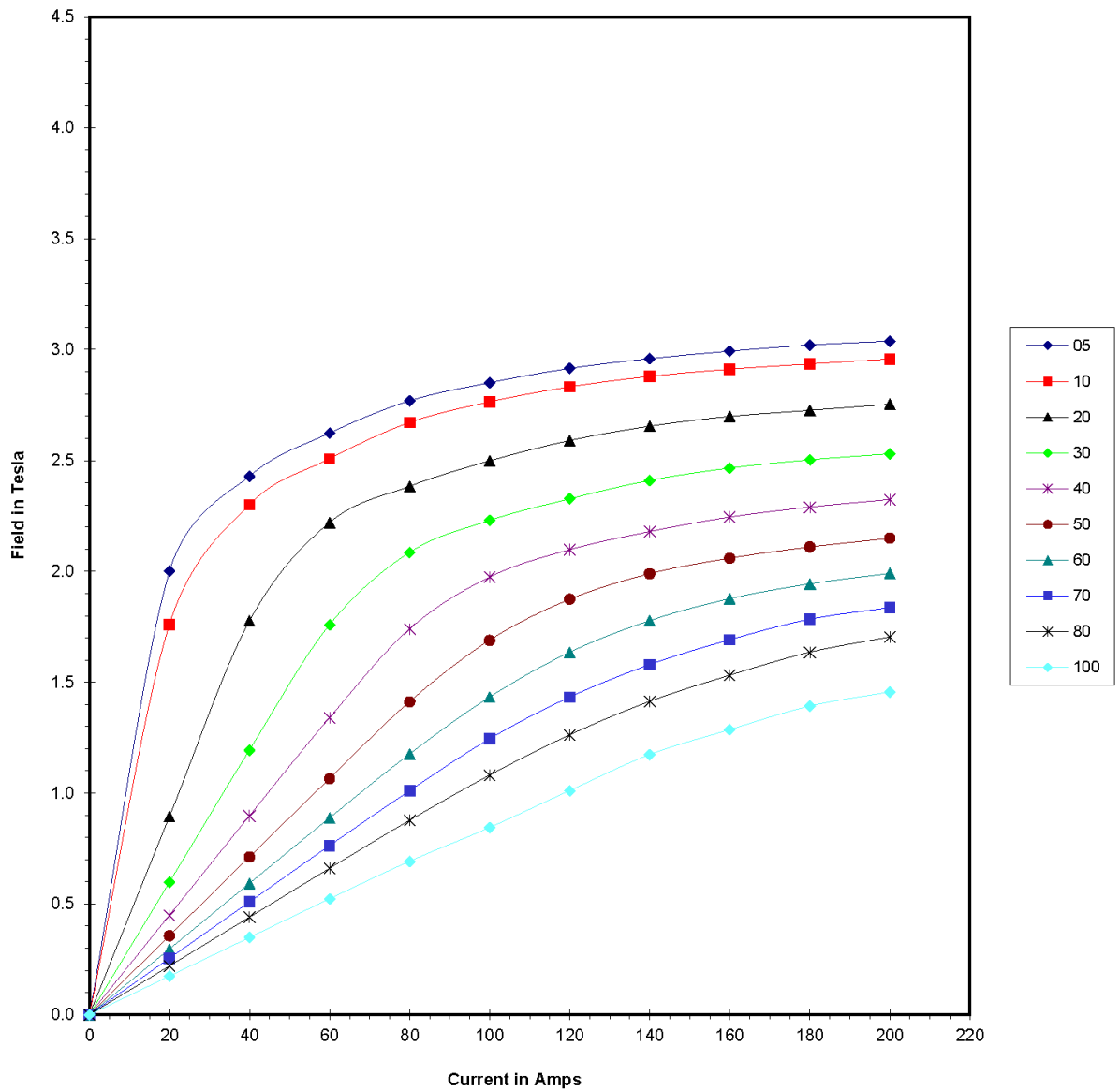

Filename: 3474-100pf_05-100gap_0-200A_Ex1

8.6 Field vs Current 75mm Pole Face, 5-80 Gap

Contract No:

Page: 5 of 7

Date: Sept 28, 2004

Customer:

Engr: G. Douglas

Model: 3474

Power Supply:

Set Current:

Serial No: None

Serial No:

Target Field:

Pole Face: 75mm

Position X=0, Y=0, Z=0

Serial No: None

Notes: Data taken in Magneto simulation software

Pole Gap: 05 to 80mm

Pole Spacers: None

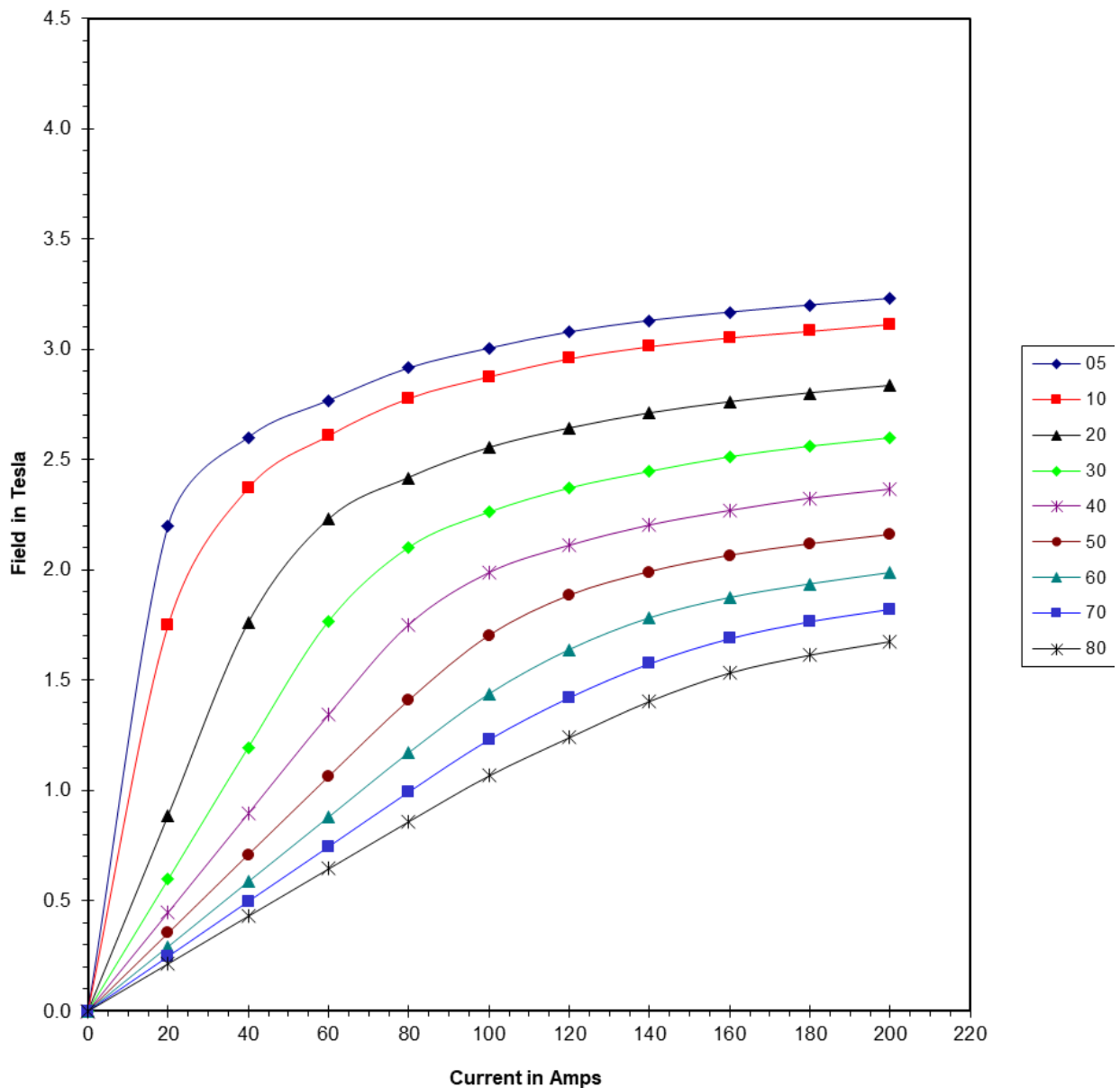

Filename: 3474-75pf_05-80gap_0-200A_Ex1

8.7 Field vs Current 50mm Pole Face, 5-40 Gap

Contract No:

Page: 6 of 7

Date: Sept 28, 2004

Customer:

Engr: G. Douglas

Model: 3474

Power Supply:

Set Current:

Serial No: None

Serial No:

Target Field:

Pole Face: 50mm

Position X=0, Y=0, Z=0

Serial No: None

Notes: Data taken in Magneto simulation software

Pole Gap: 05 to 40mm

Pole Spacers: None

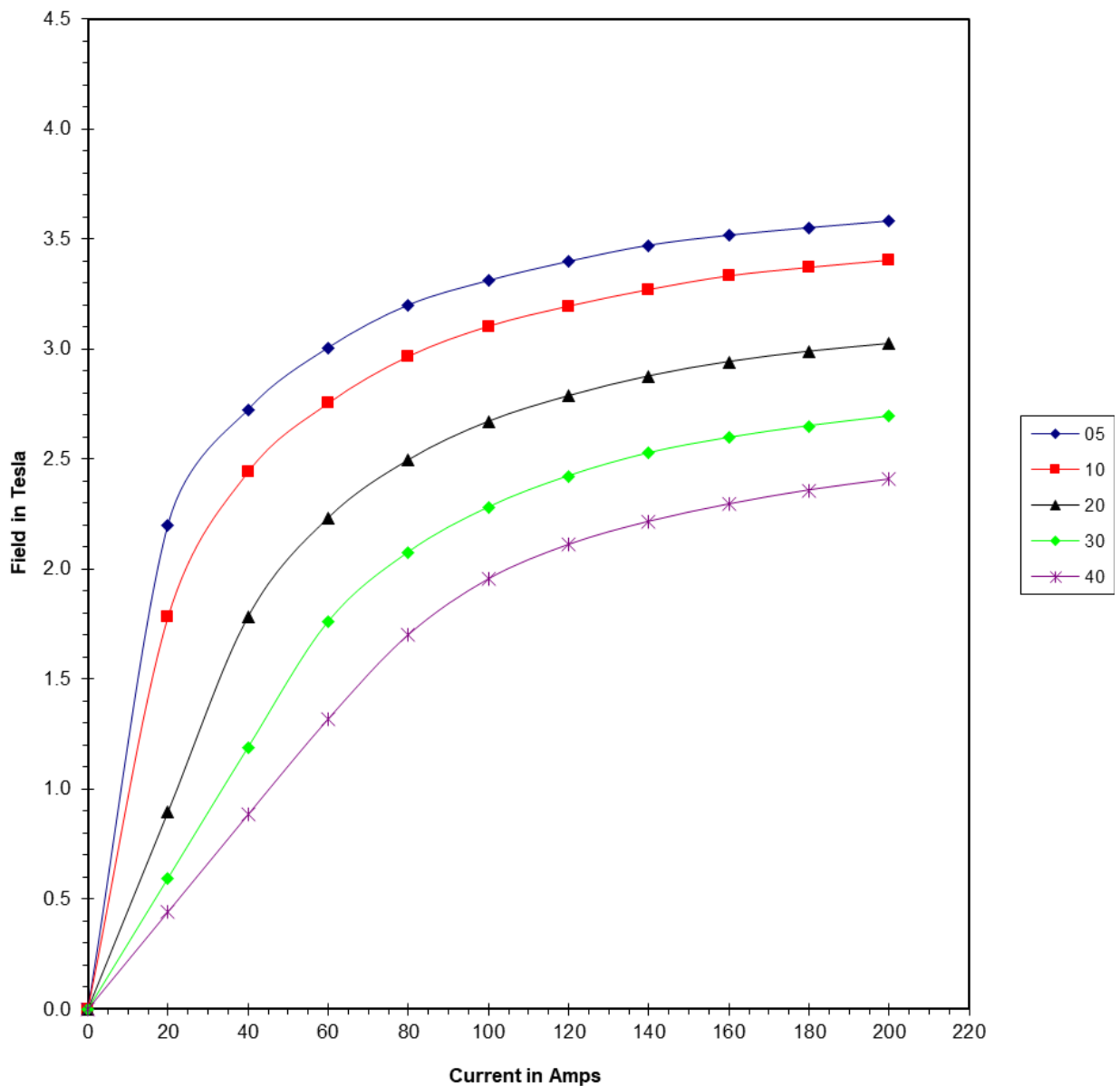

Filename: 3474-50pf_05-40gap_0-200A_Ex1

8.8 Field vs Current 25mm Pole Face, 5-80 Gap

Contract No:
Engr: G. Douglas

Page: 7 of 7

Date: Sept 28, 2004 Customer:

Model: 3474

Power Supply:

Set Current:

Pole Face: 25mm

Position X=0, Y=0, Z=0

Serial No: None

Notes: Data taken in Magneto simulation software

Pole Gap: 5 to 30mm

Pole Spacers: None

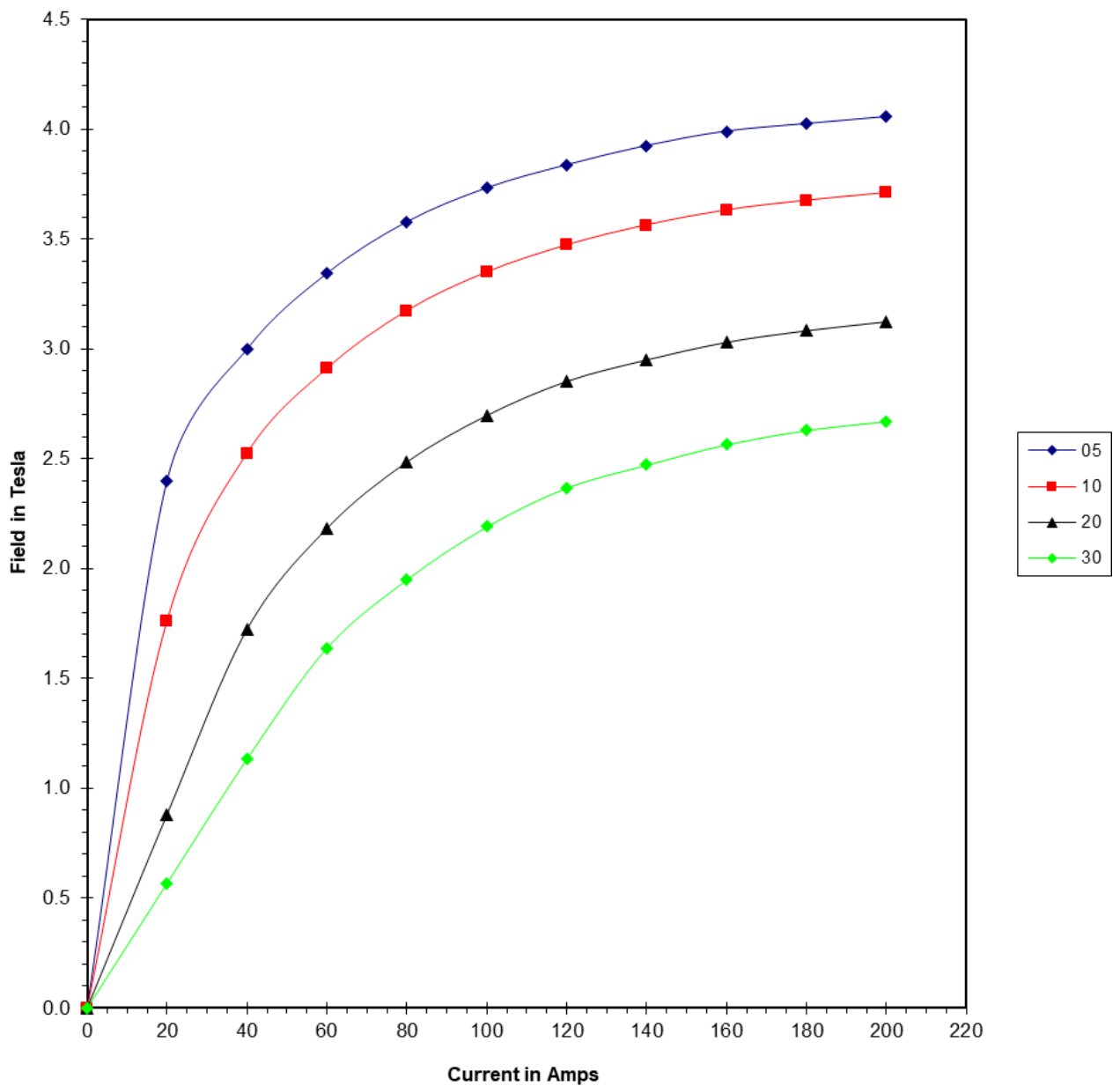

Filename: 3474-25pf_05-80gap_0-200A

8.9 Modulation Coil Plots

GMW Associates

Electromagnet Excitation Plot

Contract No: _____ Page: 1 of 6 Test Date: 6/12/2018
 Customer: _____ Engr: Y.Qin

Magnet 3474-140 Main Power supply: PowerTen 10V/150A
 Pole face: 75mm
 Pole gap: 30mm
 Modulation Coil Modulation Coil Power Supply: Kepco 20V/5A
 Field Mete SENIS 5T/10V

- Note 1: Modulation coil serial connectwed.
- Note 2: Votage Readback PS output terminal voltage divider
- Note 3: Current readback: DF860R, 40A/10V.
- Note 4: Only modulation power supply on. Main power supply is off.
- Note 5: I program through front panel, analog.

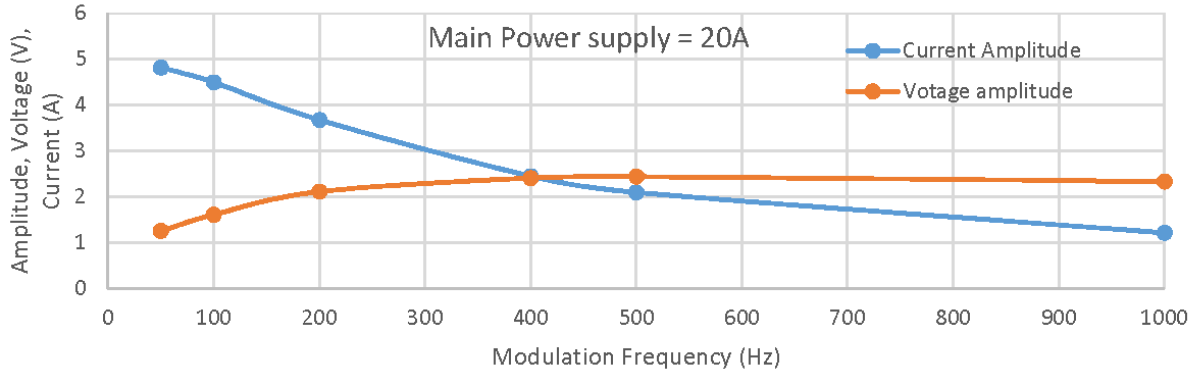
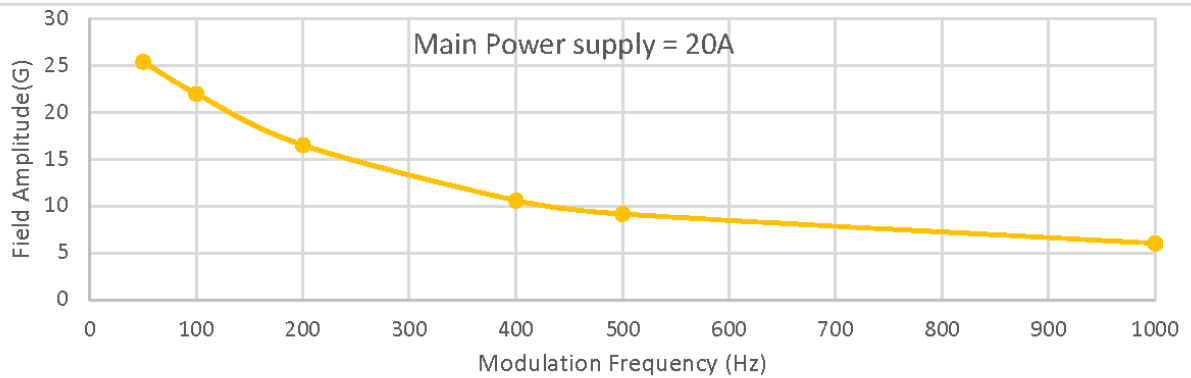
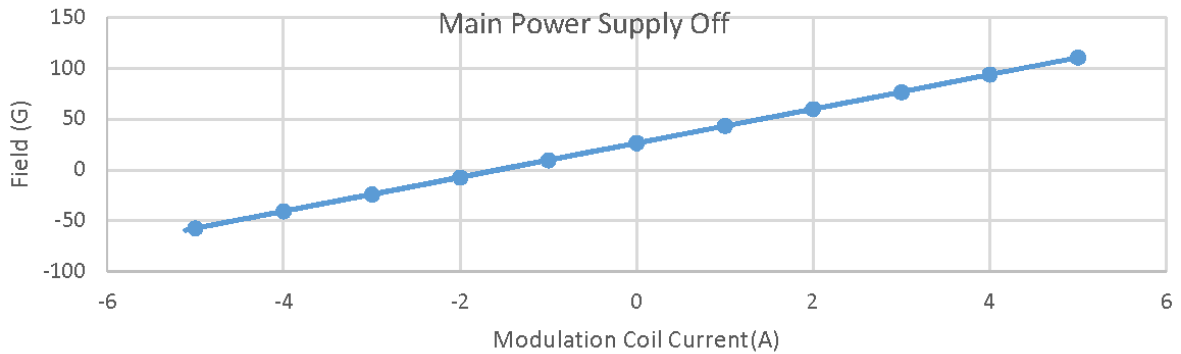

GMW Associates

Electromagnet Excitation Plot

Contract No: Page: 2 of 6 Test Date: 6/13/2018
Customer: Engr: Y.Qin

Magnet 3474-140 Main Power supply: PowerTen 10V/150A
Pole face: 75mm
Pole gap: 50mm
Modulator 5494 Modulation Coil Power Supply: Kepco 20V/5A
Field Meter SENIS 5T/10V

- Note 1: Modulation coil serial connected.
- Note 2: Voltage Readback PS output terminal voltage divider
- Note 3: Current readback: DF860R, 40A/10V.
- Note 4: Only modulation power supply on. Main power supply is off.
- Note 5: I program through front panel, analog.

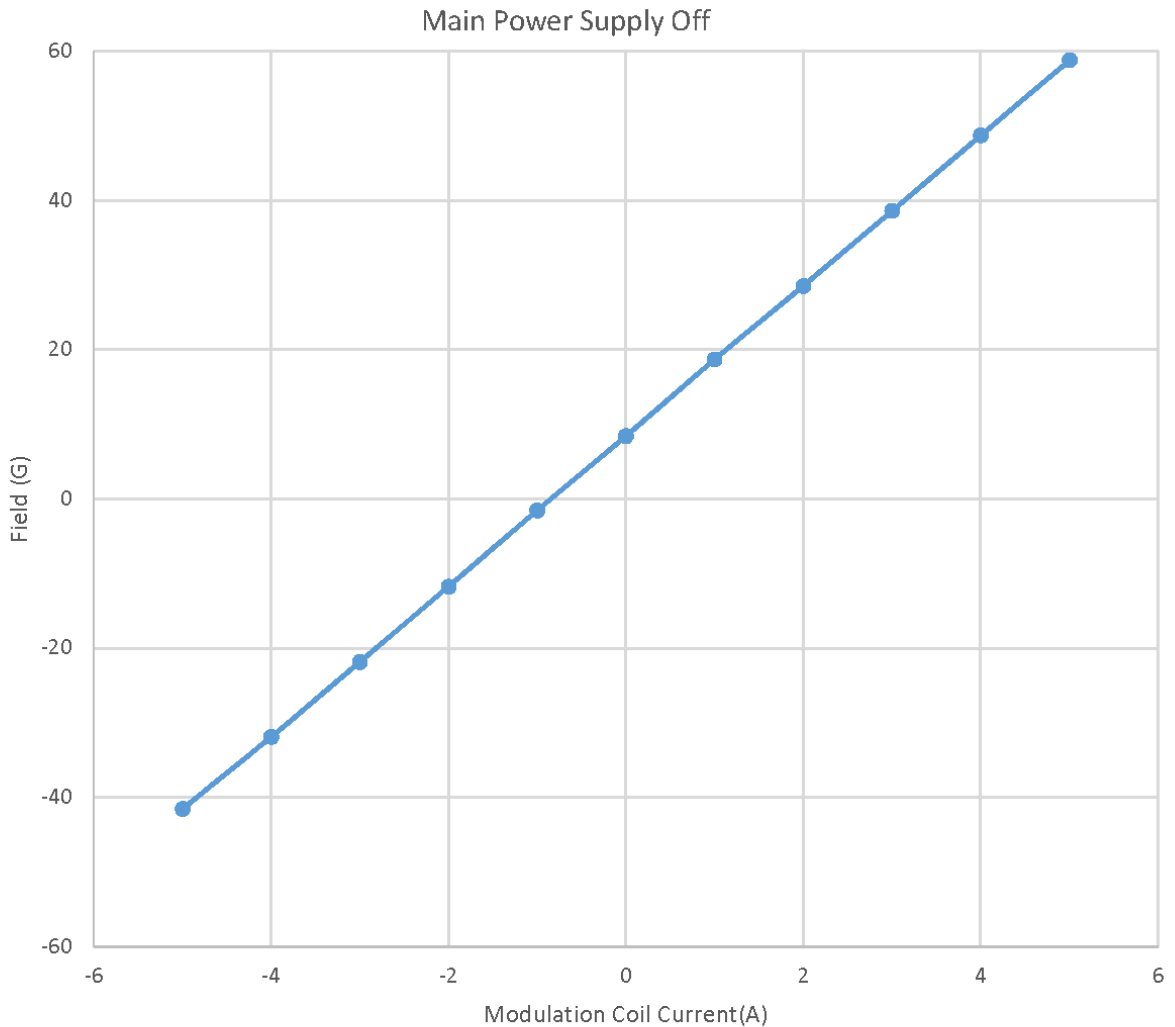

GMW Associates

Electromagnet Excitation Plot

Contract No:

Page: 3 of 6

Test Date: 6/13/2018

Customer:

Engr: Y.Qin

Magnet 3474-140

Main Power supply: PowerTen 10V/150A

Pole face: 75mm

Pole gap: 50mm

Modulator 5494

Modulation Coil Power Supply: Kepco 20V/5A

Field Meter SENIS 5T/10V

Note 1: Modulation coil serial connected.

Note 2: Voltage Readback PS output terminal voltage divider

Note 3: Current readback: DF860R, 40A/10V.

Note 4: Only modulation power supply on. Main power supply is off.

Note 5: I program through front panel, analog.

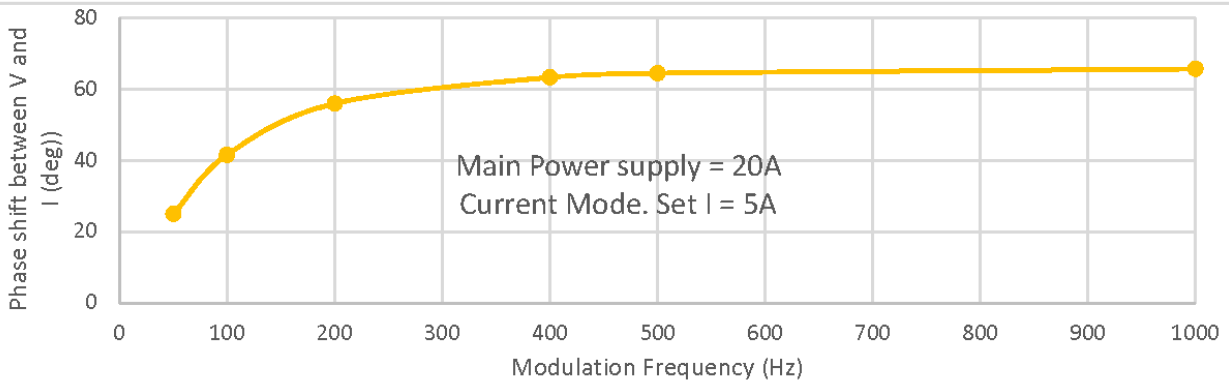
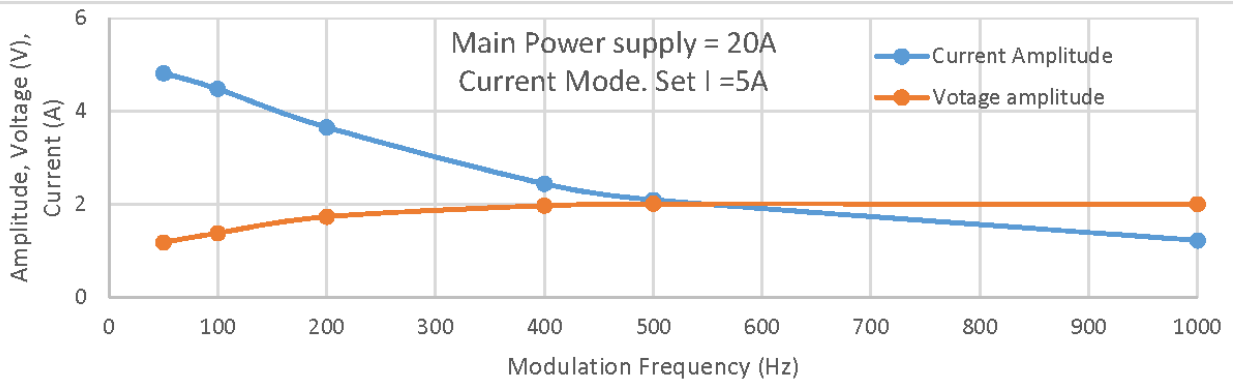
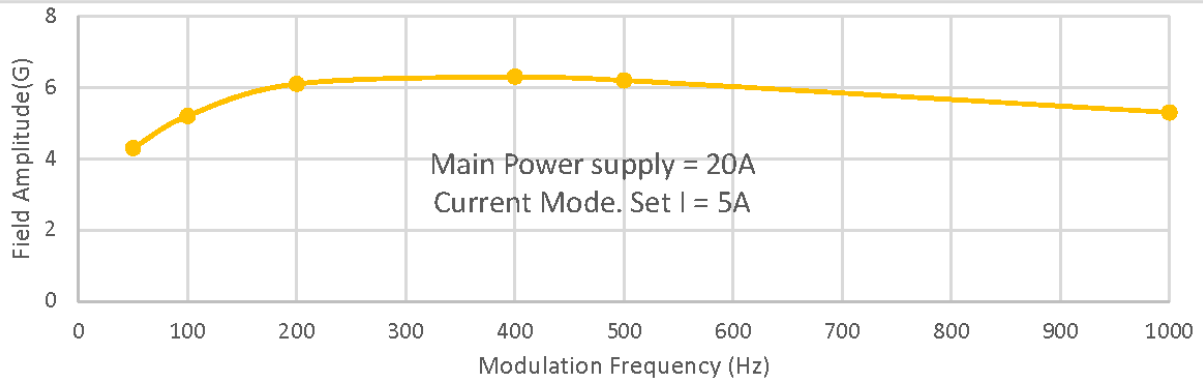

GMW Associates

Electromagnet Excitation Plot

Contract No:

Page: 4 of 6

Test Date: 6/13/2018

Customer:

Engr: Y.Qin

Magnet 3474-140

Main Power supply: PowerTen 10V/150A

Pole face: 75mm

Pole gap: 50mm

Modulator 5494

Modulation Coil Power Supply: Kepco 20V/5A

Field Meter SENIS 5T/10V

Note 1: Modulation coil serial connected.

Note 2: Voltage Readback PS output terminal voltage divider

Note 3: Current readback: DF860R, 40A/10V.

Note 4: Only modulation power supply on. Main power supply is off.

Note 5: I program through front panel, analog.

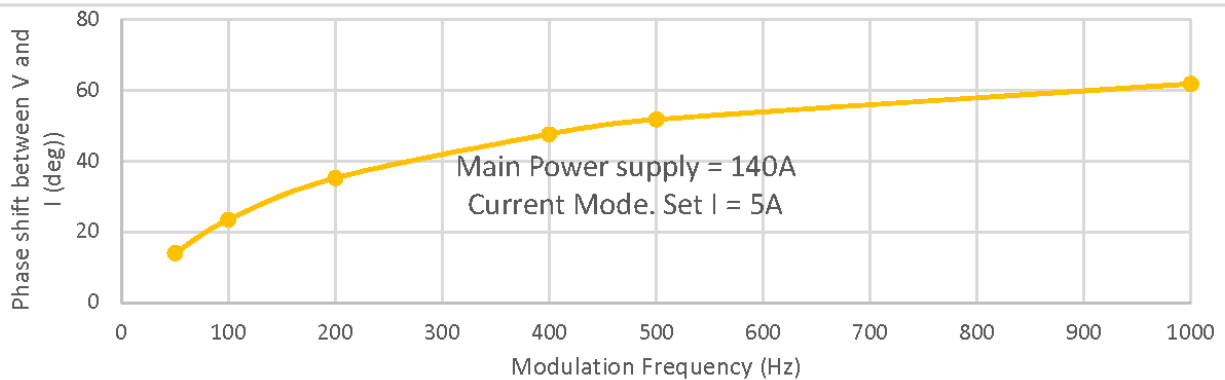
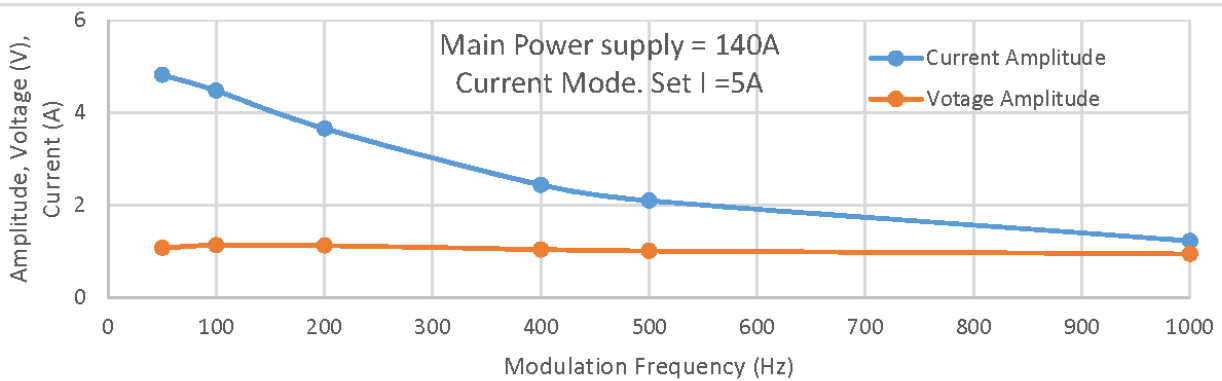
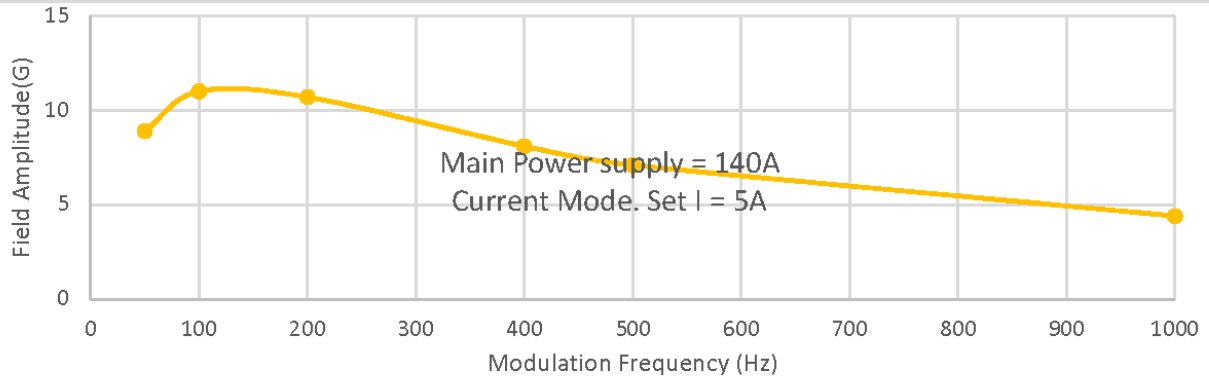

GMW Associates

Electromagnet Excitation Plot

Contract No: Page: 5 of 6 Test Date: 6/13/2018
Customer: Engr: Y.Qin

Magnet 3474-140 Main Power supply: PowerTen 10V/150A
Pole face: 75mm
Pole gap: 50mm
Modulator 5494 Modulation Coil Power Supply: Kepco 20V/5A
Field Meter SENIS 5T/10V

- Note 1: Modulation coil serial connected.
- Note 2: Voltage Readback PS output terminal voltage divider
- Note 3: Current readback: DF860R, 40A/10V.
- Note 4: Only modulation power supply on. Main power supply is off.
- Note 5: I program through front panel, analog.

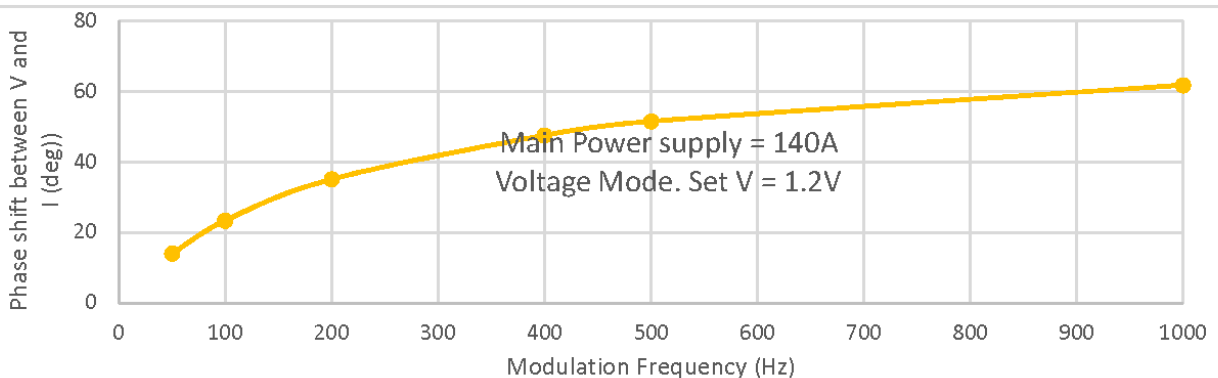
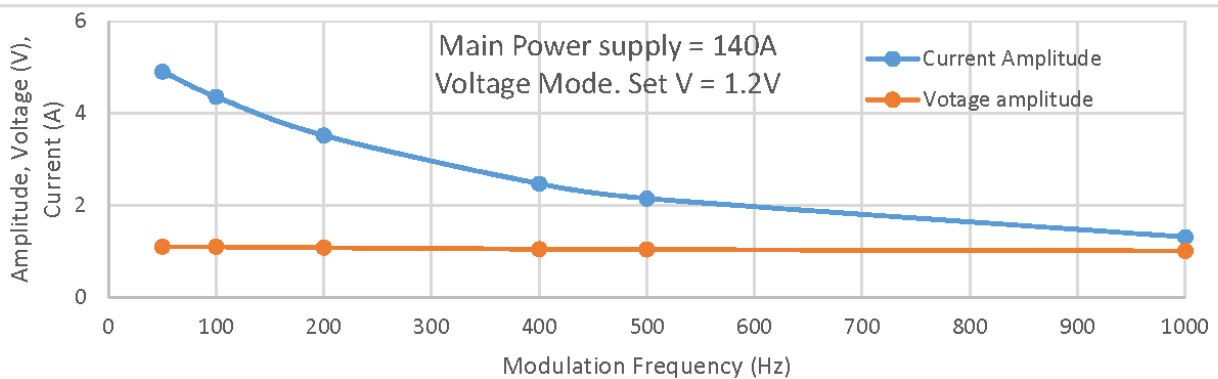
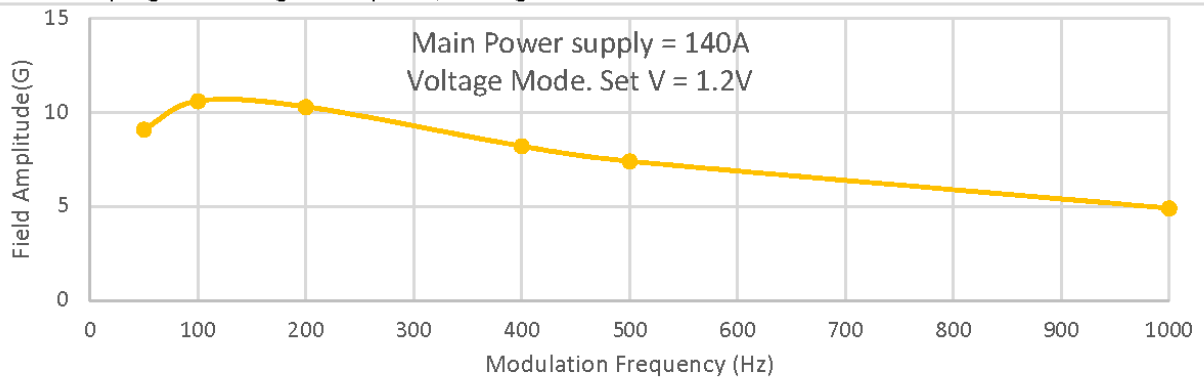

GMW Associates

Electromagnet Excitation Plot

Contract No: Page: 6 of 6 Test Date: 6/13/2018
Customer: Engr: Y.Qin

Magnet 3474-140 Main Power supply: PowerTen 10V/150A
Pole face: 75mm
Pole gap: 50mm
Modulator 5494 Modulation Coil Power Supply: Kepco 20V/5A
Field Meter SENIS 5T/10V

- Note 1: Modulation coil serial connected.
- Note 2: Voltage Readback PS output terminal voltage divider
- Note 3: Current readback: DF860R, 40A/10V.
- Note 4: Only modulation power supply on. Main power supply is off.
- Note 5: I program through front panel, analog.

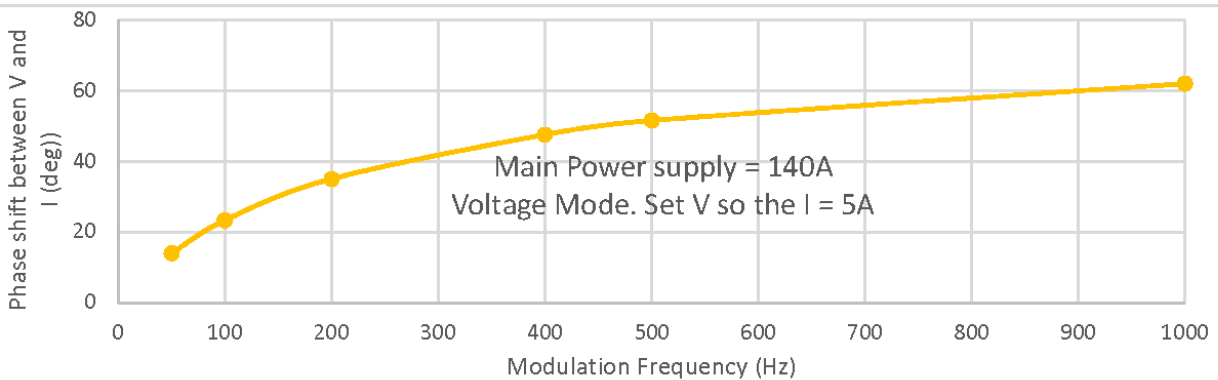
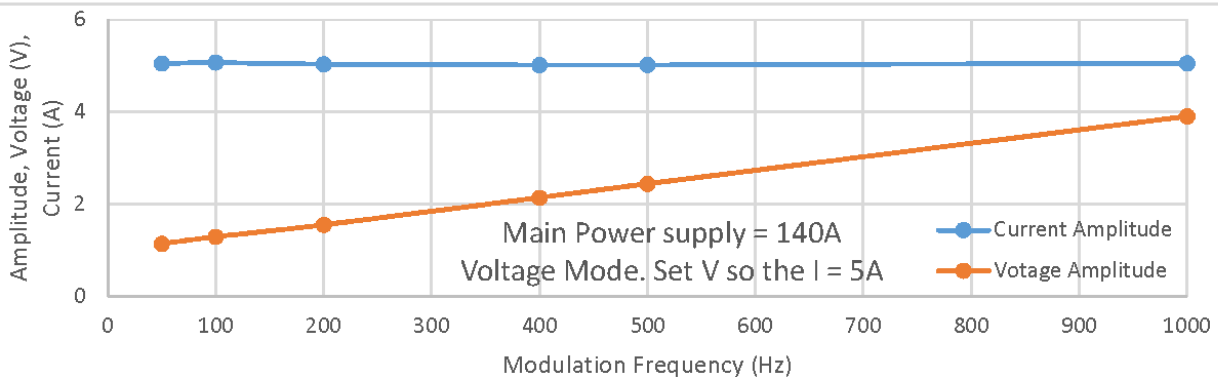
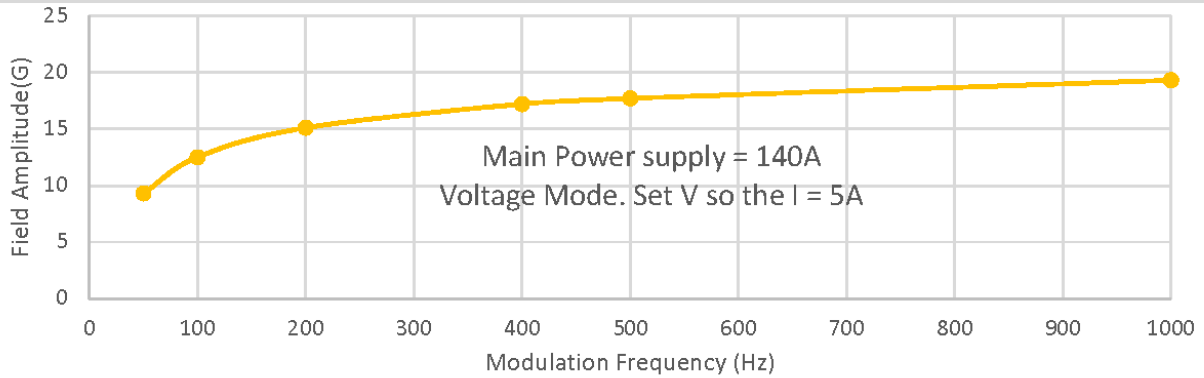

9. FIELD UNIFORMITY PLOTS, STANDARD POLES

FIELD vs POSITION

9.1 Field vs Position 200mm Pole Face, 130mm Gap

Outlier squares in the plots are measurement error.

3474-140 @ 130mm Gap, 200mm Face

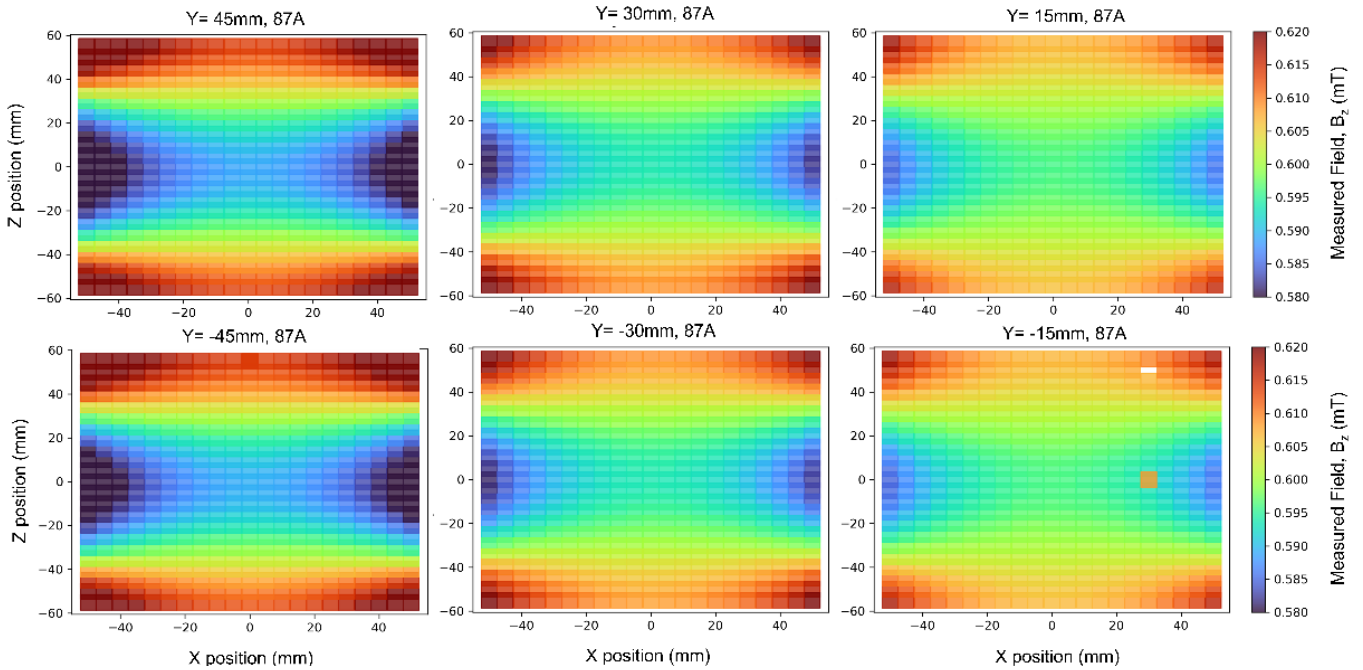
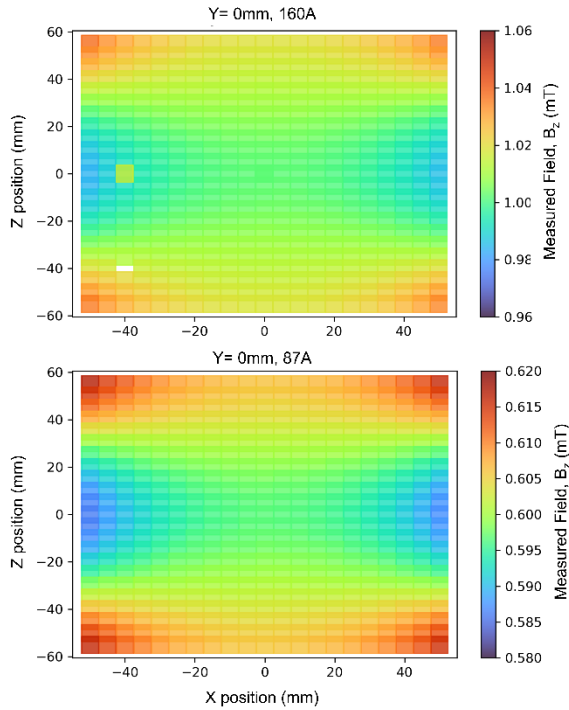
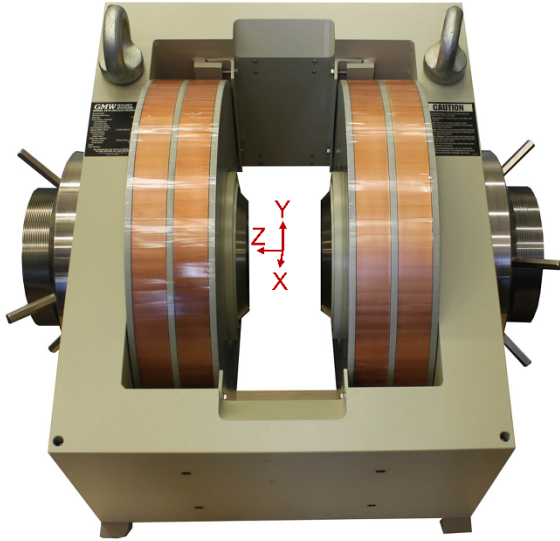

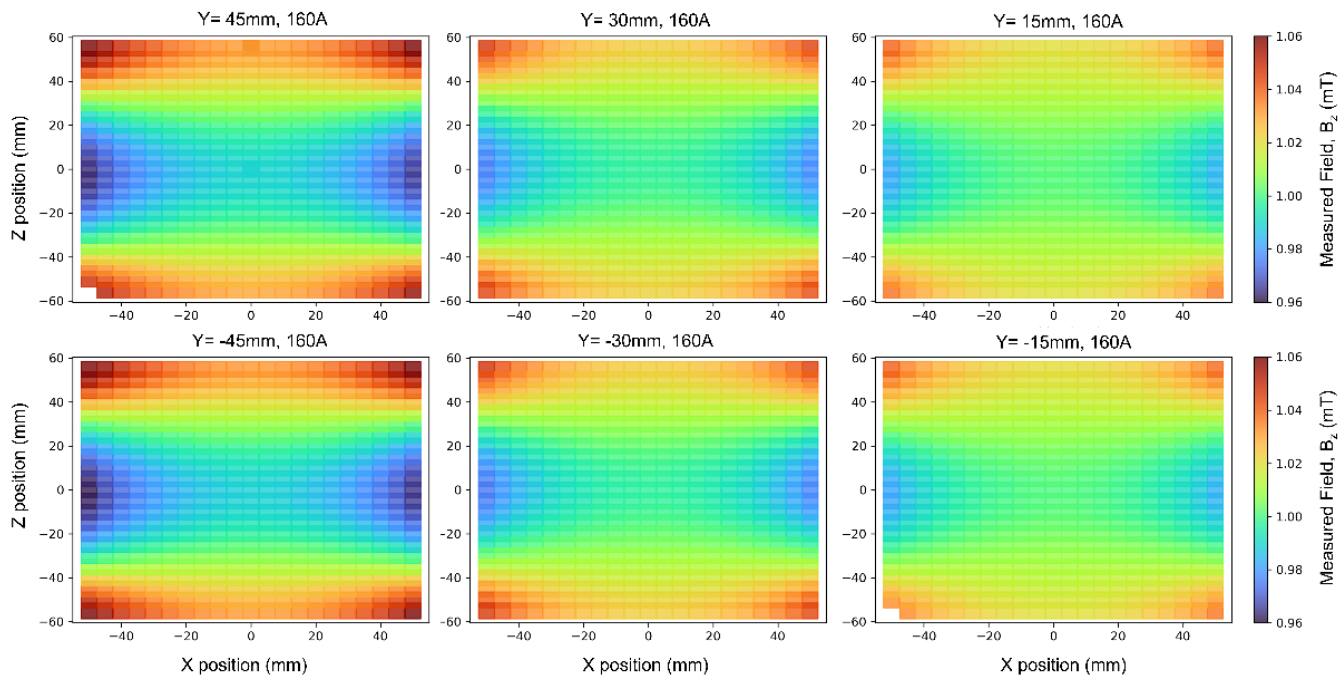

9.2 Field vs Position 250mm Pole Face, 10 to 160mm Gap

Contract No:	Page: 1 of 2	Date: Sept 28, 2004
Customer:	Fixed Axis: Y=0, Z=0	Engr: G. Douglas
Model: 3474	Power Supply:	Set Current: 140 Amps
Serial No: None	Serial No:	Target Field:
Pole Face: 250mm	Teslameter:	Probe:
Pole Gap: 10 to 160mm	Notes: Data taken in Magneto simulation software	
Pole Spacers: None		

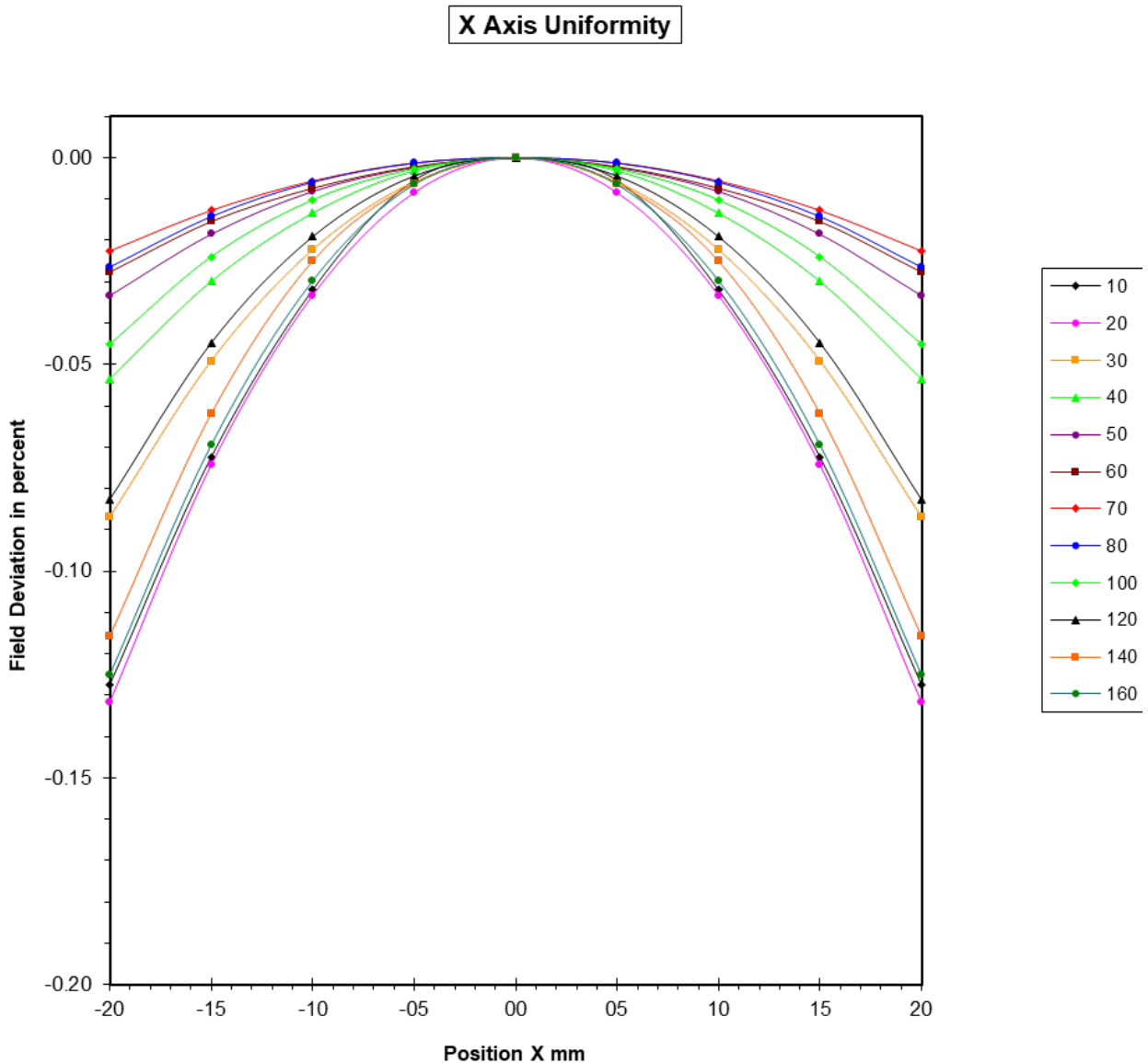

Filename: 3474-250pf-10-160gap_Un1_140A_X-Axis

Contract No:	Page: 2 of 2	Date: Sept 28, 2004
Customer:	Fixed Axis: Y=0, X=0	Engr: G. Douglas
Model: 3474	Power Supply:	Set Current: 140 Amps
Serial No: None	Serial No:	Target Field:
Pole Face: 250mm	Teslameter:	Probe:
Pole Gap: 10 to 160mm	Notes: Data taken in Magneto simulation software	
Pole Spacers: None		

Z Axis Uniformity

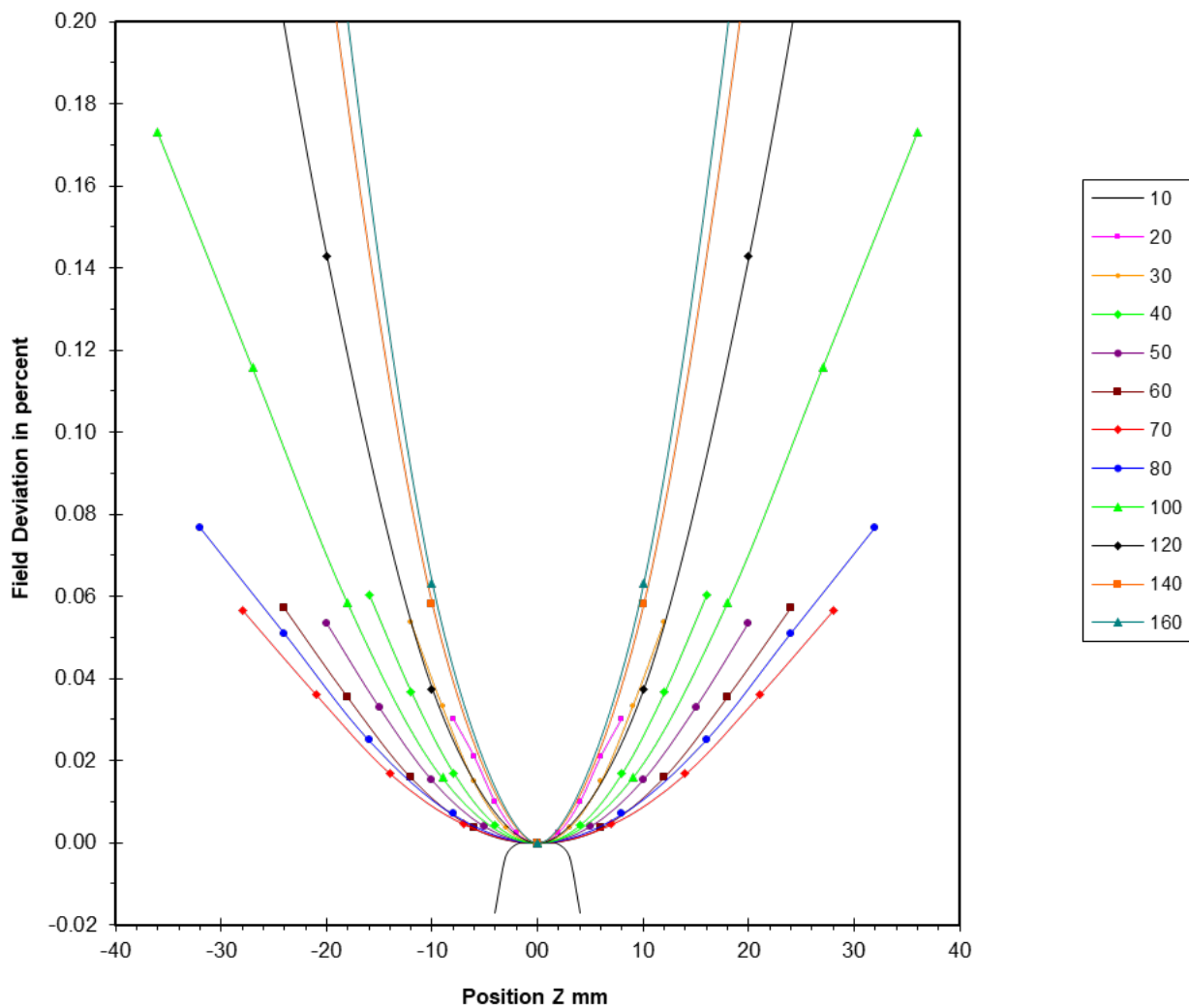

Filename: 3474-250pf-10-160gap_Un1_140A_Z-Axis

9.3 Field vs Position 250mm Pole Face, 120mm Gap

Contract No:	Page: 1 of 2	Date: May 06, 2014
Customer:	Fixed Axis: Y=0, Z=0	Engr: G. Douglas
Model: 3474	Power Supply:	Set Current: 140 Amps
Serial No: None	Serial No:	Target Field:
Pole Face: 250mm	Teslameter:	Probe:
Pole Gap: 120mm	Notes: Data taken in Magneto simulation software	
Pole Spacers: None		

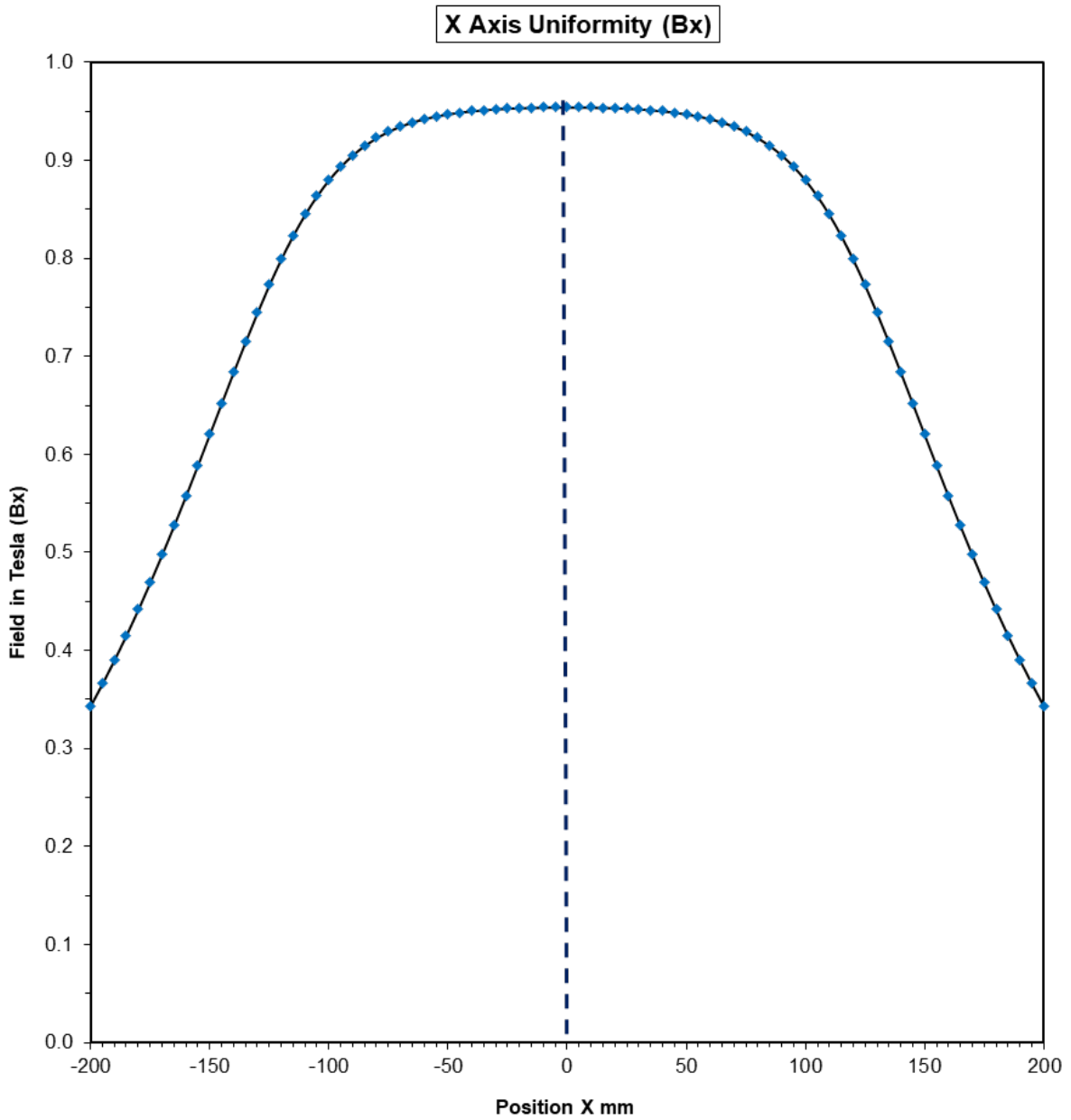

Filename: 3474-250pf-120gap_Un2_140A_P200-M200_XZ-Axis

Contract No:

Page: 2 of 2

Date: May 06, 2014

Customer:

Fixed Axis: X=0, Z=0

Engr: G. Douglas

Model: 3474

Power Supply:

Set Current: 140 Amps

Serial No: None

Serial No:

Target Field:

Pole Face: 250mm

Teslameter:

Probe:

Pole Gap: 120mm

Notes: Data taken in Magneto simulation software

Pole Spacers: None

Z Axis Uniformity (Bz)

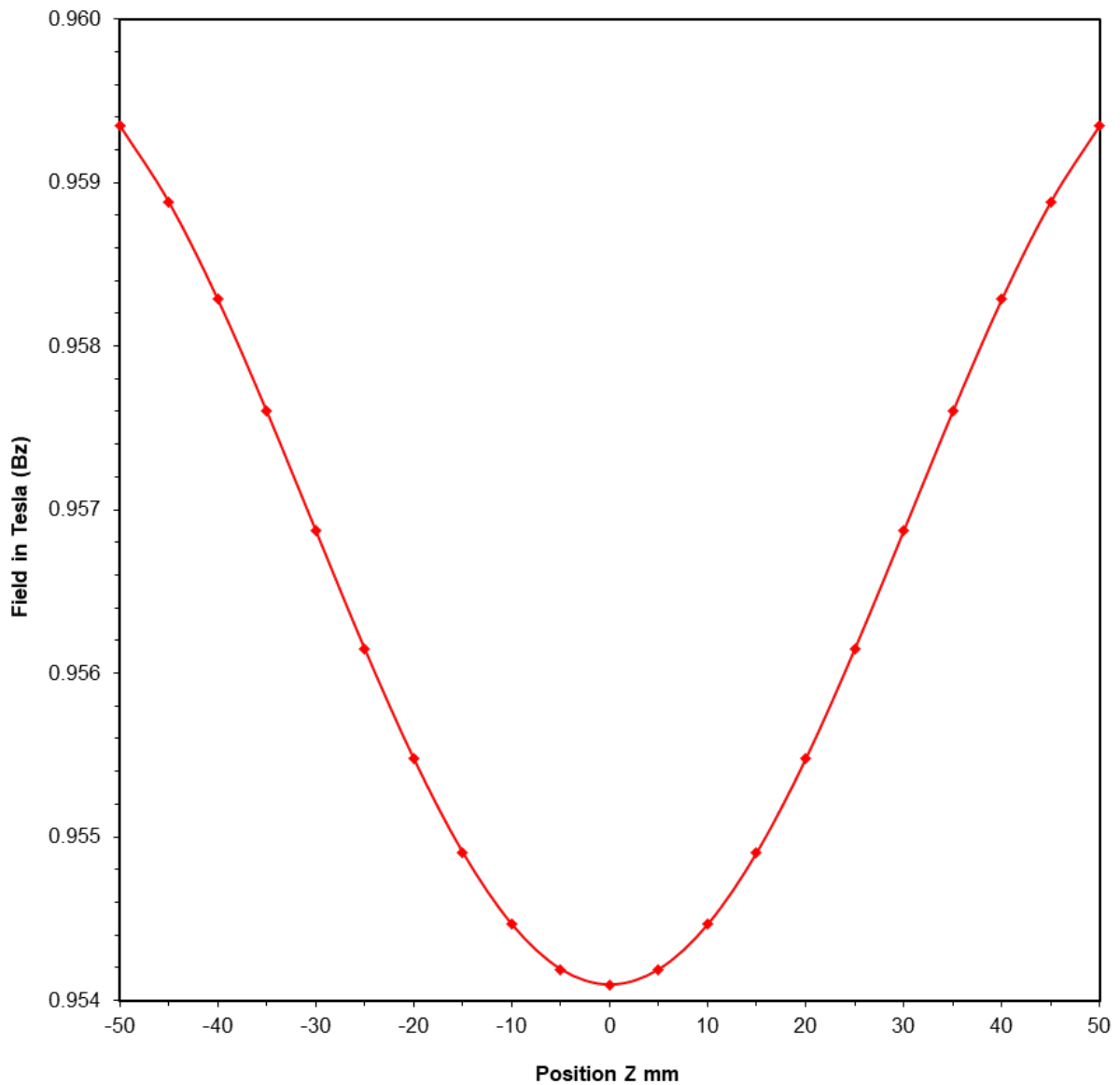

Filename: 3474-250pf-120gap_Un2_140A_P200-M200_XZ-Axis

9.4 Field vs Position 250mm Pole Face, 50mm Gap

Contract No:	Page: 1 of 2	Date: Feb 01, 2008
Customer:	Fixed Axis: X=0, Z=0	Engr: G. Douglas
Model: 3474	Power Supply:	Set Current: 60 Amps
Serial No: None	Serial No:	Target Field:
Pole Face: 250mm	Teslameter:	Probe:
Pole Gap: 50mm	Notes: Data taken in Magneto simulation software	
Pole Spacers: None		

Z Axis Uniformity

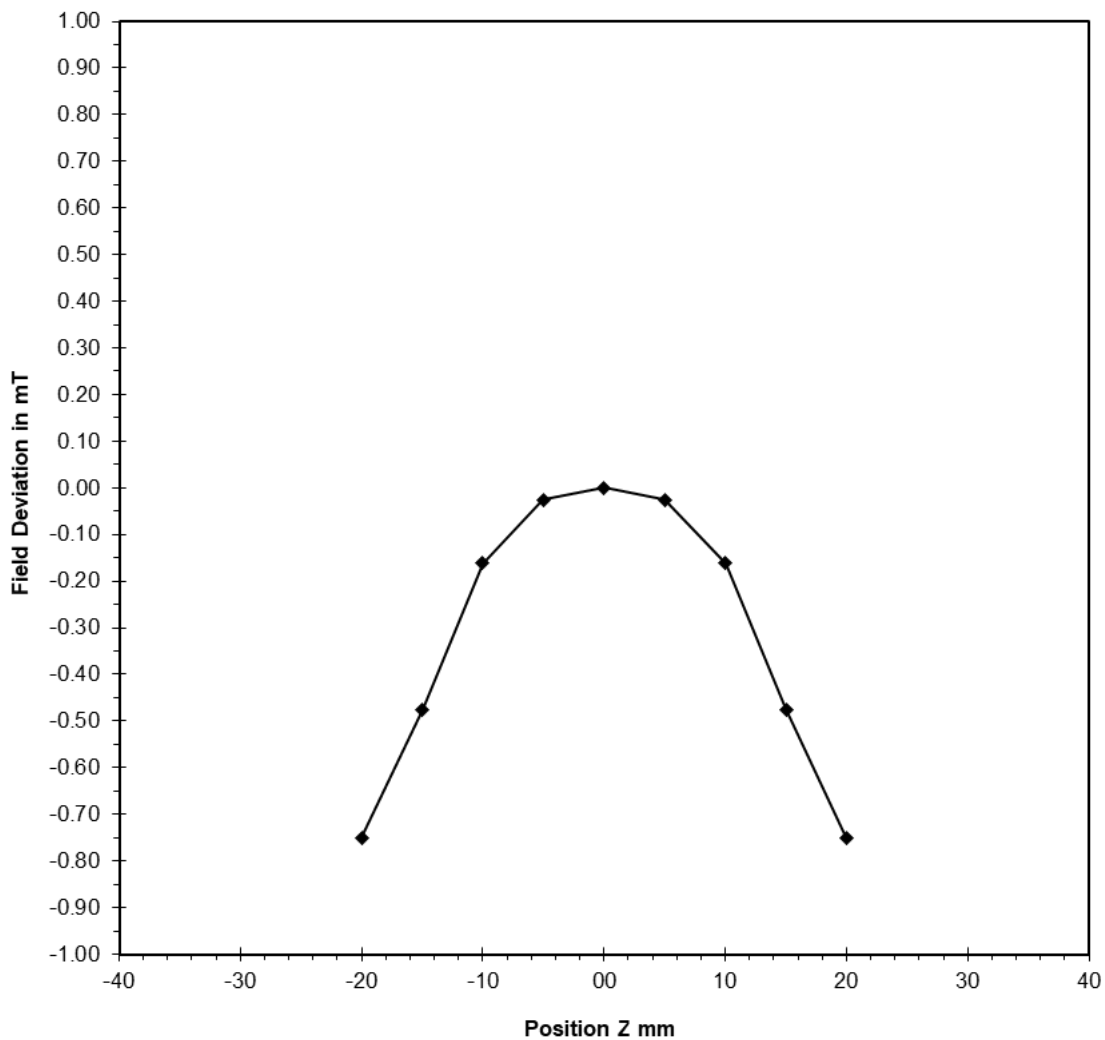

Filename: 3474-250pf-50gap_Un1_60A_Y-Axis

Contract No:	Page: 2 of 2	Date: Feb 01, 2008
Customer:	Fixed Axis: Y=0, Z=0	Engr: G. Douglas
Model: 3474	Power Supply:	Set Current: 60 Amps
Serial No: None	Serial No:	Target Field:
Pole Face: 250mm	Teslameter:	Probe:
Pole Gap: 50mm	Notes: Data taken in Magneto simulation software	
Pole Spacers: None		

X Axis Uniformity

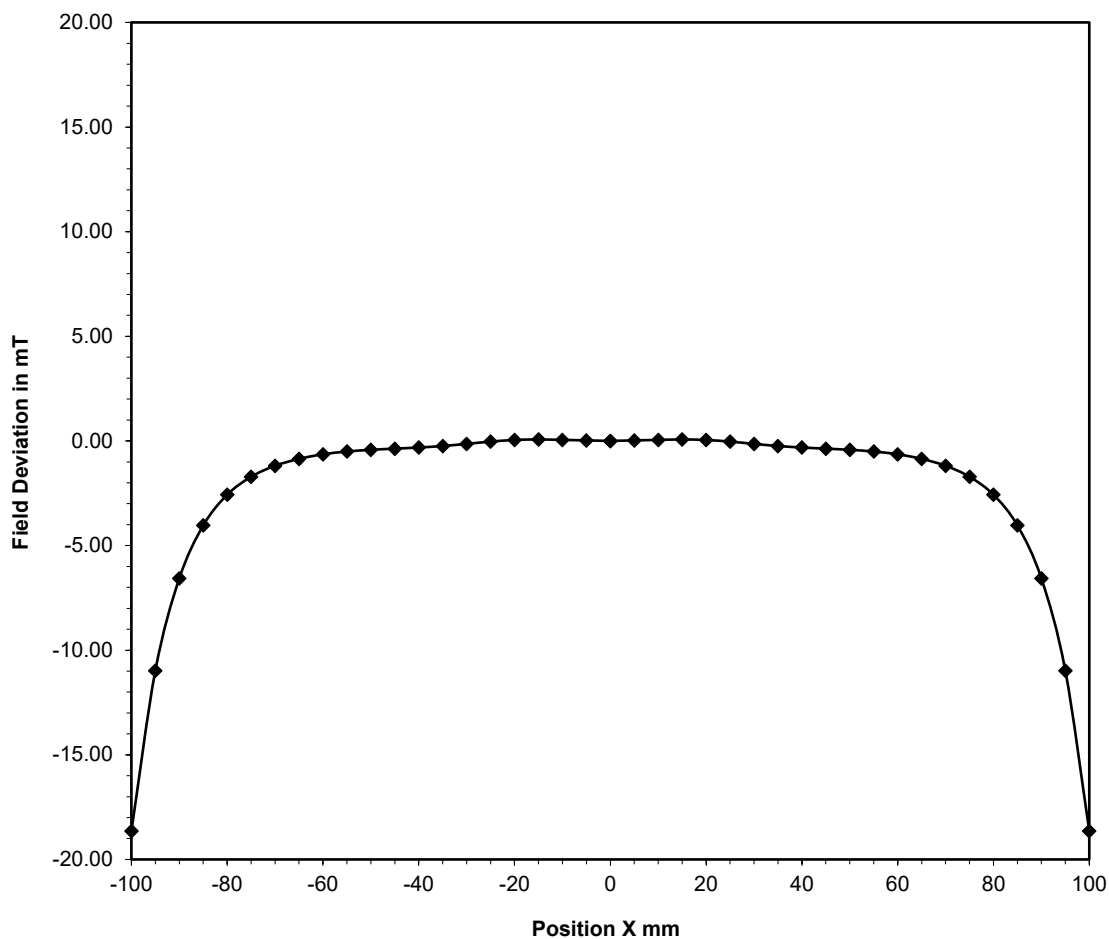

Filename: 3474-250pf-50gap_Un1_60A_X-Axis

9.5 Field vs Position 250mm Pole Face, 30mm Gap

Contract No:	Page: 1 of 2	Date: May 14, 2009
Customer:	Fixed Axis: Y=0, Z=0	Engr: G. Douglas
Model: 3474	Power Supply:	Set Current: 140 Amps
Serial No: None	Serial No:	Target Field:
Pole Face: 250mm	Teslameter:	Probe:
Pole Gap: 30mm	Notes: Data taken in Magneto simulation software	
Pole Spacers: None		

X Axis Uniformity

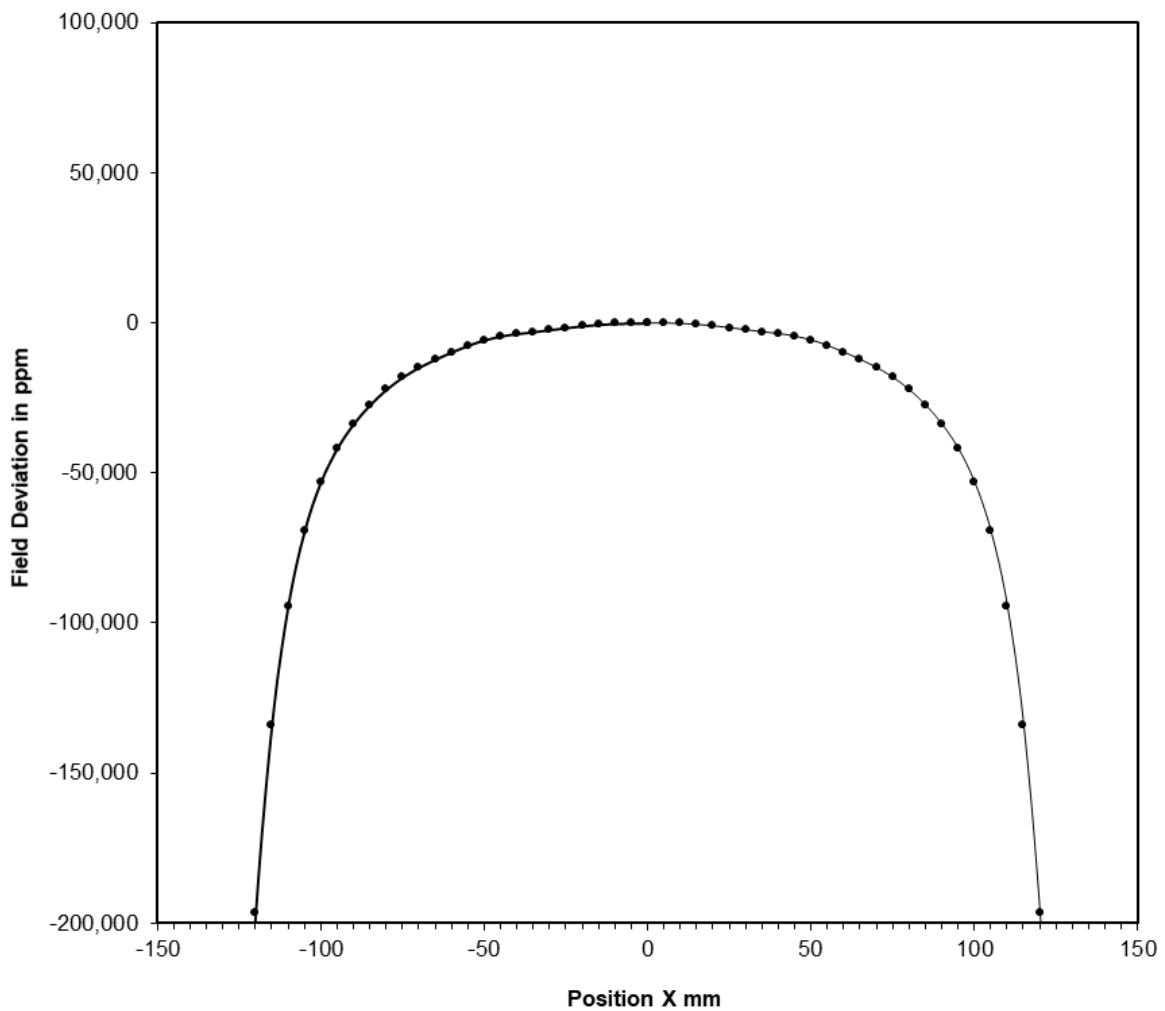

Filename: 3474-250pf-30gap_Un1_140A_X-Axis-2

Contract No:

Page: 2 of 2

Date: Aug 12, 2009

Customer:

Fixed Axis: $Y=0, Z=0$

Engr: G. Douglas

Model: 3474

Power Supply:

Set Current: 35 Amps

Serial No: None

Serial No:

Target Field: 1 Tesla

Pole Face: 250mm

Teslameter:

Probe:

Pole Gap: 30mm

Notes: Data taken in Magneto simulation software

Pole Spacers: None

X Axis Uniformity [B]

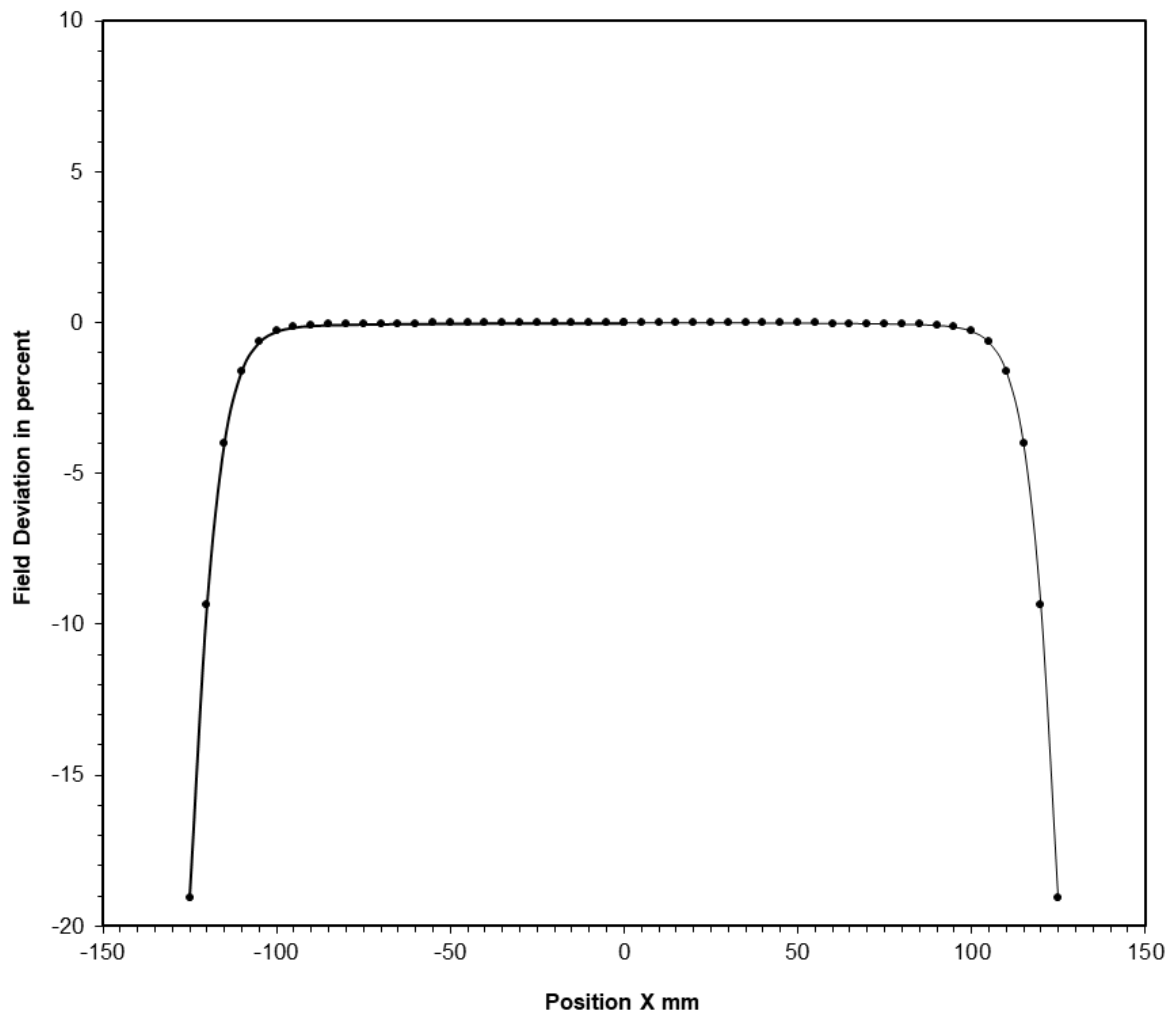

Filename: 3474-250pf-30gap_Un1_35A_X-Axis

9.6 Field vs Position 250mm Pole Face, 25mm Gap

Contract No:	Page: 1 of 1	Date: Aug 12, 2009
Customer:	Fixed Axis: Y=0, Z=0	Engr: G. Douglas
Model: 3474	Power Supply:	Set Current: 30 Amps
Serial No: None	Serial No:	Target Field: 1 Tesla
Pole Face: 250mm	Teslameter:	Probe:
Pole Gap: 25mm	Notes: Data taken in Magneto simulation software	
Pole Spacers: None		

X Axis Uniformity [B]

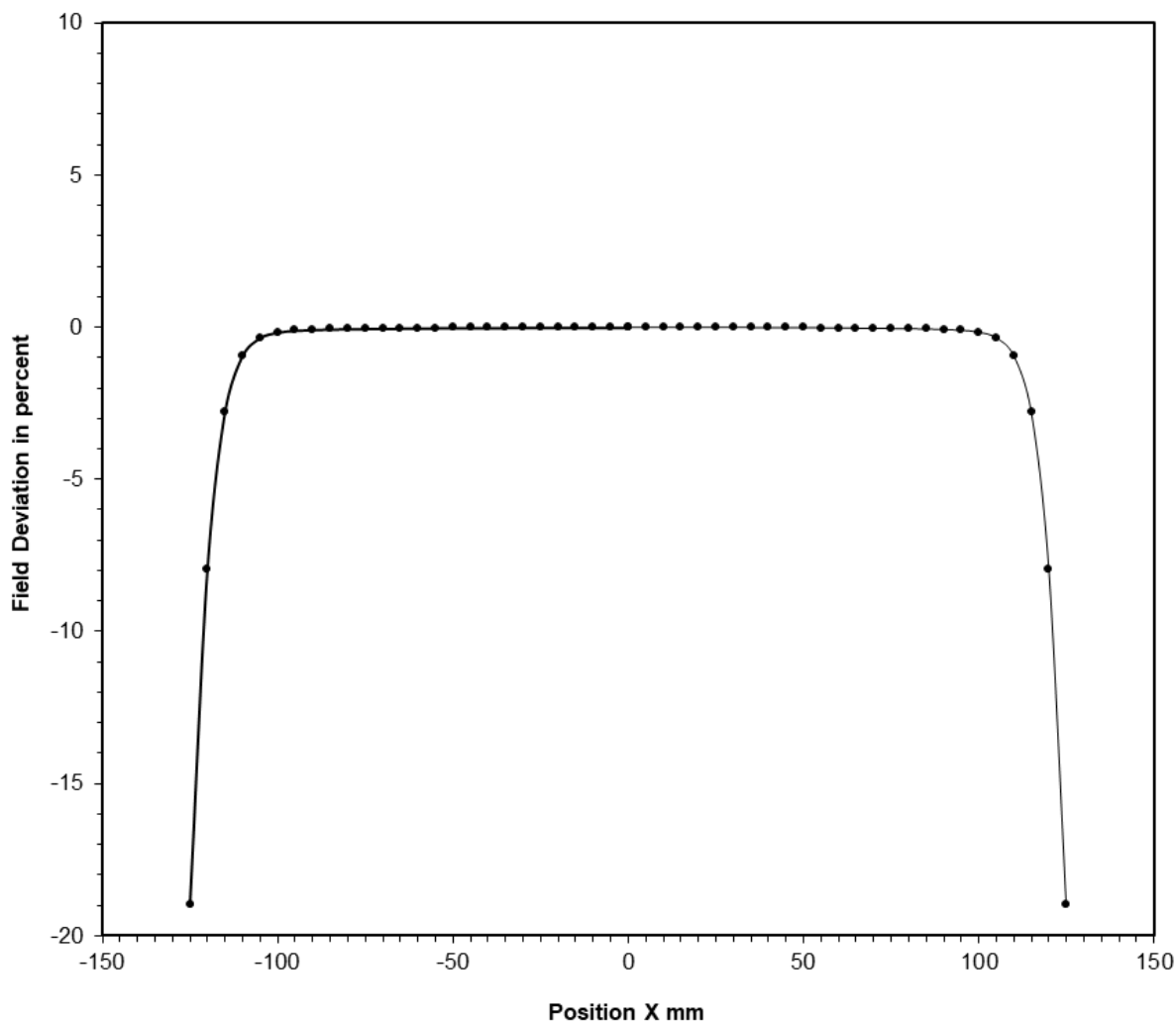

Filename: 3474-250pf-25gap_Un1_30A_X-Axis

9.7 HIGH UNIFORMITY

Specially designed poles, along with GMW's unique pole face alignment technique, allows GMW to offer a High Uniformity option for 3474 Electromagnets. Discuss your field High Uniformity needs with sales@gmw.com and we will design and deliver a 3474 preset to those requirements.

9.7.1 High Uniformity Poles Assembly

These poles can achieve a very high field uniformity and are custom made for specific pole gap and field strength requirements.

This field map was measured (not modeled) on the median plane of the magnet. This is achieved using high uniformity poles and provides field uniformity of order 1ppm for a region of diameter 20mm at 0.5 Tesla field strength.

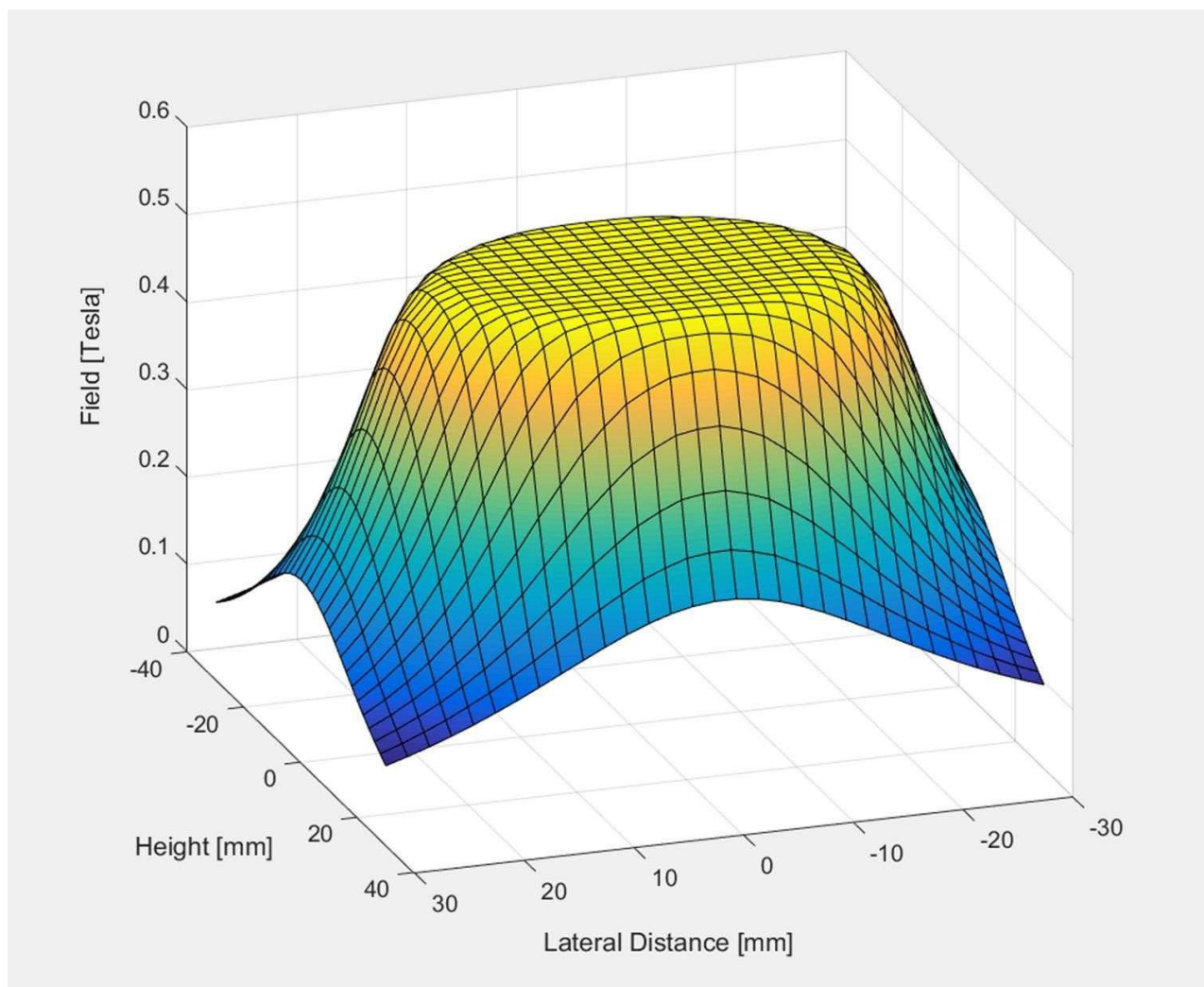

9.8 POLTTING AXIS

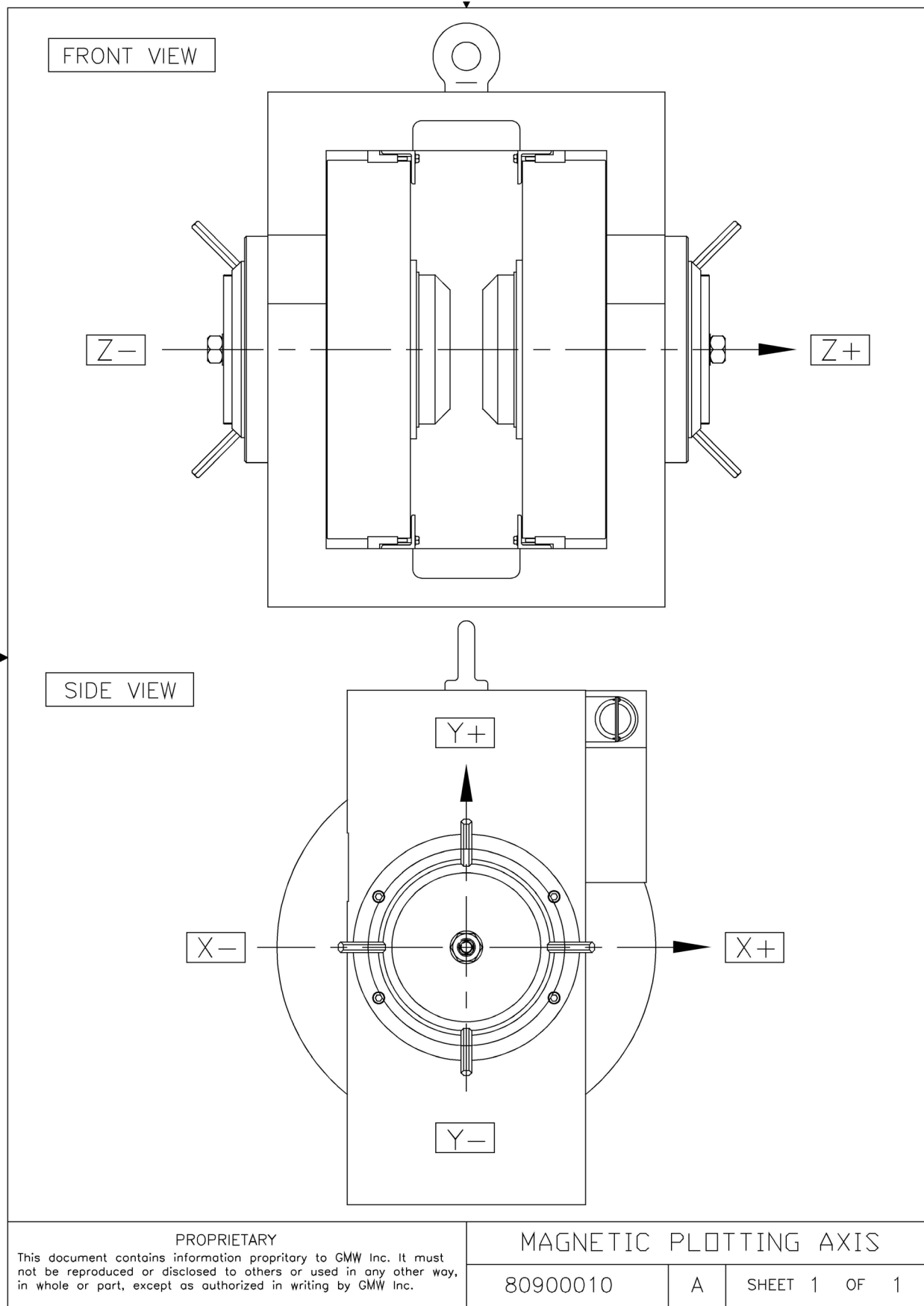

10. 5 GAUSS SURFACE PLOTS

The 5 Gauss Surface is calculated using finite element analysis. The calculations are performed with Opera Version 14.0 Professional Edition x64. The 5 Gauss Surface is calculated at the maximum rated current for the magnet, 35Amps. The model includes only the magnetically significant components of the magnet as seen here surrounded by the 5 Gauss Surface

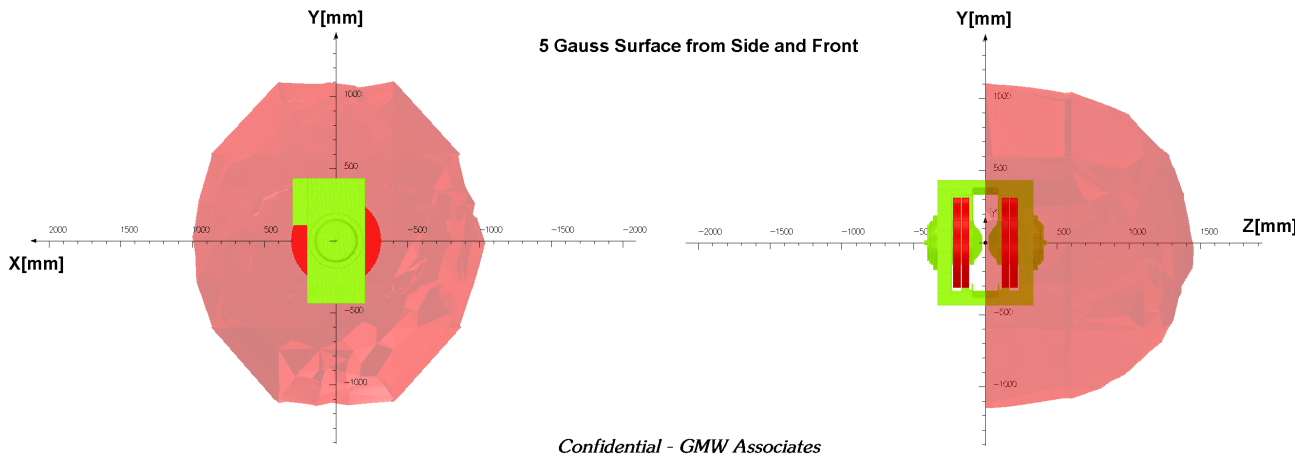
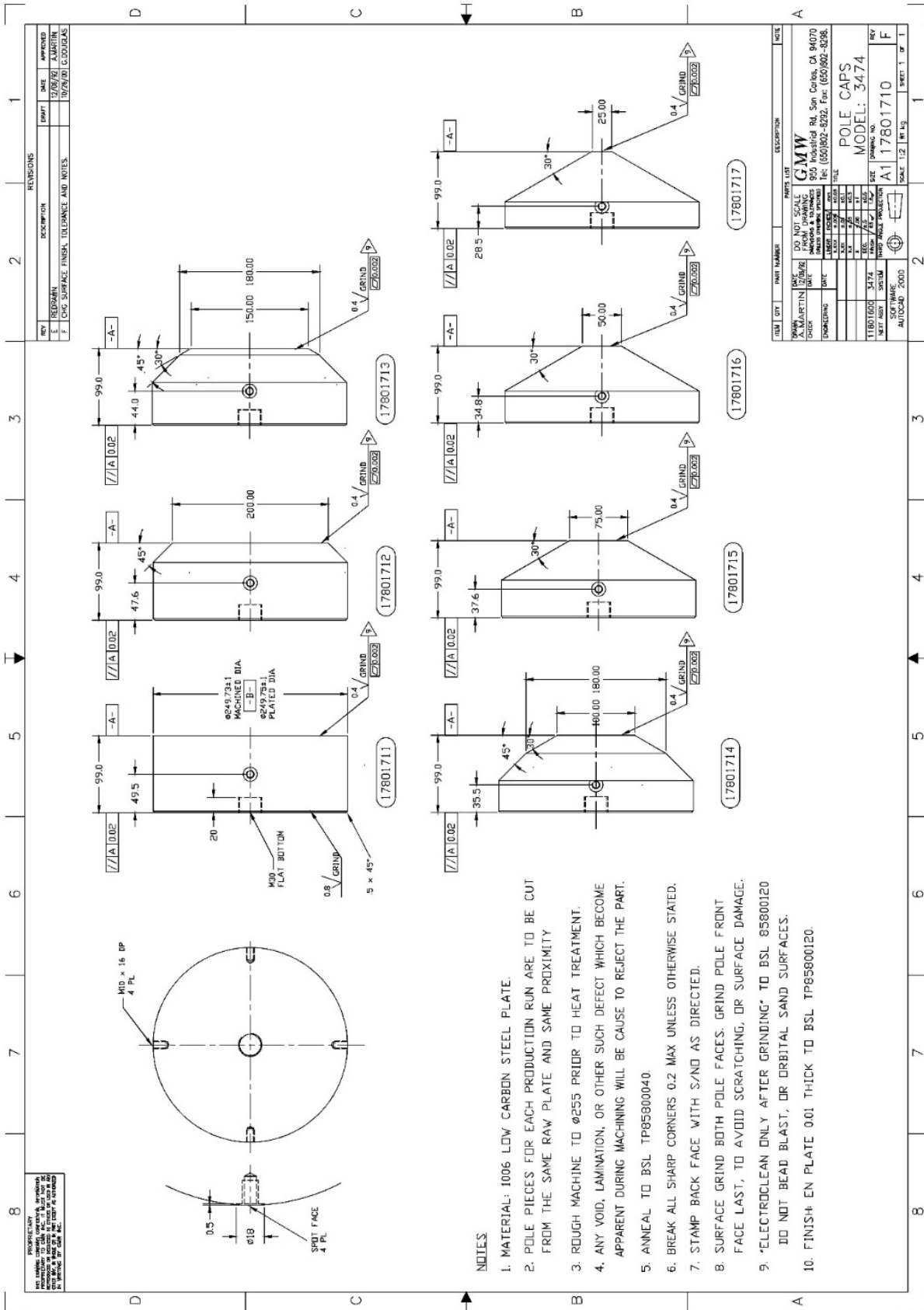

Figure 1: 3474 Electromagnet, 140A Excitation, 5 Gauss Surface, XYZ distance as viewed from the side and front.

11. OPTIONS AND ACCESSORIES DRAWINGS

11.1 Standard Poles

11.1.1 Drawing 17801710 - 3474 Pole Caps



11.2 Custom Pole Options

11.2.1 Drawing 17207-0734-0 3474 300mm Pole Cap

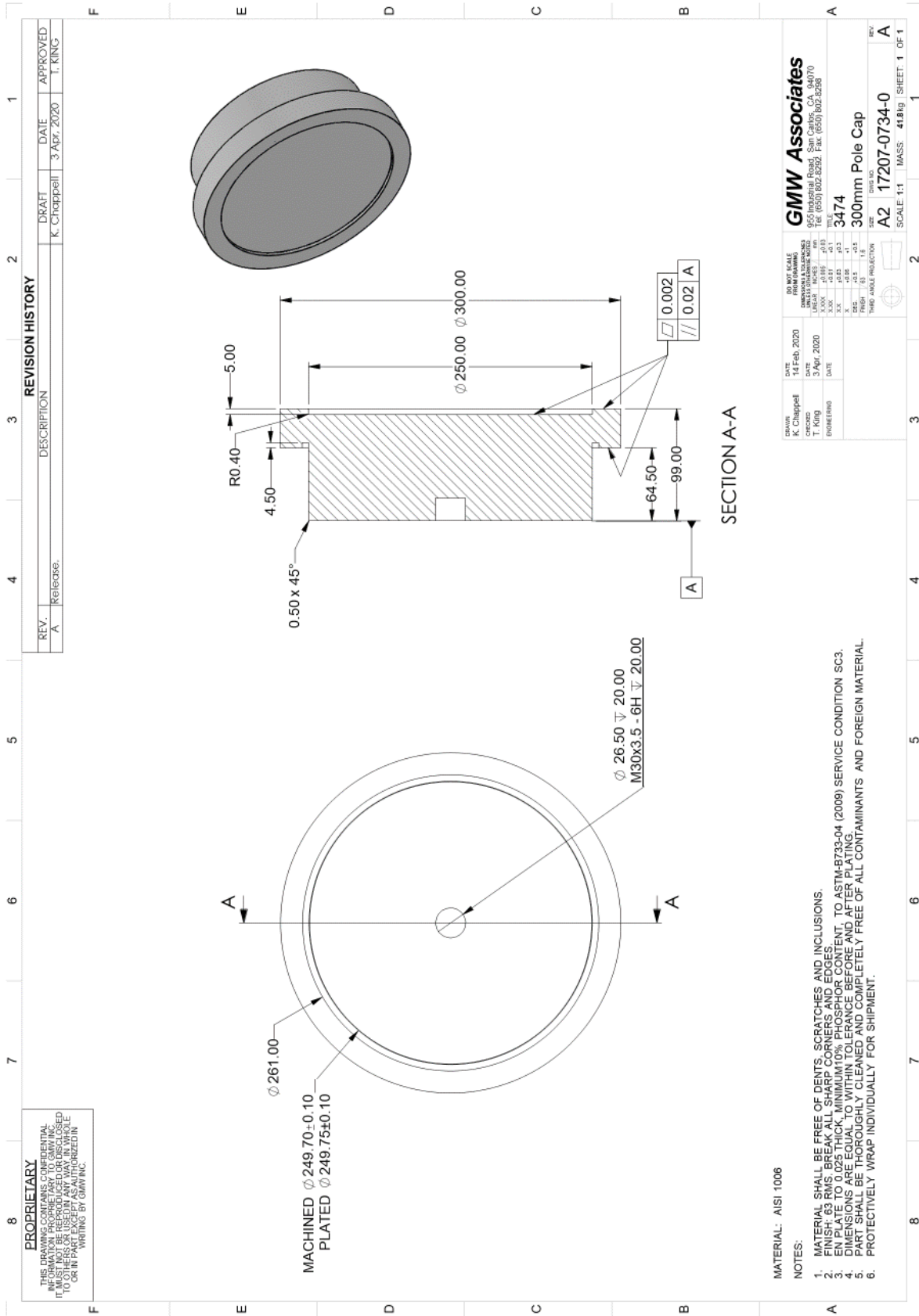

REVISION HISTORY			
REV.	DESCRIPTION	DATE	APPROVED
A	Release.	3 Apr. 2020	T. KING

PROPRIETARY
 THIS DRAWING CONTAINS CONFIDENTIAL INFORMATION. IT IS NOT TO BE REPRODUCED OR DISCLOSED TO OTHERS OR USED IN ANY WAY, IN WHOLE OR IN PART, WITHOUT THE WRITTEN PERMISSION BY GWMI INC.

DATE	14 Feb. 2020	DATE	3 Apr. 2020
DRAWN	A. Chappell	DATE	3 Apr. 2020
ENGINEER	T. King	DATE	3 Apr. 2020
DESIGNED	T. King	DATE	3 Apr. 2020
CHECKED	T. King	DATE	3 Apr. 2020
APPROVED	T. King	DATE	3 Apr. 2020
SCALE	1:1	SCALE	1:1
MASS	41.8 kg	MASS	41.8 kg
SHEET	1	SHEET	1
OF	1	OF	1

NO. NOT SCALE	14 Feb. 2020	DATE	3 Apr. 2020
UNITS	MM	UNITS	MM
LENGTH	MM	LENGTH	MM
AREA	MM ²	AREA	MM ²
VOLUME	MM ³	VOLUME	MM ³
WEIGHT	KG	WEIGHT	KG
FINISH	0.002	FINISH	0.002
THIRD ANGLE PROJECTION		THIRD ANGLE PROJECTION	

MATERIAL: AISI 1006

NOTES:

- MATERIAL SHALL BE FREE OF DENTS, SCRATCHES AND INCLUSIONS.
- FINISH: G3 RMS; BREAK ALL SHARP CORNERS AND EDGES.
- EN PLATE TO 0.025 THICK, MINIMUM 10% PHOSPHOR CONTENT, TO ASTM-B733-04 (2009) SERVICE CONDITION SC3.
- DIMENSIONS ARE EQUAL TO WITHIN TOLERANCE BEFORE AND AFTER PLATING.
- PART SHALL BE THOROUGHLY CLEANED AND COMPLETELY FREE OF ALL CONTAMINANTS AND FOREIGN MATERIAL.
- PROTECTIVELY WRAP INDIVIDUALLY FOR SHIPMENT.

11.2.2 Drawing 12907-2001-0 3474 Pole Cap With 4mm Hole

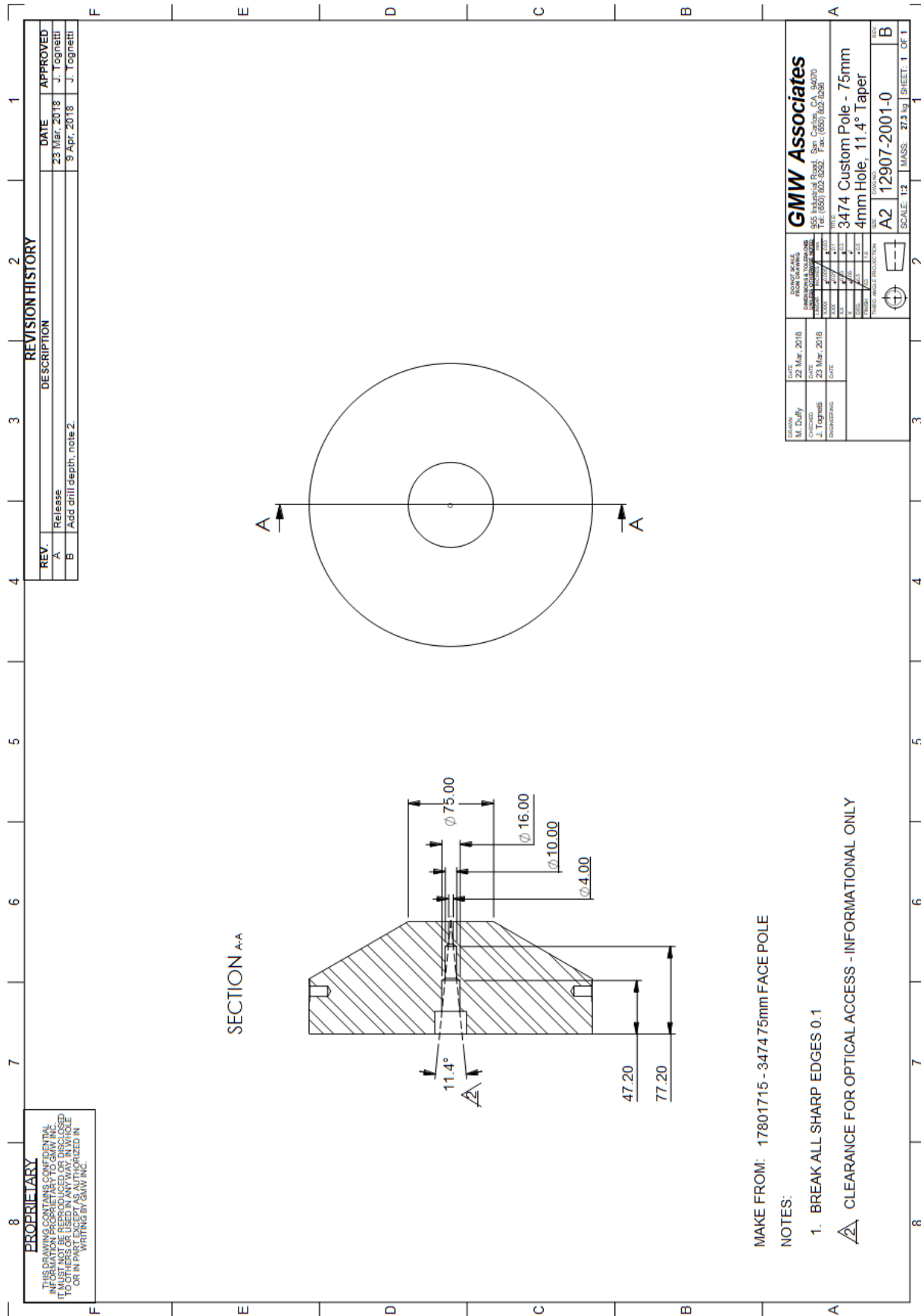

MAKE FROM: 17801715 - 3474 75mm FACE POLE

NOTES:

1. BREAK ALL SHARP EDGES 0.1

CLEARANCE FOR OPTICAL ACCESS - INFORMATIONAL ONLY

11.2.3 Drawing 12207-0005-0 100mm Pole Cap With Mounting Holes

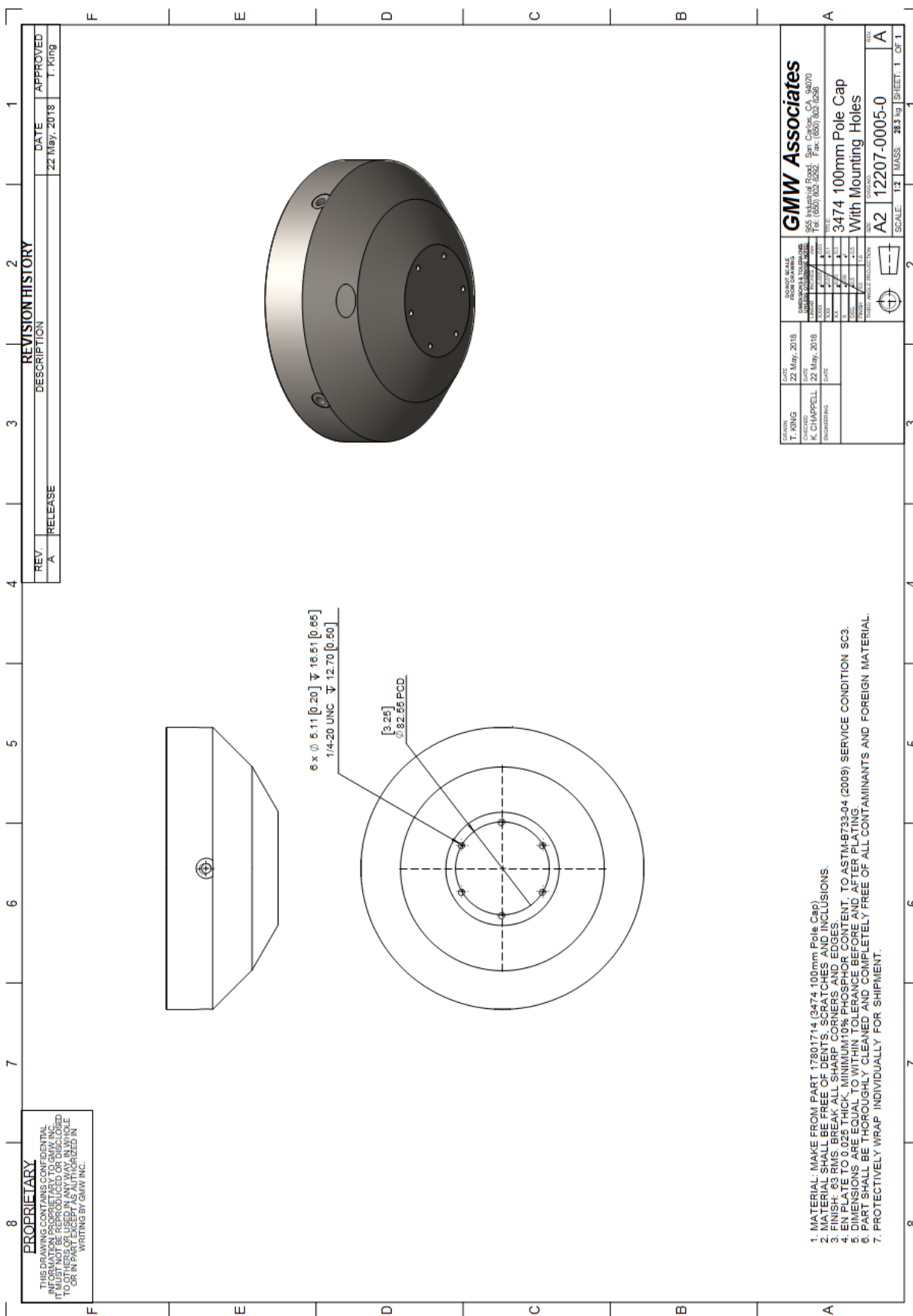

11.3.2 Drawing 11907-0668-0 Probe Holder Transverse, Senis Type 'C'

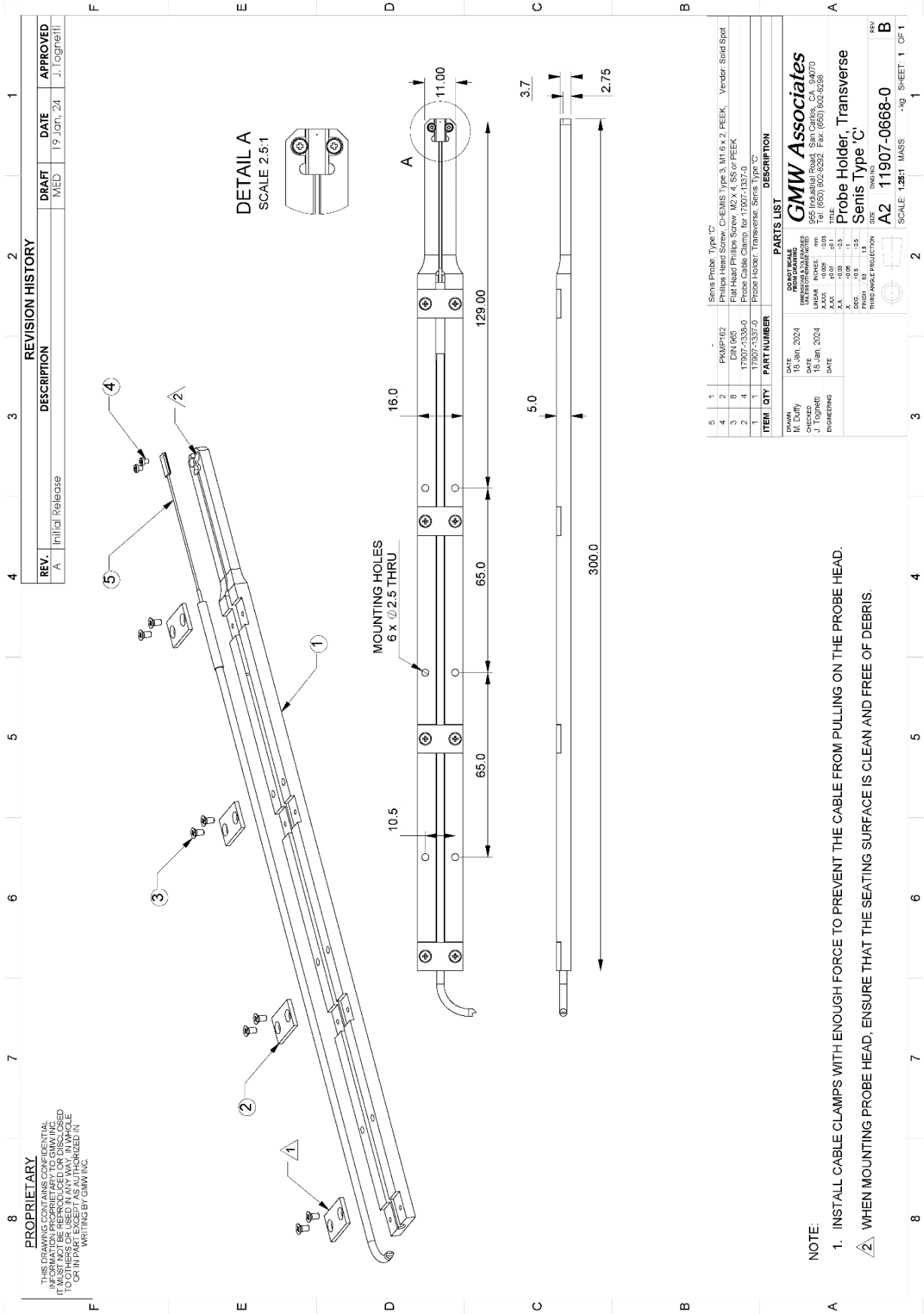

11.3.3 Drawing 11901230 MPT Probe Holder Transverse

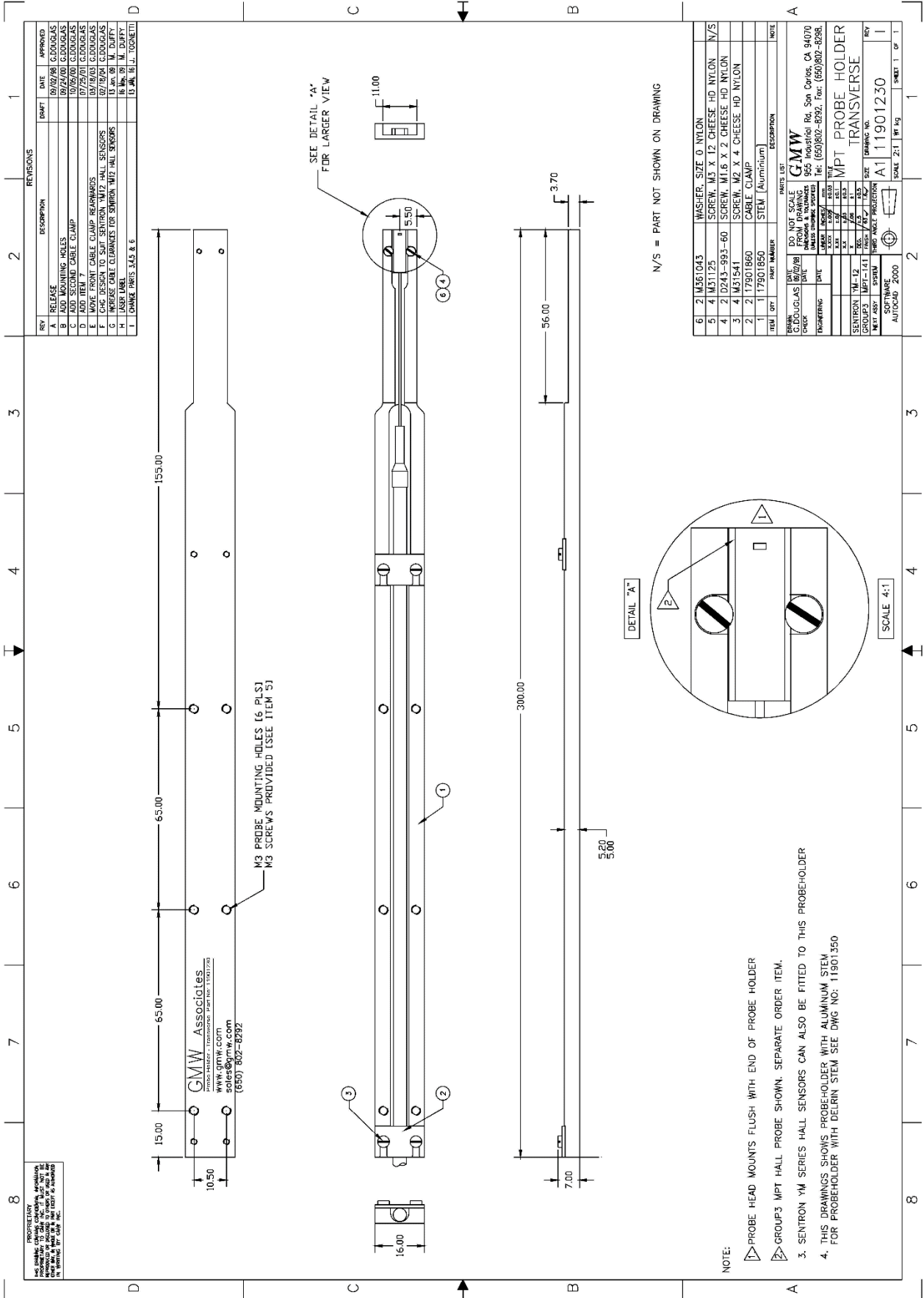

11.3.4 Drawing 11906-0000-0 A MPT Probe Holder Assy Transverse Machinable Garolite

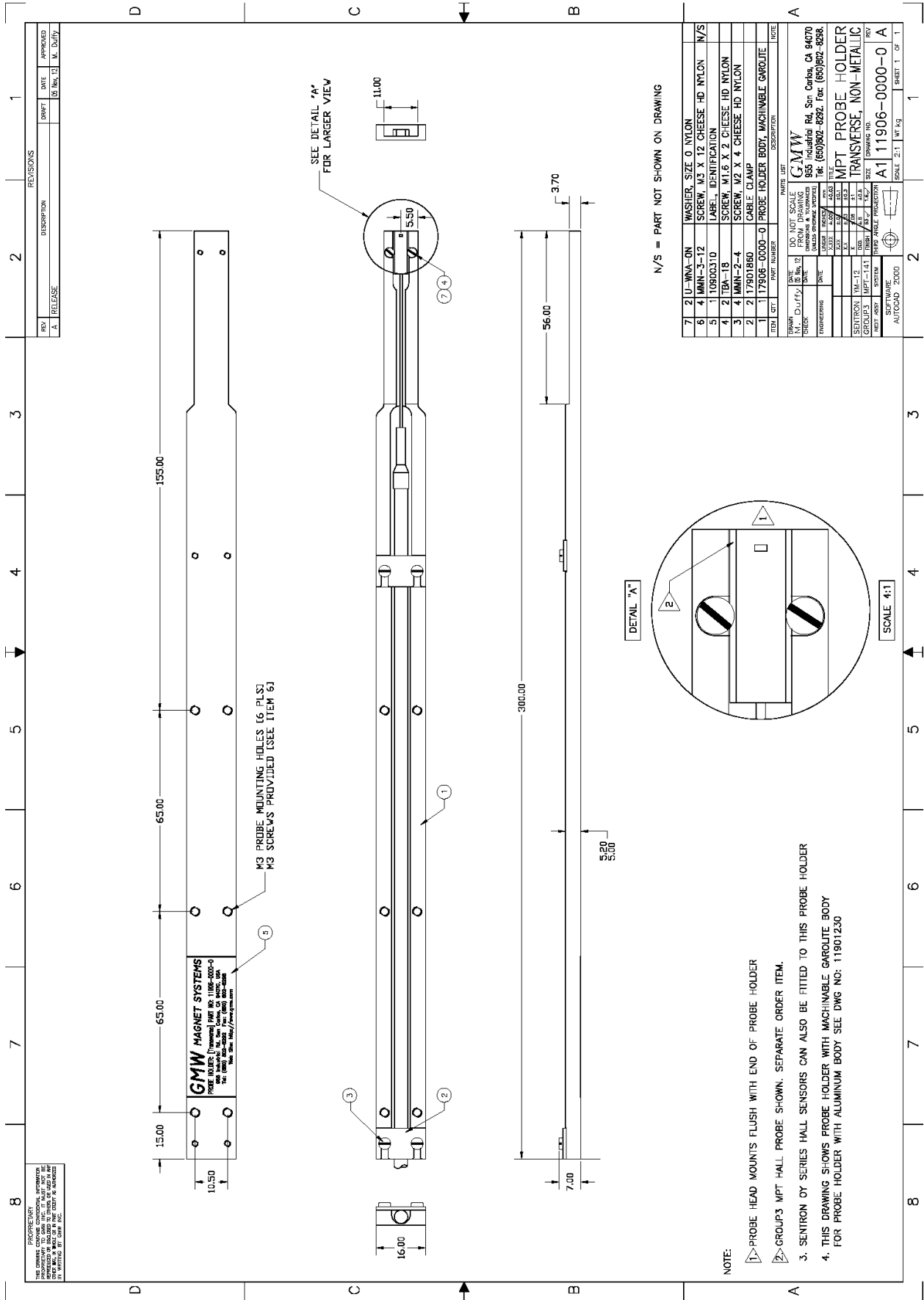

REVISIONS			
REV	DESCRIPTION	DATE	APPROVED
A	RELEASE	05 Nov 01	M. Duffy

N/S = PART NOT SHOWN ON DRAWING

ITEM	QTY	PART NUMBER	DESCRIPTION	UNIT
7	2	U-WNA-ON	WASHER, SIZE 0 NYLON	
6	4	MNH-3-12	SCREW M3 X 12 CHEESE HD NYLON	M/S
5	1	10900310	LABEL IDENTIFICATION	
4	2	TBA-18	SCREW M1.6 X 2 CHEESE HD NYLON	
3	4	MNH-3-4	SCREW M2 X 4 CHEESE HD NYLON	
2	2	17801860	CABLE CLAMP	
1	1	11906-0000-0	PROBE HOLDER BODY, MACHINABLE GAROLITE	

DATE	BY	DESCRIPTION
05 Nov 01	M. Duffy	RELEASE

DATE	BY	DESCRIPTION
05 Nov 01	M. Duffy	RELEASE

- NOTE:
- 1. PROBE HEAD MOUNTS FLUSH WITH END OF PROBE HOLDER
 - 2. GROUP3 MPT HALL PROBE SHOWN, SEPARATE ORDER ITEM.
 - 3. SENTRON DY SERIES HALL SENSORS CAN ALSO BE FITTED TO THIS PROBE HOLDER
 - 4. THIS DRAWING SHOWS PROBE HOLDER WITH MACHINABLE GAROLITE BODY FOR PROBE HOLDER WITH ALUMINUM BODY SEE DWG NO: 11901230

11.3.5 Drawing 11900330 3474 Pole Spacer Assembly

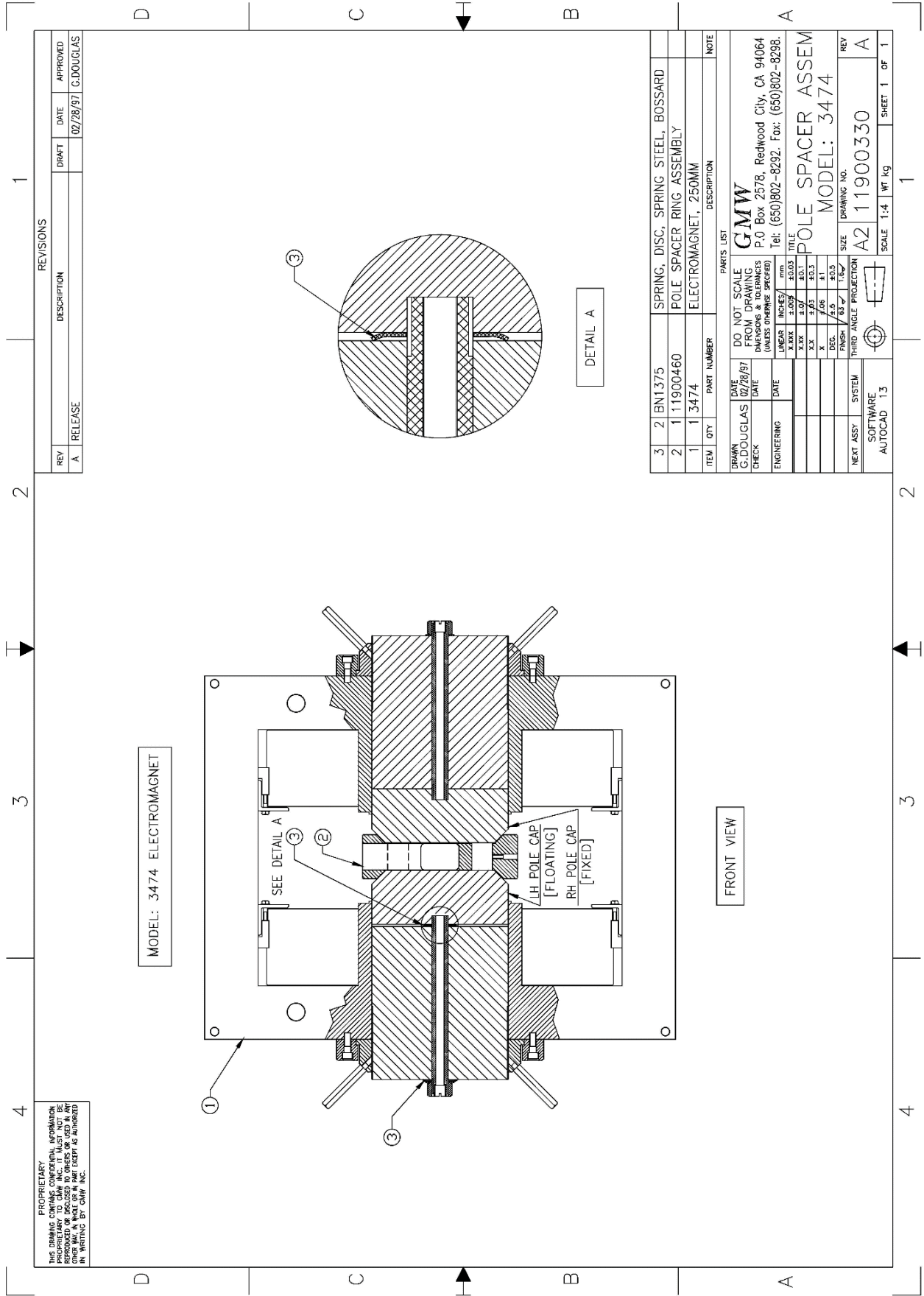

11.3.6 Drawing 11900461 3474 Pole Spacer

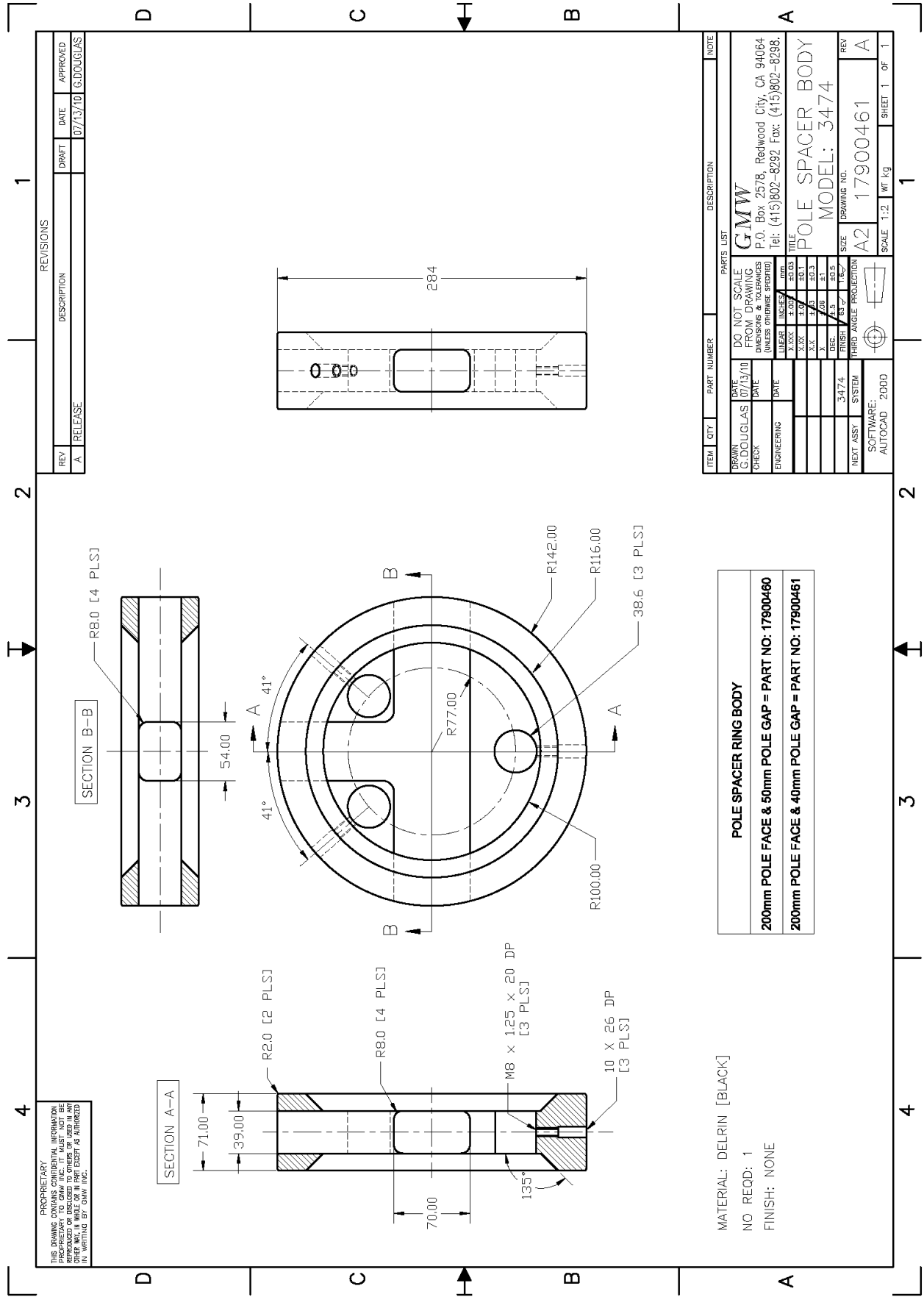

REVISIONS		DESCRIPTION	DATE	APPROVED
REV	A	RELEASE	07/13/10	G. DOUGLAS

ITEM	QTY	PART NUMBER	DESCRIPTION	NOTE
GMW DO NOT SCALE FROM DRAWING DIMENSIONS & TOLERANCES (UNLESS OTHERWISE SPECIFIED) P.O. Box 2578, Redwood City, CA 94064 Tel: (415)802-8292 Fax: (415)802-8298.				
POLE SPACER BODY MODEL: 3474				
TITLE: POLE SPACER BODY DRAWING NO.: 17900461 SCALE: 1:2 Wt kg SHEET 1 OF 1				

POLE SPACER RING BODY

200mm POLE FACE & 50mm POLE GAP = PART NO: 17900460

200mm POLE FACE & 40mm POLE GAP = PART NO: 17900461

MATERIAL: DELRIN [BLACK]
 NO REQD: 1
 FINISH: NONE

PROPRIETARY
 THIS DRAWING CONTAINS PROPRIETARY TO GMW, INC. IT MUST NOT BE REPRODUCED OR DISCLOSED TO OTHERS OR USED IN ANY MANNER WITHOUT THE WRITTEN CONSENT OF GMW, INC.

11.3.7 Drawing 17900691 3474 Pole Spacer Assembly

REVISIONS	
REV	APPROVED
A	07/13/10 G.DOUGLAS
DESCRIPTION	
DRAFT	

PROPRIETARY
THIS DRAWING CONTAINS CONFIDENTIAL INFORMATION PROPRIETARY TO GMW INC. IT MUST NOT BE REPRODUCED OR DISCLOSED TO OTHERS OR USED IN ANY OTHER WAY, IN WHOLE OR IN PART EXCEPT AS AUTHORIZED IN WRITING BY GMW INC.

LAP 3 POLE PIECES TO EQUAL LENGTH ± 0.001mm

MATERIAL: ALUMINA ROD 1.5" [38,1mm]
 NO REQD: 3
 FINISH: NONE

NOTE: BREAK ALL SHARP EDGES 0.2mm

PARTS LIST	
DO NOT SCALE FROM DRAWING DIMENSIONS & TOLERANCES (UNLESS OTHERWISE SPECIFIED)	GMW 955 Industrial Rd, San Carlos, CA 94070 Tel: (650)802-8292. Fax: (650)802-8298.
LINEAR X.XXX ±0.03 X.XX ±0.1 X.X ±0.3 X ±0.6 DEC. ±0.5	INCHES ±0.03 ±0.1 ±0.3 ±1 ±0.5
FINISH 83 ✓ 1.6 ✓	TITLE POLE SPACERS MODEL: 3474
SYSTEM AUTOCAD 2000	DRAWING NO. A3 17900691
SOFTWARE AUTOCAD 2000	SCALE 1:1 WT kg SHEET 1 OF 1

11.4 Modulation & Biasing Coils

11.4.1 Drawing 11207-0031-0 5494 Modulation Coil RH

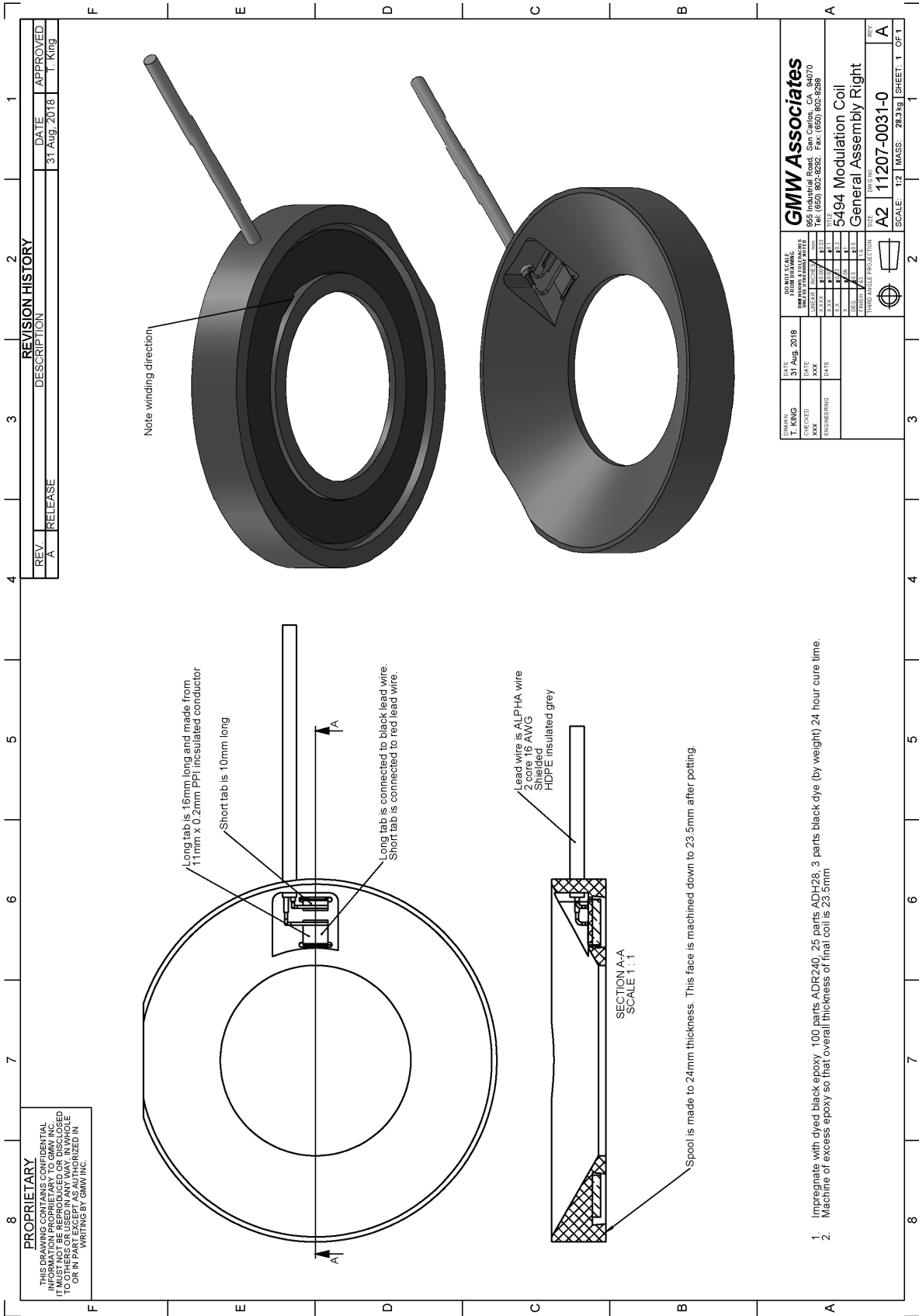

REVISION HISTORY		DATE	APPROVED
REV. A	RELEASE	31 Aug. 2018	T. King

PROPRIETARY
 THIS DRAWING CONTAINS CONFIDENTIAL INFORMATION PROPRIETARY TO GMW INC. IT MUST NOT BE REPRODUCED OR DISCLOSED TO ANY OTHER PARTY WITHOUT THE WRITING BY GMW INC.

REV. NO.	DATE	DESCRIPTION	BY	APP. BY
1	31 Aug. 2018	RELEASE	T. King	

DESIGNED	DATE	31 Aug. 2018	APPROVED	DATE	31 Aug. 2018
CHKD	DATE		CHKD	DATE	
ENGR'G	DATE		ENGR'G	DATE	

FORMING	DATE		FORMING	DATE	
FINISH	DATE		FINISH	DATE	

REV. NO.	DATE	DESCRIPTION	BY	APP. BY
A2	11207-0031-0	General Assembly Right		

SCALE	1:2	MASS	28.3kg	SHEET	1	OF	1
-------	-----	------	--------	-------	---	----	---

1. Impregnate with dyed black epoxy 100 parts ADR240, 25 parts ADH28, 3 parts black dye (by weight) 24 hour cure time.
2. Machine of excess epoxy so that overall thickness of final coil is 23.5mm

11.4.3 Drawing 11901481 3474 Bias Coil Assembly - LH

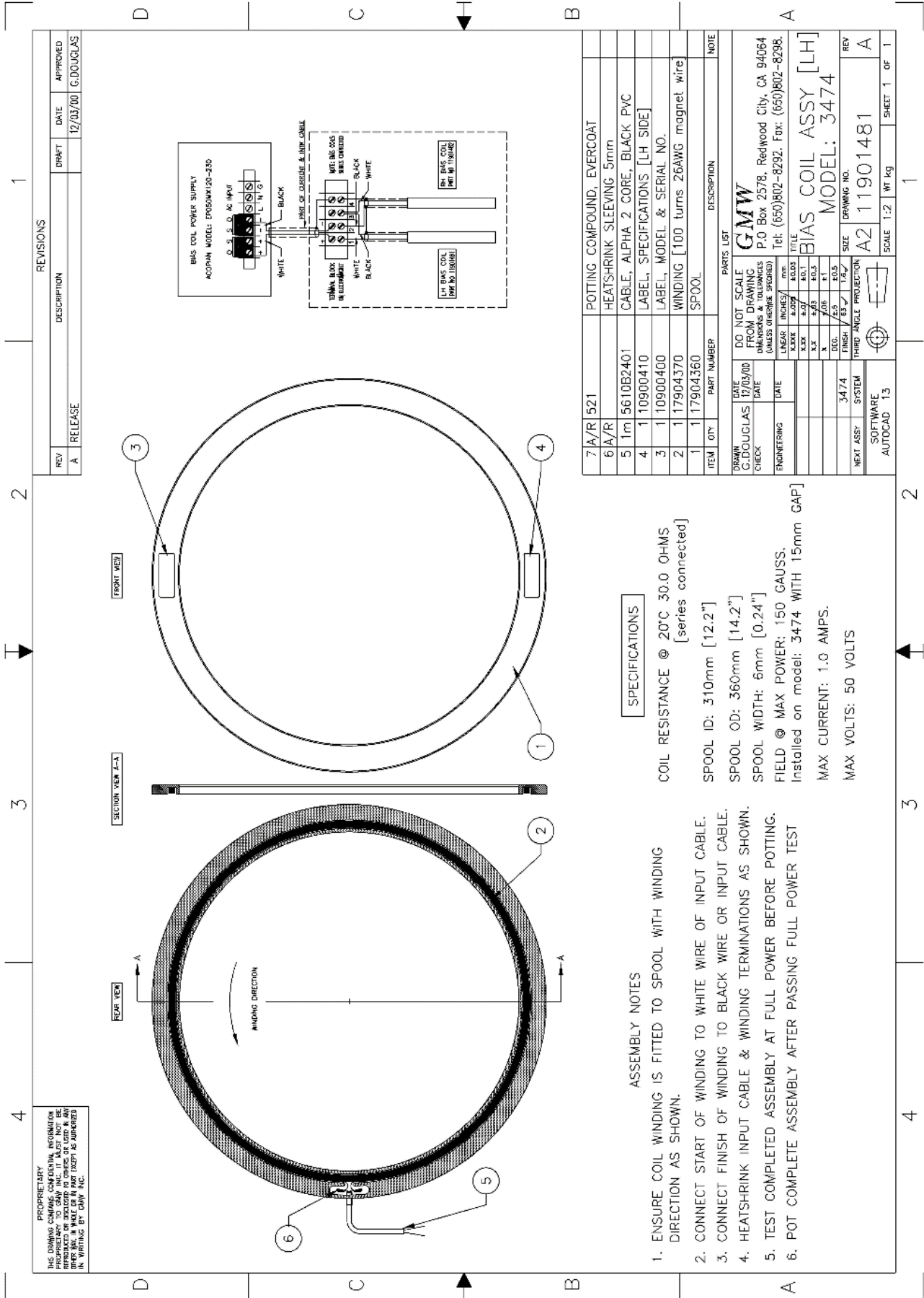

PROPRIETARY
THIS DRAWING CONTAINS CONFIDENTIAL INFORMATION
PREPARED BY OR FOR GMW INC. IT IS NOT TO BE
REPRODUCED OR DISCLOSED TO OTHERS OR USED IN ANY
MANNER WITHOUT THE WRITTEN CONSENT OF GMW INC.

ASSEMBLY NOTES

1. ENSURE COIL WINDING IS FITTED TO SPOOL WITH WINDING DIRECTION AS SHOWN.

2. CONNECT START OF WINDING TO WHITE WIRE OF INPUT CABLE.

3. CONNECT FINISH OF WINDING TO BLACK WIRE OR INPUT CABLE.

4. HEATSHRINK INPUT CABLE & WINDING TERMINATIONS AS SHOWN.

5. TEST COMPLETED ASSEMBLY AT FULL POWER BEFORE POTTING.

6. POT COMPLETE ASSEMBLY AFTER PASSING FULL POWER TEST

SPECIFICATIONS

COIL RESISTANCE @ 20°C 30.0 OHMS
[series connected]

SPOOL ID: 310mm [12.2"]

SPOOL OD: 360mm [14.2"]

SPOOL WIDTH: 6mm [0.24"]

FIELD @ MAX POWER: 150 GAUSS.

Installed on model: 3474 WITH 15mm GAP]

MAX CURRENT: 1.0 AMPS.

MAX VOLTS: 50 VOLTS

MAX CURRENT: 1.0 AMPS.

MAX VOLTS: 50 VOLTS

REV	DESCRIPTION	DRAFT	DATE	APPROVED
A	RELEASE		12/03/00	C. DOUGLAS

ITEM	QTY	PART NUMBER	DESCRIPTION	NOTE
7 A/R	521		POTTING COMPOUND, EVERCOAT	
6 A/R			HEATSHRINK SLEEVING, 5mm	
5	1m	5610B2401	CABLE, ALPHA 2 CORE, BLACK PVC	
4	1	10900410	LABEL, SPECIFICATIONS [LH SIDE]	
3	1	10900400	LABEL, MODEL & SERIAL NO.	
2	1	17904370	WINDING [100 turns 26AWG magnet wire]	
1	1	17904360	SPOOL	

DRAWN		DATE		PARTS LIST	
C. DOUGLAS	12/03/00	DO NOT SCALE	FROM DRAWING	GMW	
		UNLESS OTHERWISE SPECIFIED	UNLESS OTHERWISE SPECIFIED	P.O. Box 2578, Redwood City, CA 94064	
				Tel: (650)802-8292. Fax: (650)802-8298.	
				BIAS COIL ASSY [LH]	
				MODEL: 3474	
				DRAWING NO. A2 11901481	
				REV A	
				SCALE 1:2	
				WT kg	
				SHEET 1 OF 1	

11.5 Magnet Mounting

11.5.1 Drawing 11900480 45° Mounting Sequence

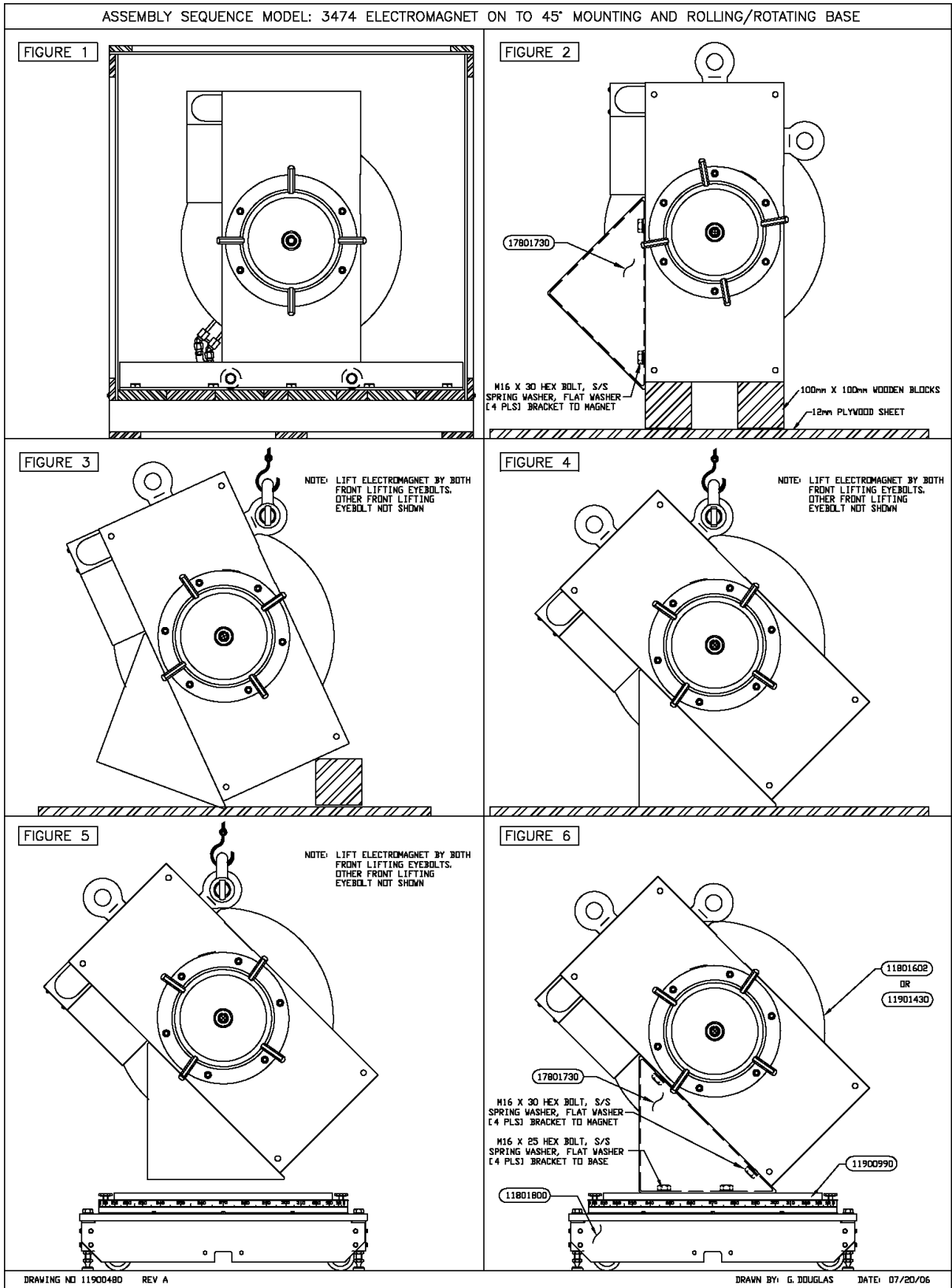

11.5.2 Mounting Brackets

11.5.2.1 Drawing 17801730 45° Mounting Brackets

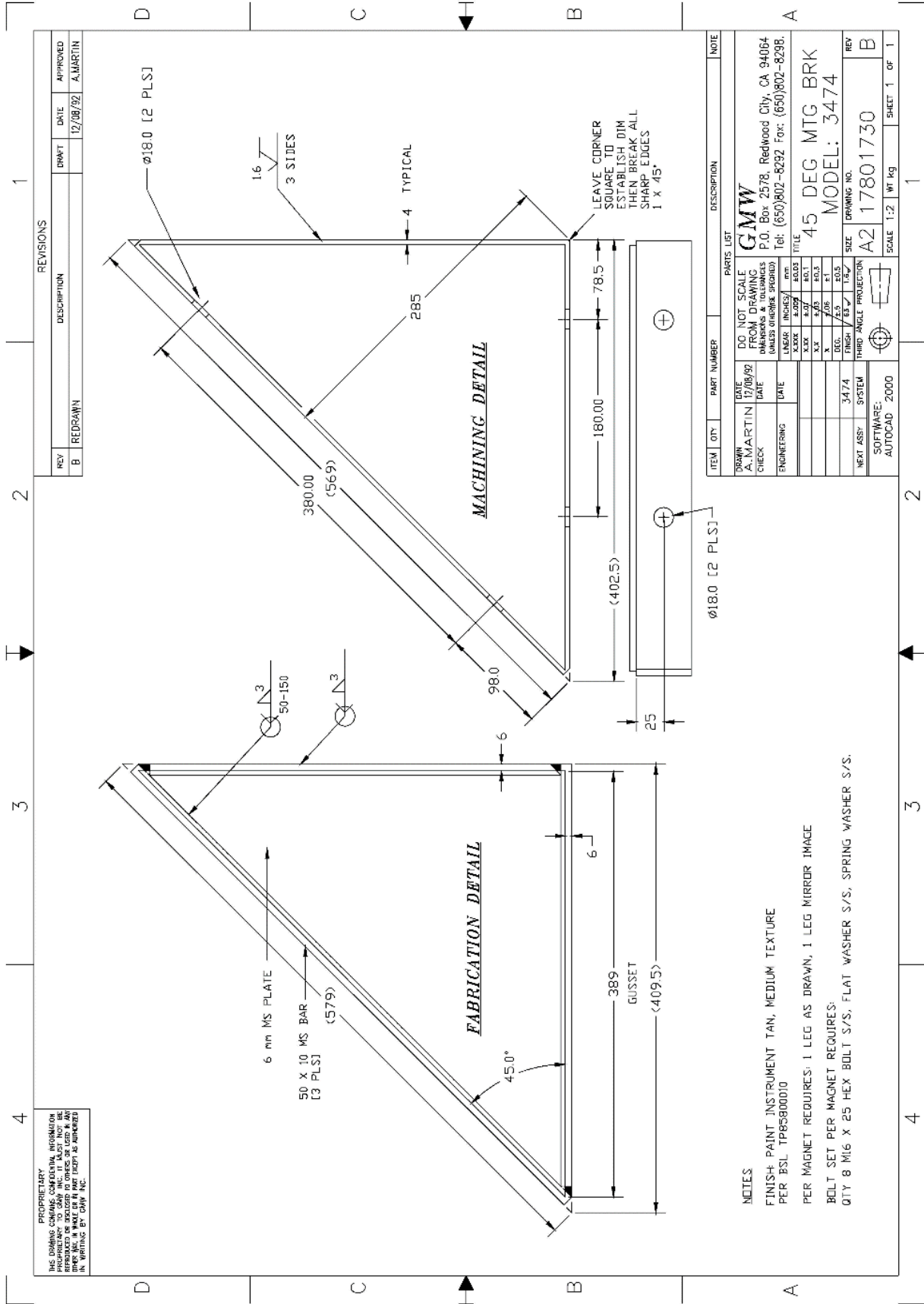

11.5.2.2 Drawing 17802690 Vertical Mounting Bracket

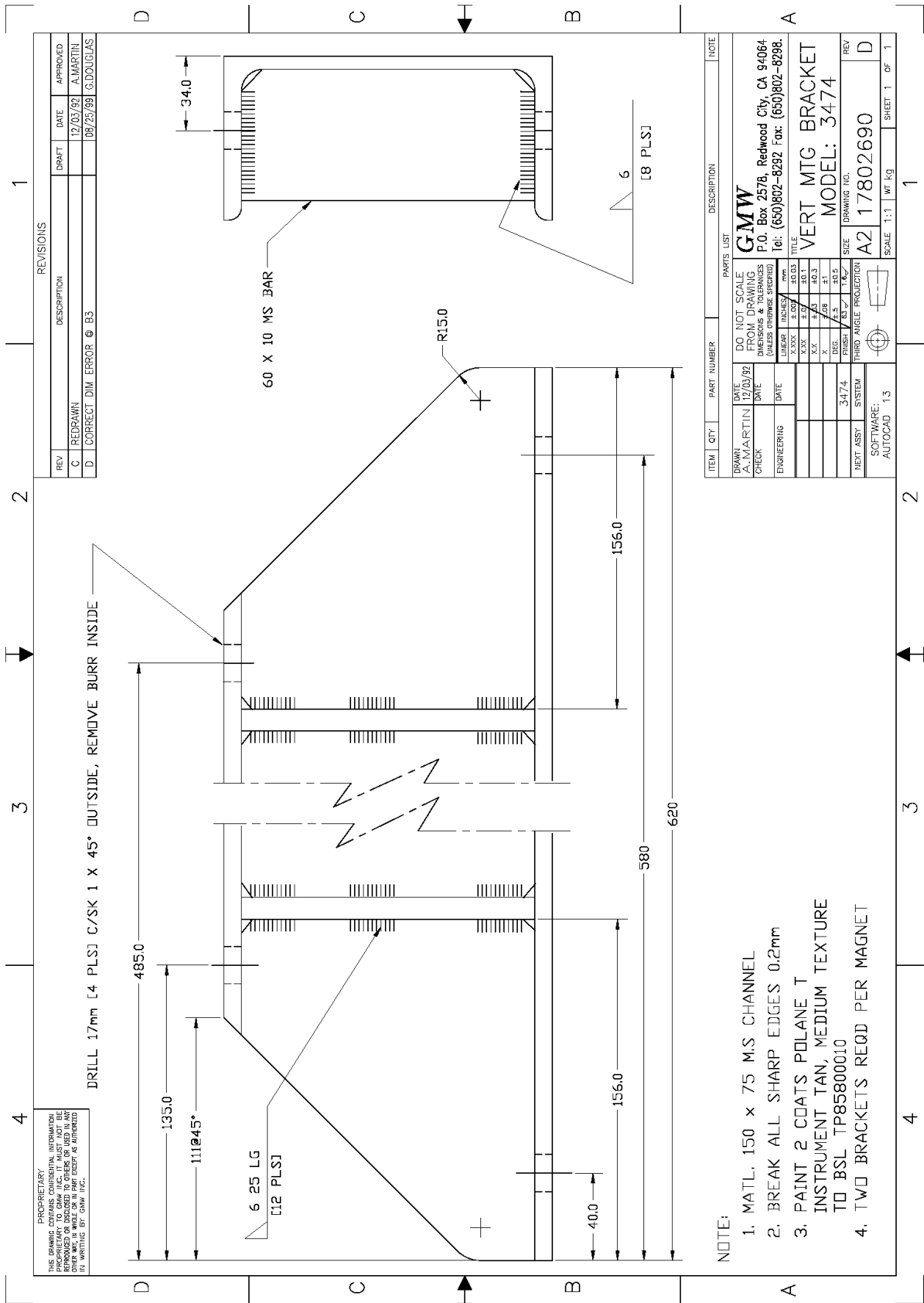

REVISIONS				
REV	DESCRIPTION	DRAFT	DATE	APPROVED
C	REDRAWN		12/03/92	A.MARTIN
D	CORRECT DIM. ERROR @ B3		08/25/99	G.DOUGLAS

ITEM	QTY	PART NUMBER	DESCRIPTION	NOTE																																																																						
<table border="1"> <tr> <td colspan="2">DRAWN: A.MARTIN</td> <td>DATE: 12/03/92</td> <td colspan="2">PARTS LIST</td> </tr> <tr> <td colspan="2">CHECK:</td> <td>DATE:</td> <td colspan="2">DO NOT SCALE FROM DRAWING</td> </tr> <tr> <td colspan="2">ENGINEERS:</td> <td>DATE:</td> <td colspan="2">DIMENSIONS & TOLERANCES (UNLESS OTHERWISE SPECIFIED)</td> </tr> <tr> <td></td> <td></td> <td></td> <td>LINEAR</td> <td>INCHES / mm</td> </tr> <tr> <td></td> <td></td> <td></td> <td>X-XXX</td> <td>±.009 / ±0.03</td> </tr> <tr> <td></td> <td></td> <td></td> <td>X-X</td> <td>±.007 / ±0.1</td> </tr> <tr> <td></td> <td></td> <td></td> <td>X-X</td> <td>±.05 / ±0.3</td> </tr> <tr> <td></td> <td></td> <td></td> <td>DEG.</td> <td>±.5 / ±0.5</td> </tr> <tr> <td></td> <td></td> <td></td> <td>FINISH</td> <td>63 / 1.6</td> </tr> <tr> <td></td> <td></td> <td></td> <td>SIZE</td> <td>34.74</td> </tr> <tr> <td></td> <td></td> <td></td> <td>SYSTEM</td> <td></td> </tr> <tr> <td></td> <td></td> <td></td> <td>THIRD ANGLE PROJECTION</td> <td></td> </tr> <tr> <td></td> <td></td> <td></td> <td>SOFTWARE:</td> <td></td> </tr> <tr> <td></td> <td></td> <td></td> <td>AUTOCAD</td> <td>13</td> </tr> </table>					DRAWN: A.MARTIN		DATE: 12/03/92	PARTS LIST		CHECK:		DATE:	DO NOT SCALE FROM DRAWING		ENGINEERS:		DATE:	DIMENSIONS & TOLERANCES (UNLESS OTHERWISE SPECIFIED)					LINEAR	INCHES / mm				X-XXX	±.009 / ±0.03				X-X	±.007 / ±0.1				X-X	±.05 / ±0.3				DEG.	±.5 / ±0.5				FINISH	63 / 1.6				SIZE	34.74				SYSTEM					THIRD ANGLE PROJECTION					SOFTWARE:					AUTOCAD	13
DRAWN: A.MARTIN		DATE: 12/03/92	PARTS LIST																																																																							
CHECK:		DATE:	DO NOT SCALE FROM DRAWING																																																																							
ENGINEERS:		DATE:	DIMENSIONS & TOLERANCES (UNLESS OTHERWISE SPECIFIED)																																																																							
			LINEAR	INCHES / mm																																																																						
			X-XXX	±.009 / ±0.03																																																																						
			X-X	±.007 / ±0.1																																																																						
			X-X	±.05 / ±0.3																																																																						
			DEG.	±.5 / ±0.5																																																																						
			FINISH	63 / 1.6																																																																						
			SIZE	34.74																																																																						
			SYSTEM																																																																							
			THIRD ANGLE PROJECTION																																																																							
			SOFTWARE:																																																																							
			AUTOCAD	13																																																																						
			TITLE	VERT MTG BRACKET																																																																						
			MODEL:	3474																																																																						
			DRAWING NO.	A2 17802690																																																																						
			REV	D																																																																						
			SCALE	1:1																																																																						
			WT	kg																																																																						
			SHEET	1 OF 1																																																																						

- NOTE:
1. MATL. 150 x 75 M.S CHANNEL
 2. BREAK ALL SHARP EDGES 0.2mm
 3. PAINT 2 COATS POLANE T INSTRUMENT TAN, MEDIUM TEXTURE TO BSL TP85800010
 4. TWO BRACKETS REQD PER MAGNET

11.5.3.2 Drawing 11900990 Rotating Base Assembly

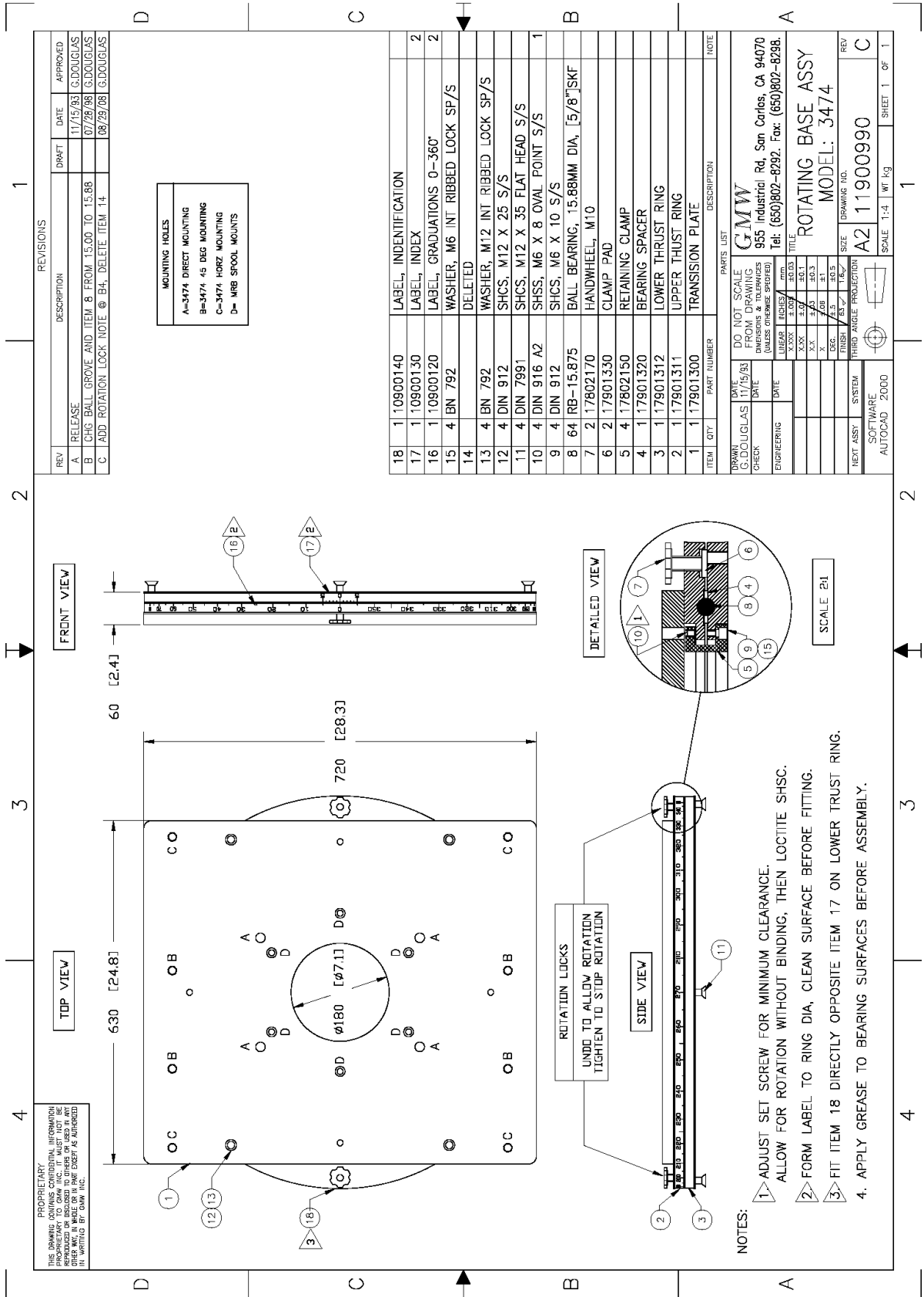

REV	DESCRIPTION	DRAFT	DATE	APPROVED
A	RELEASE		11/15/93	G.DOUGLAS
B	CHG BALL GROVE AND ITEM 8 FROM 15.00 TO 15.88		07/28/98	G.DOUGLAS
C	ADD ROTATION LOCK NOTE @ B4, DELETE ITEM 14		08/29/08	G.DOUGLAS

MOUNTING HOLES
 A=3474 DIRECT MOUNTING
 B=3474 45 DEG MOUNTING
 C=3474 HORIZ MOUNTING
 D= MRB SPOOL MOUNTS

ITEM	QTY	PART NUMBER	DESCRIPTION	NOTE
18	1	10900140	LABEL, IDENTIFICATION	
17	1	10900130	LABEL, INDEX	2
16	1	10900120	LABEL, GRADUATIONS 0-360°	2
15	4	BN 792	WASHER, M6 INT RIBBED LOCK SP/S	
14			DELETED	
13	4	BN 792	WASHER, M12 INT RIBBED LOCK SP/S	
12	4	DIN 912	SHCS, M12 X 25 S/S	
11	4	DIN 7991	SHCS, M12 X 35 FLAT HEAD S/S	
10	4	DIN 916 A2	SHSS, M6 X 8 OVAL POINT S/S	1
9	4	DIN 912	SHCS, M6 X 10 S/S	
8	64	RB-15.875	BALL BEARING, 15.88MM DIA, [5/8]SKF	
7	2	17802170	HANDWHEEL, M10	
6	2	17901330	CLAMP PAD	
5	4	17802150	RETAINING CLAMP	
4	1	17901320	BEARING SPACER	
3	1	17901312	LOWER THRUST RING	
2	1	17901311	UPPER THRUST RING	
1	1	17901300	TRANSITION PLATE	

CMW
 955 Industrial Rd, San Carlos, CA 94070
 Tel: (650)802-8292, Fax: (650)802-8298

ROTATING BASE ASSY
 MODEL: 3474

SCALE: 1:4 | WT. kg | SHEET 1 OF 1

SOFTWARE: AUTOCAD 2000

11.5.3.3 Drawing 11900980 Rolling & Rotating Base Assembly

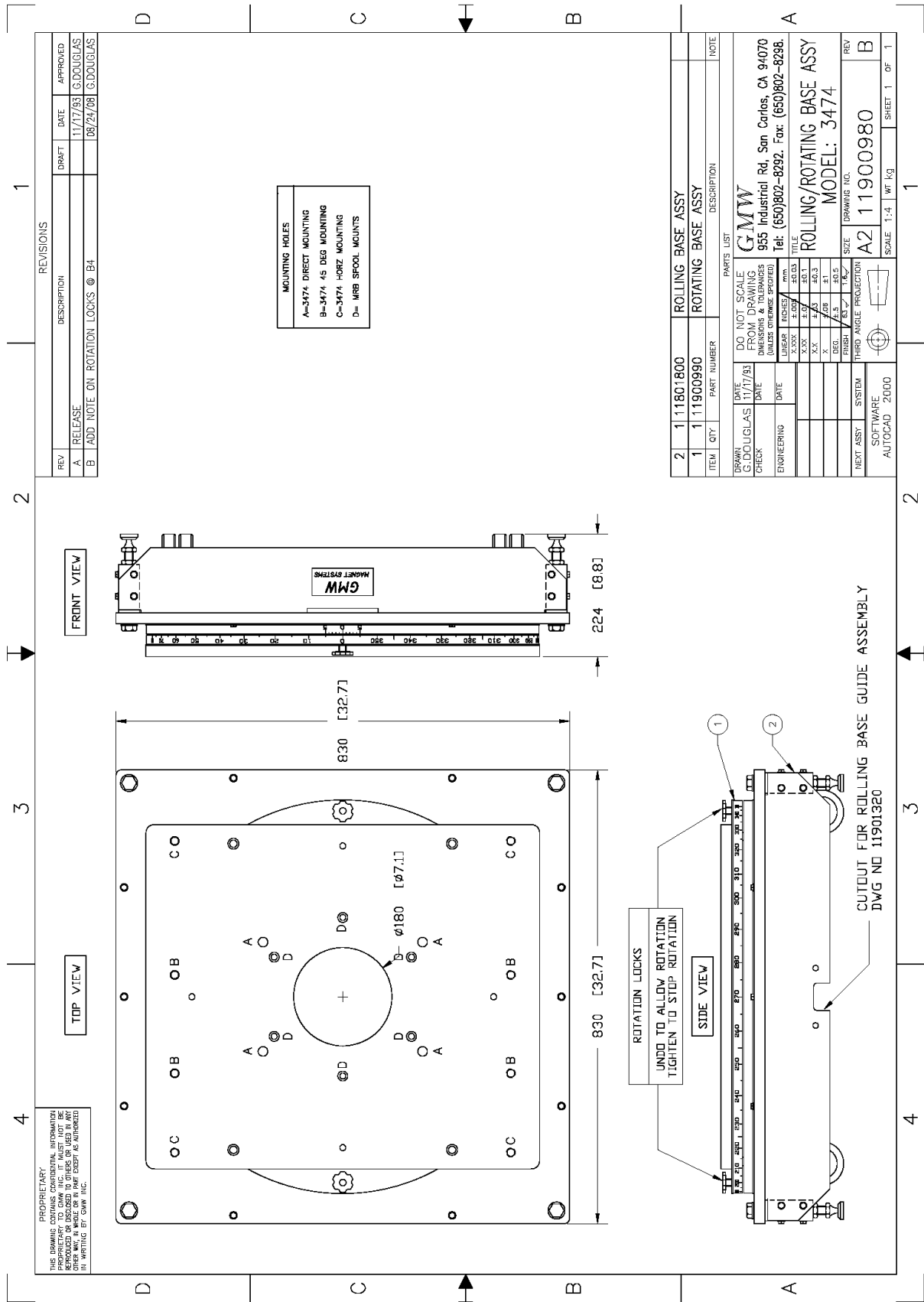

11.5.3.5 Drawing 11900940 45° Mounted on Rotating Base

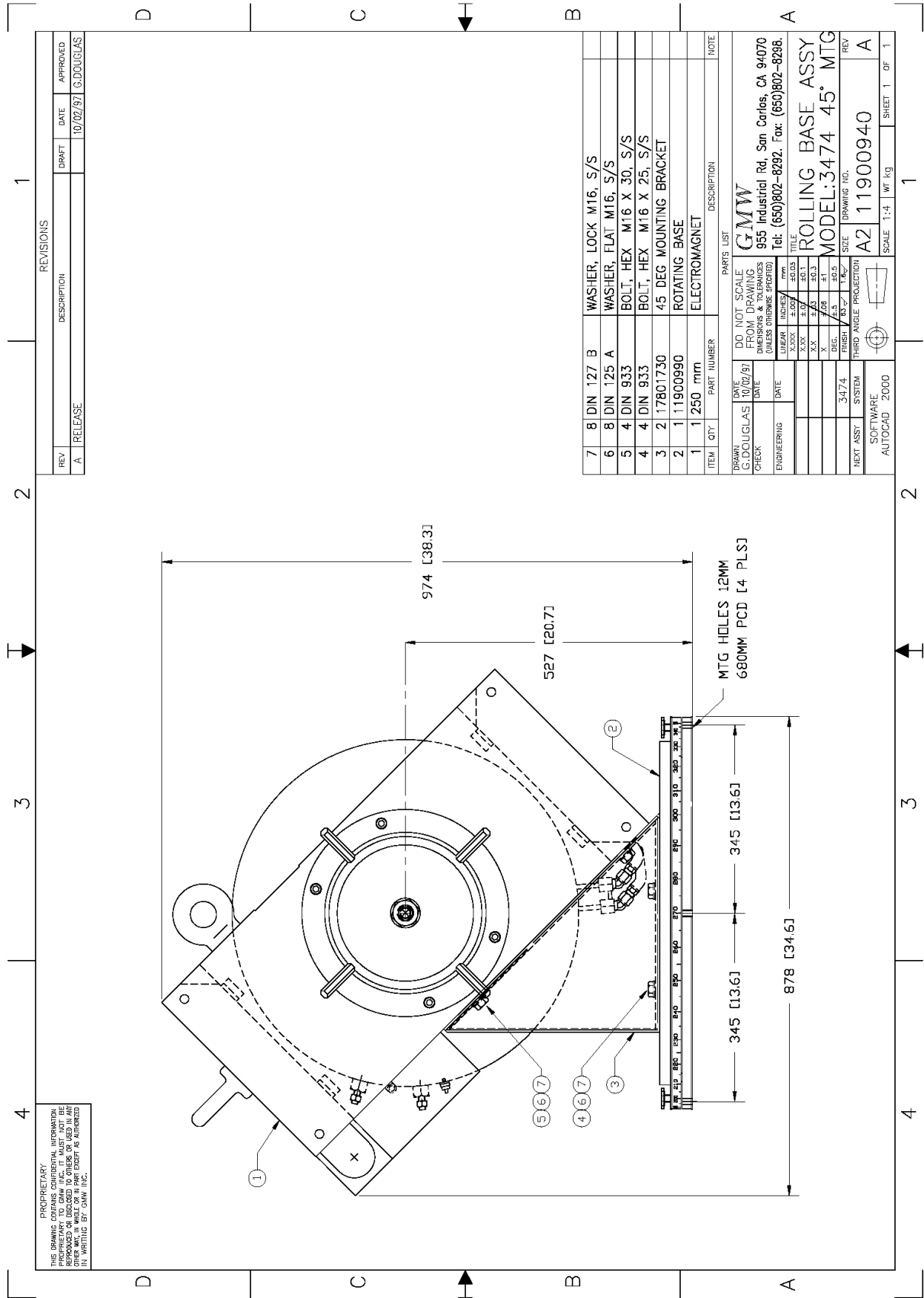

11.5.3.6 Drawing 11900690 45° Mounted on Rolling Base

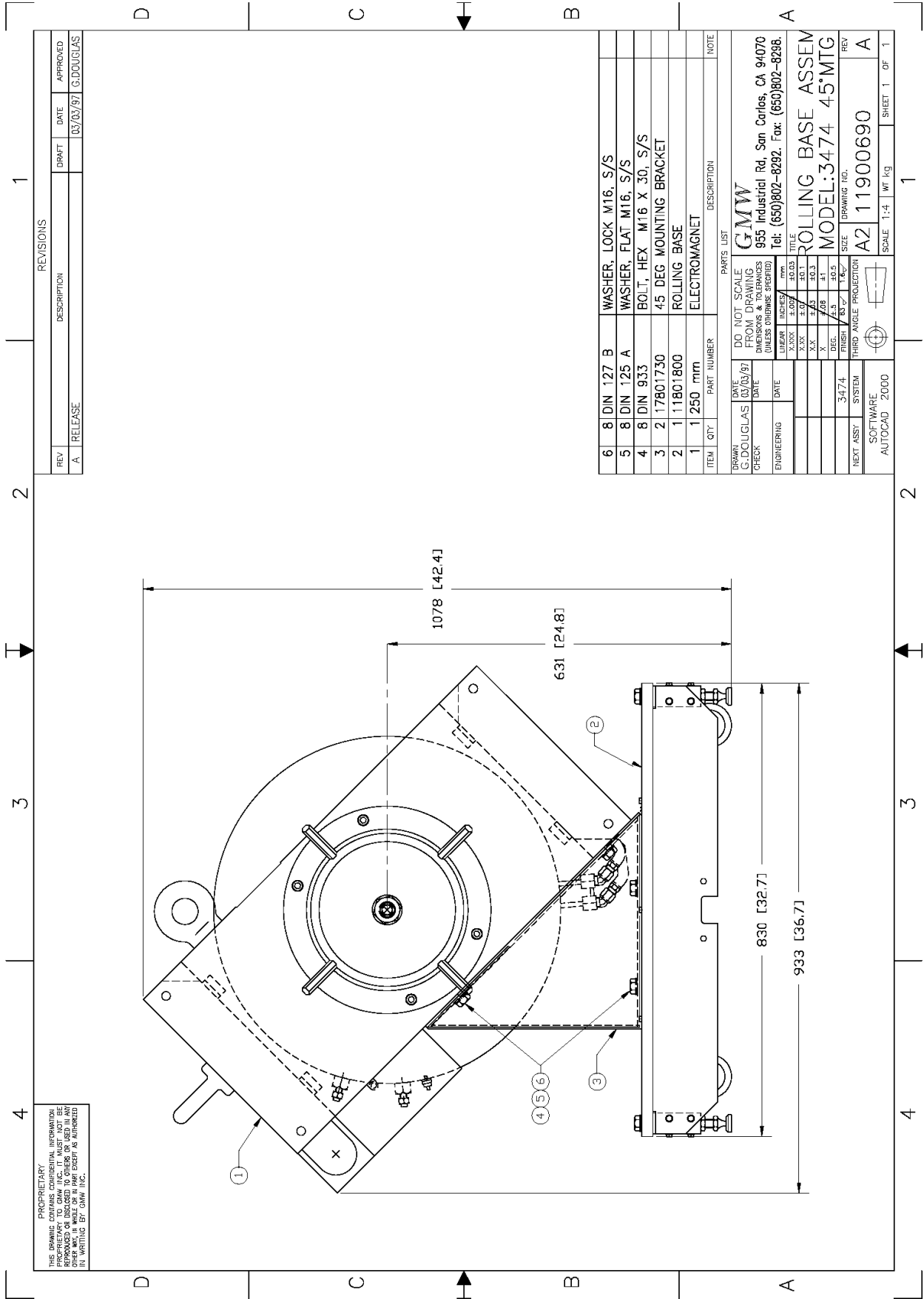

11.5.3.7 Drawing 11900930 45° Mounting on Rolling & Rotating Base

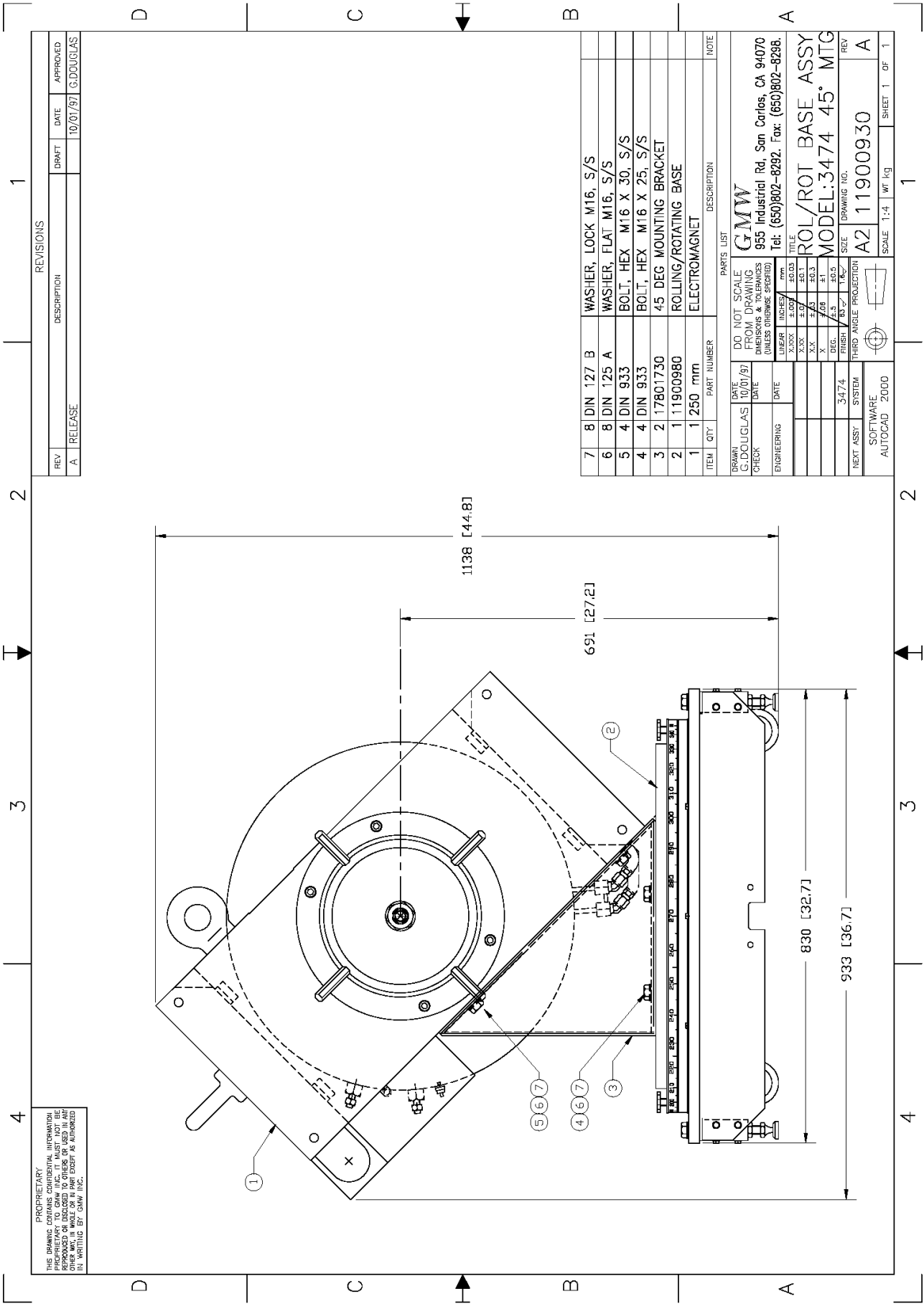

PROPRIETARY
 THIS DRAWING CONTAINS CONFIDENTIAL INFORMATION
 PROPRIETARY TO GMW INC. IT MUST NOT BE
 REPRODUCED OR TRANSMITTED IN ANY FORM OR
 OTHER MANNER, IN WHOLE OR IN PART EXCEPT AS AUTHORIZED
 IN WRITING BY GMW INC.

REVISIONS			
REV	DESCRIPTION	DATE	APPROVED
A	RELEASE	10/01/97	G.DOUGLAS

ITEM	QTY	PART NUMBER	DESCRIPTION	NOTE
7	8	DIN 127 B	WASHER, LOCK M16, S/S	
6	8	DIN 125 A	WASHER, FLAT M16, S/S	
5	4	DIN 933	BOLT, HEX M16 X 30, S/S	
4	4	DIN 933	BOLT, HEX M16 X 25, S/S	
3	2	17801730	45 DEG MOUNTING BRACKET	
2	1	11900980	ROLLING/ROTATING BASE	
1	1	250 mm	ELECTROMAGNET	

DO NOT SCALE FROM DIMENSIONS UNLESS OTHERWISE SPECIFIED

DATE: 10/01/97
 DRAWN: G.DOUGLAS
 CHECK: G.DOUGLAS
 ENGINEERING: G.DOUGLAS

GMW
 955 Industrial Rd, San Carlos, CA 94070
 Tel: (650)802-8292, Fax: (650)802-8298

ROLL/ROT BASE ASSY
 MODEL: 3474 45° MTG
 SIZE: 347.4
 THIRDS ANGLE PROJECTION

SOFTWARE: AUTOCAD 2000

SCALE: 1:4 WT: kg SHEET 1 OF 1

11.5.3.8 Drawing 11900970 Horizontal Mounting on Rotating Base

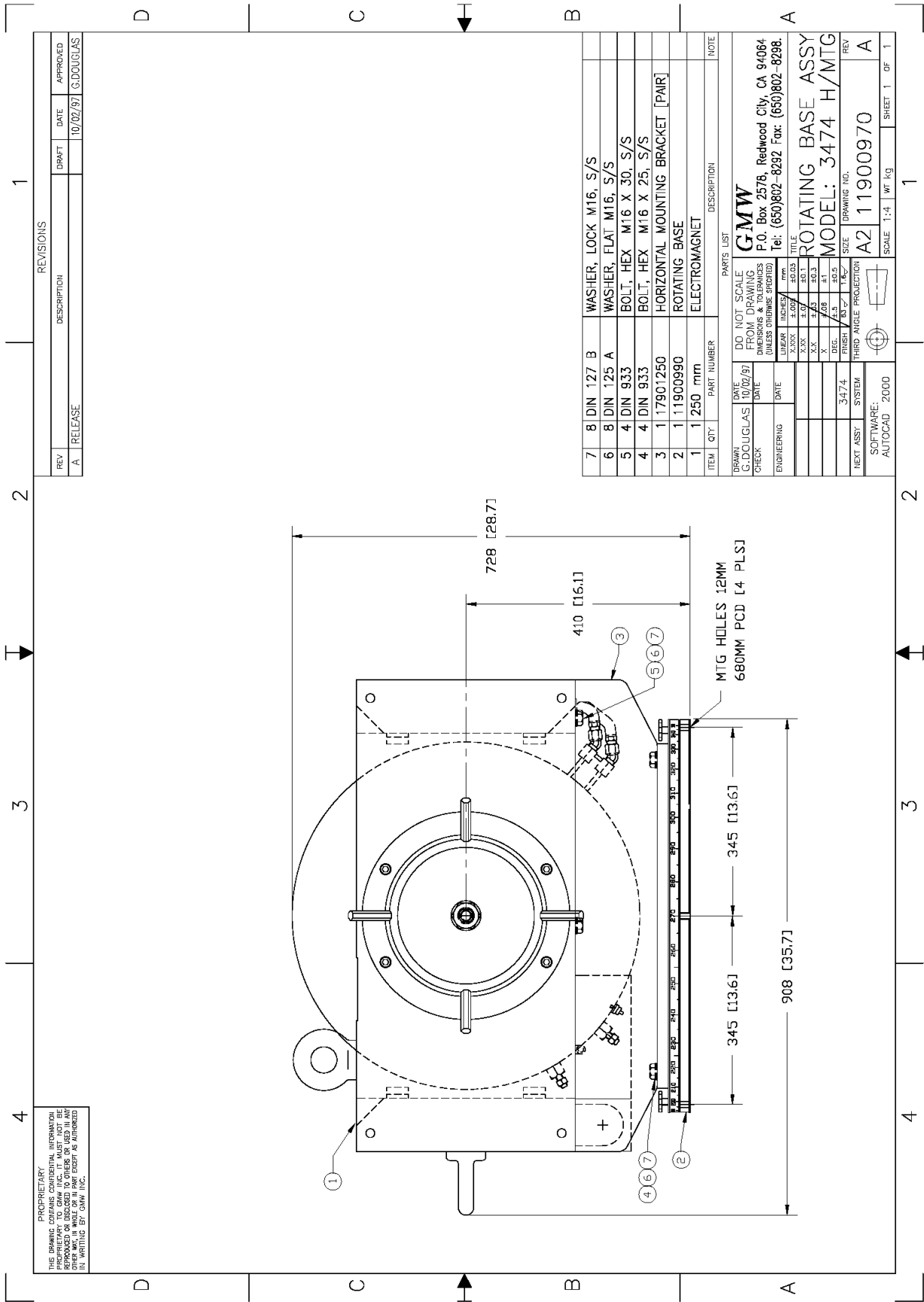

11.5.3.9 Drawing 11900960 Horizontal Mounting on Rolling Base

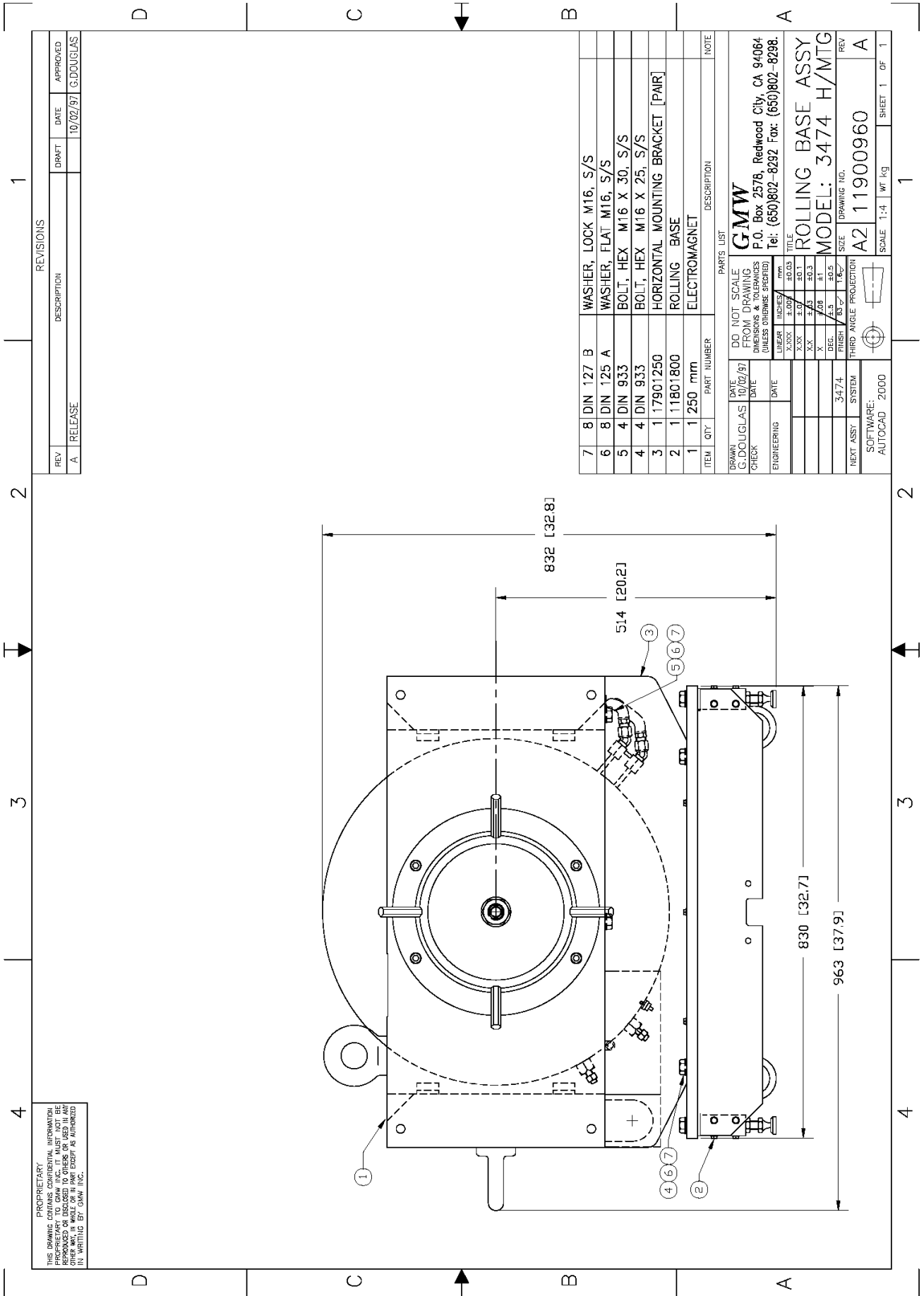

PROPRIETARY
 THIS DRAWING CONTAINS CONFIDENTIAL INFORMATION.
 ITS REPRODUCTION OR DISCLOSURE TO OTHERS WITHOUT THE
 EXPRESS WRITTEN PERMISSION OF GMW INC. IS PROHIBITED.
 OTHER THAN IN WRITING BY GMW INC.

REVISIONS			
REV	DESCRIPTION	DRAFT	DATE
A	RELEASE		10/02/97
			G.DOUGLAS

ITEM	QTY	PART NUMBER	DESCRIPTION	NOTE
7	8	DIN 127 B	WASHER, LOCK M16, S/S	
6	8	DIN 125 A	WASHER, FLAT M16, S/S	
5	4	DIN 933	BOLT, HEX M16 X 30, S/S	
4	4	DIN 933	BOLT, HEX M16 X 25, S/S	
3	1	117901250	HORIZONTAL MOUNTING BRACKET [PAIR]	
2	1	11801800	ROLLING BASE	
1	1	250 mm	ELECTROMAGNET	

PARTS LIST		TITLE	
DATE	10/02/97	DO NOT SCALE	ROLLING BASE ASSY
DRAWN	G.DOUGLAS	FROM DRAWING	MODEL: 3474 H/MTG
CHECK		DIMENSIONS & TOLERANCES	
ENGINEERING		(UNLESS OTHERWISE SPECIFIED)	
		LINEAR	INCHES
		X:XXX	±0.03
		X:XX	±0.1
		X:X	±0.3
		X	±1
		DEG.	±0.5
		FINISH	32-6Z
		THIRD ANGLE PROJECTION	
NEXT ASSY	SYSTEM	SIZE	DRAWING NO.
AUTOCAD	2000	A2	11900960
		SCALE	1:4
		WT	kg
			SHEET 1 OF 1

11.5.3.10 Drawing 11900950 Horizontal Mounting on Rolling & Rotating Base

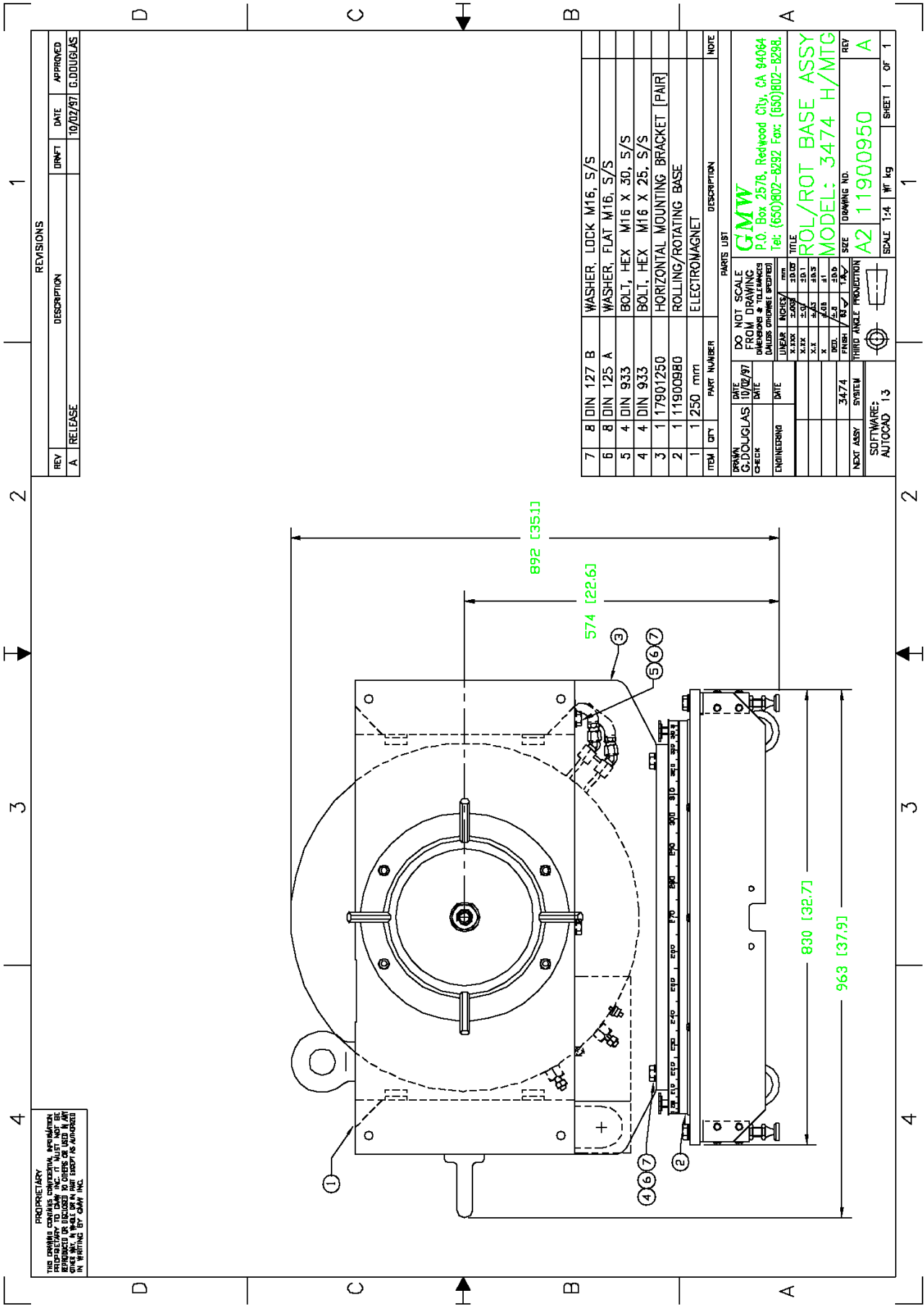

11.5.3.11 Drawing 11900801 Motorized Rotating Drive, Rolling Base

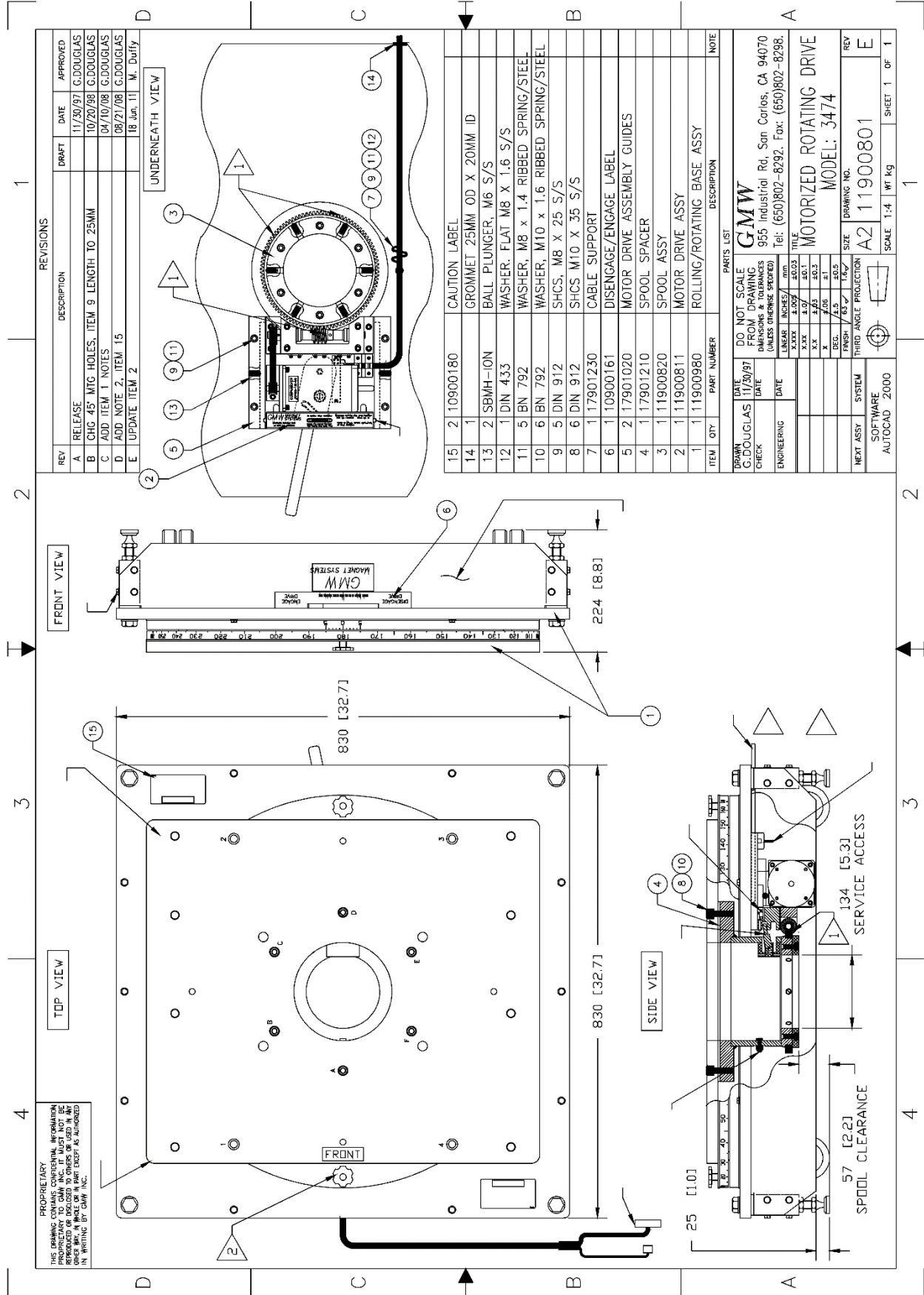

12. SHIPPING CRATES

12.1 Drawing 18800191 Shipping Crate Assembly

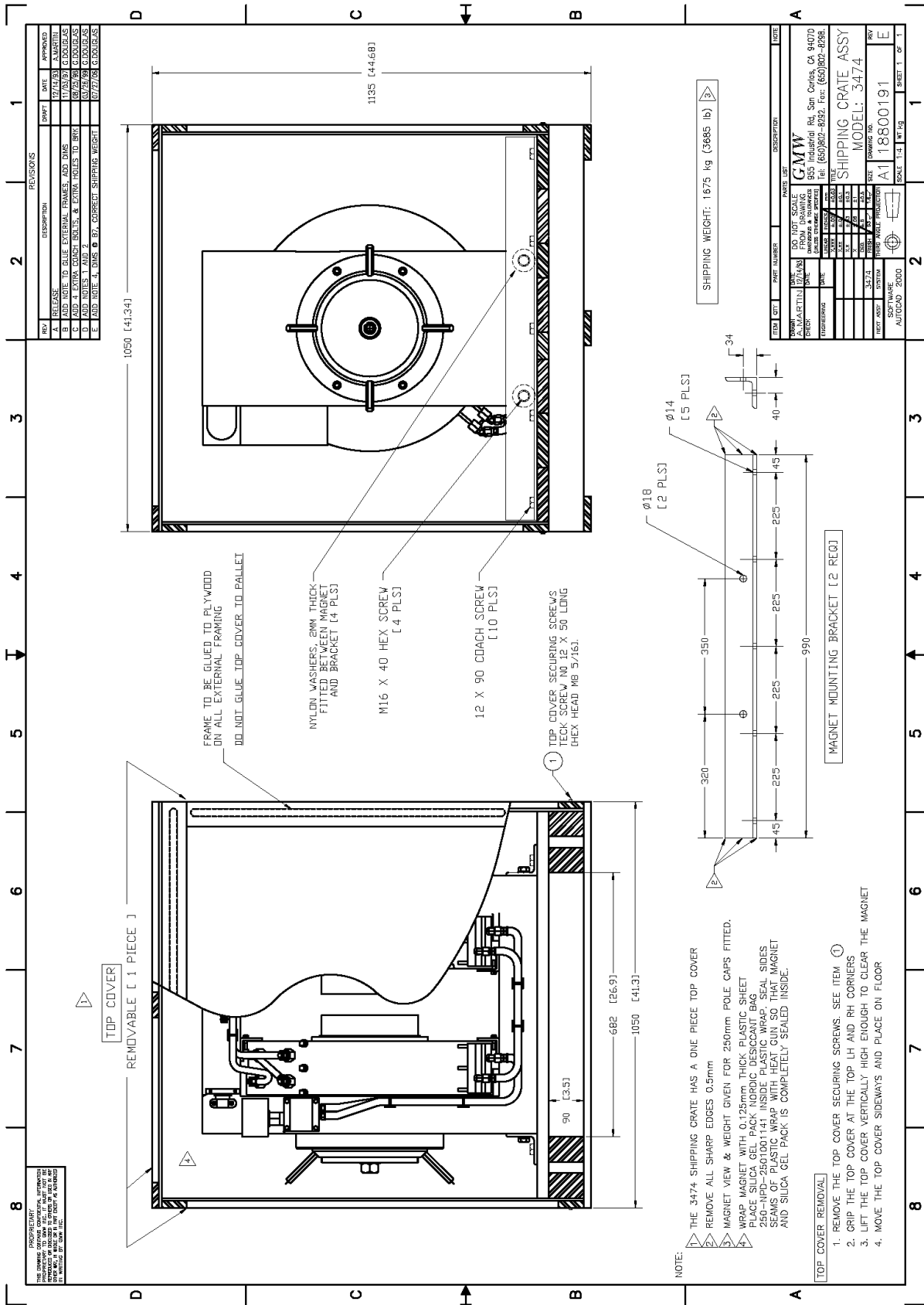

13. MAGNET DRAWINGS

13.1 Drawing 11801602 Variable Gap Magnet Assembly

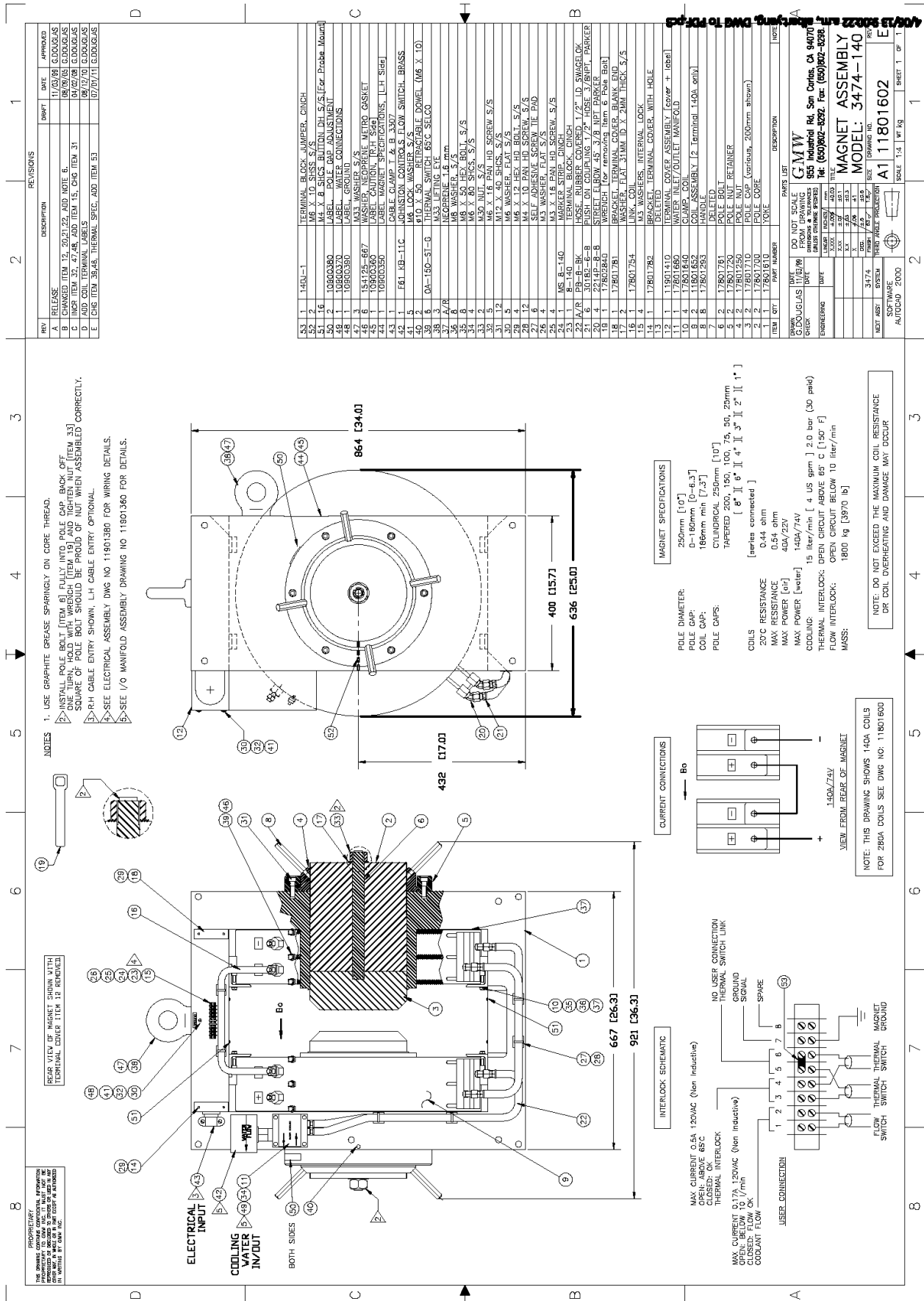

13.2 Drawing 11801603 Fixed Gap Magnet Assembly

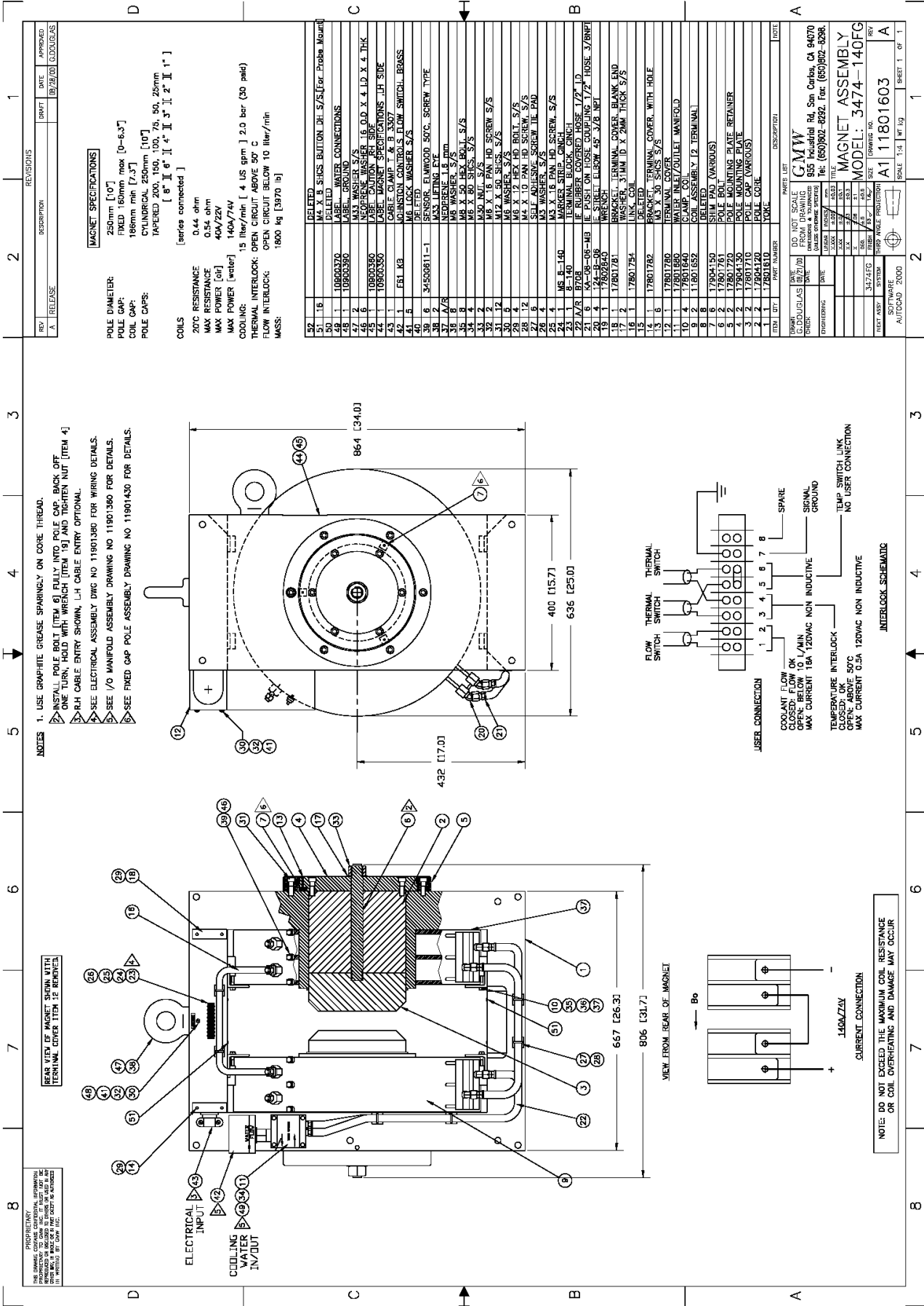

13.3 Drawing 11901360 In/Out Manifold Assembly

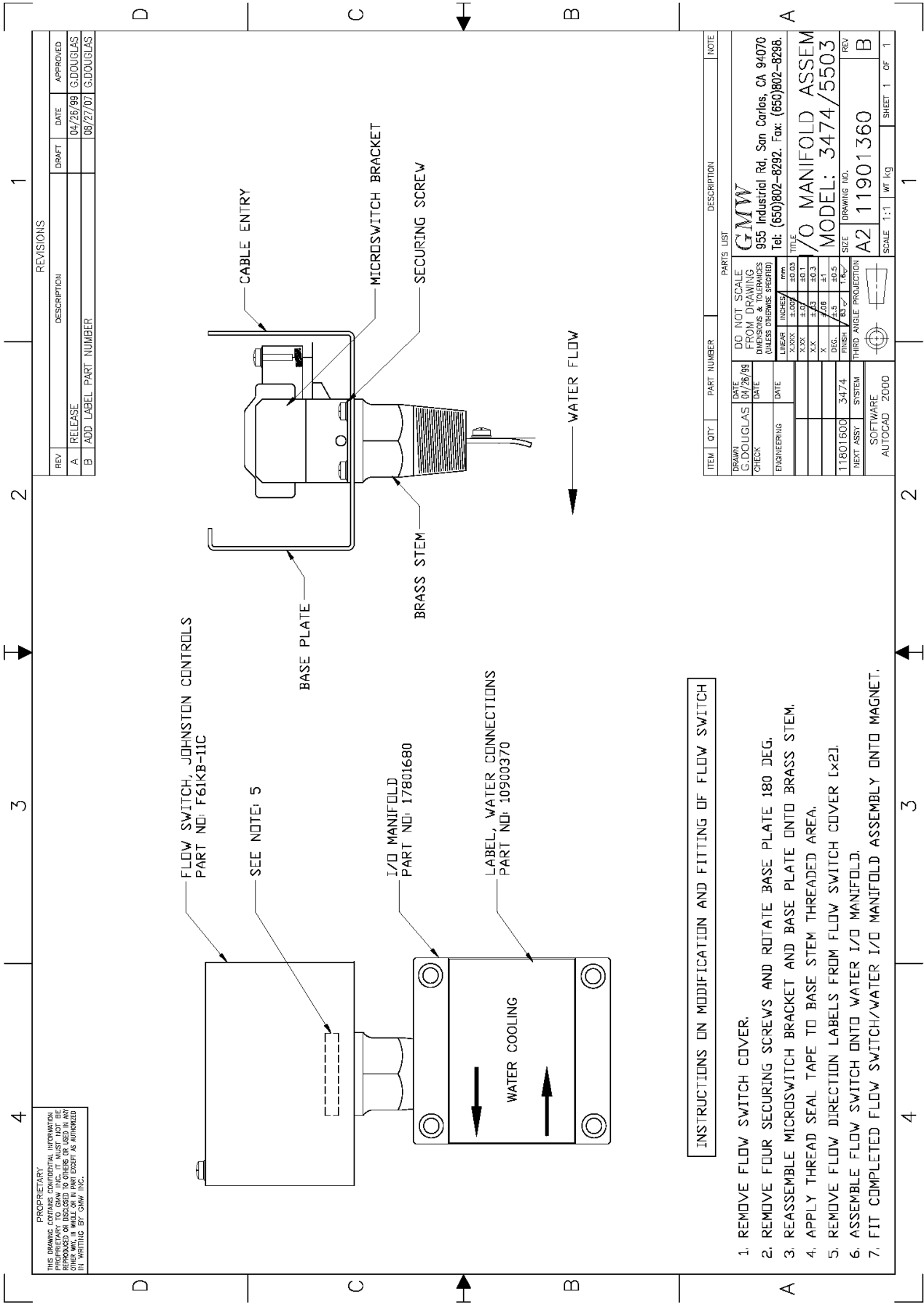

REVISIONS				
REV	DESCRIPTION	DRAFT	DATE	APPROVED
A	RELEASE		04/26/99	G.DOUGLAS
B	ADD LABEL PART NUMBER		08/27/07	G.DOUGLAS

ITEM	QTY	PART NUMBER	DESCRIPTION	NOTE
PARTS LIST				
DRAWN	DATE	DO NOT SCALE FROM DRAWING		
G.DOUGLAS	04/26/99	DIMENSIONS & TOLERANCES (UNLESS OTHERWISE SPECIFIED)		
CHECK	DATE	LINEAR	INCHES	MILL
		X-XXX	±.007	±0.03
		X-XX	±.01	±0.1
		X-X	±.02	±0.3
		X	±.05	±1
ENGINEERING	DATE	RADIUS	R	±.01
		ANG.	±.01	±.1
		THIRD ANGLE PROJECTION		
11801600	3474	TITLE		
		/O MANIFOLD ASSEM		
		MODEL: 3474/5503		
		SIZE	DRAWING HD.	REV
		A2	11901360	B
		SOFTWARE	SCALE: 1:1	WT. kg
		AUTOCAD 2000		SHEET 1 OF 1

INSTRUCTIONS ON MODIFICATION AND FITTING OF FLOW SWITCH

1. REMOVE FLOW SWITCH COVER.
2. REMOVE FOUR SECURING SCREWS AND ROTATE BASE PLATE 180 DEG.
3. REASSEMBLE MICROSWITCH BRACKET AND BASE PLATE ONTO BRASS STEM.
4. APPLY THREAD SEAL TAPE TO BASE STEM THREADED AREA.
5. REMOVE FLOW DIRECTION LABELS FROM FLOW SWITCH COVER (x2).
6. ASSEMBLE FLOW SWITCH ONTO WATER I/O MANIFOLD.
7. FIT COMPLETED FLOW SWITCH/WATER I/O MANIFOLD ASSEMBLY ONTO MAGNET.

PROPRIETARY
 THIS DRAWING CONTAINS CONFIDENTIAL INFORMATION
 REPRODUCED OR DISCLOSED TO OTHERS OR USED IN ANY
 OTHER MANNER, IN WHOLE OR IN PART EXCEPT AS AUTHORIZED
 IN WRITING BY 3MWW INC.

14. WIRING DRAWINGS

14.1 Drawing 11901020 Motorized Rotating Drive Electrical Assembly

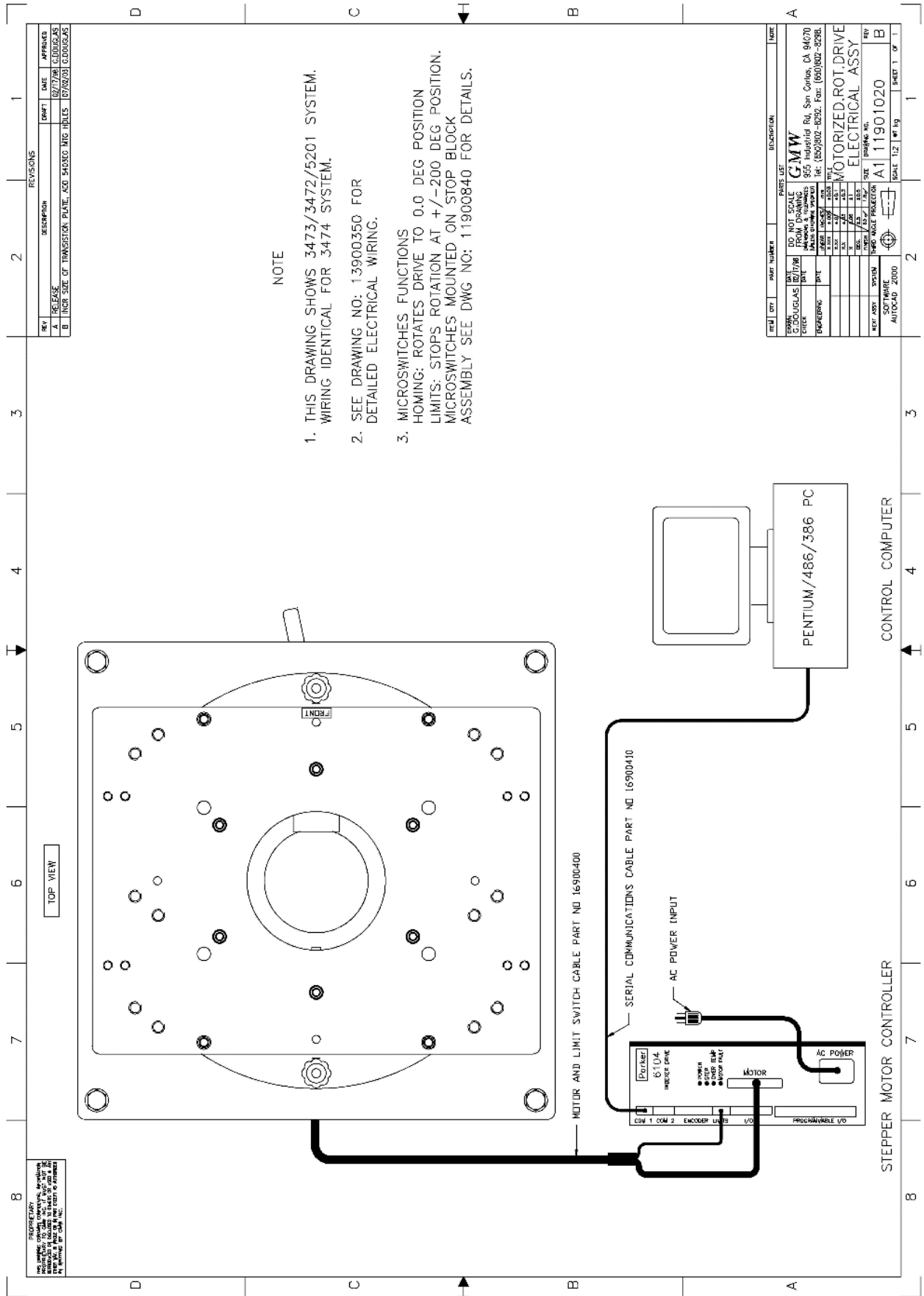

14.2 Drawing 13900350 Motorized Rotating Drive Electrical Wiring

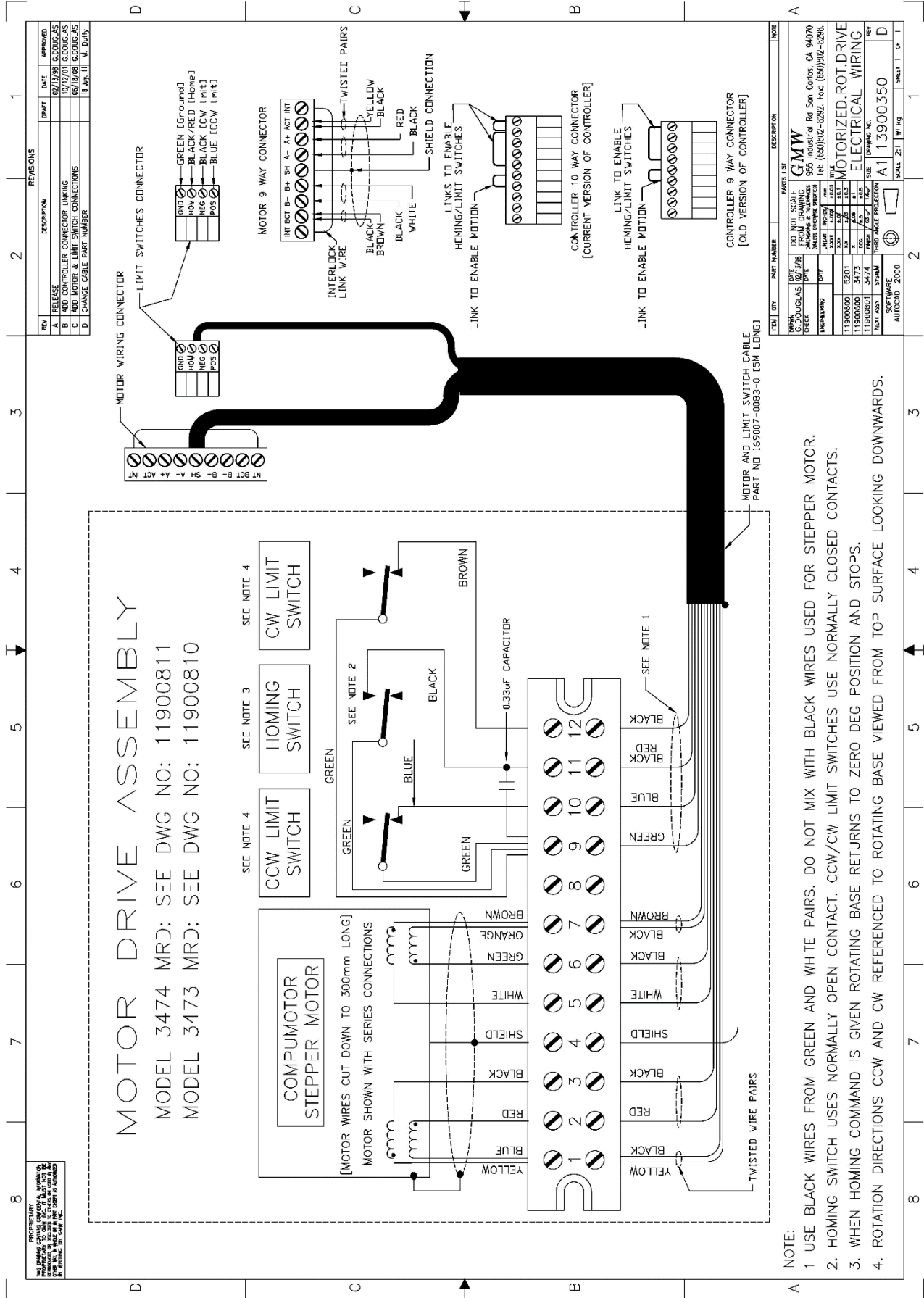

14.3 Drawing 1C907-0060-0 Electrical Assembly 3474/SGA100-150/5971

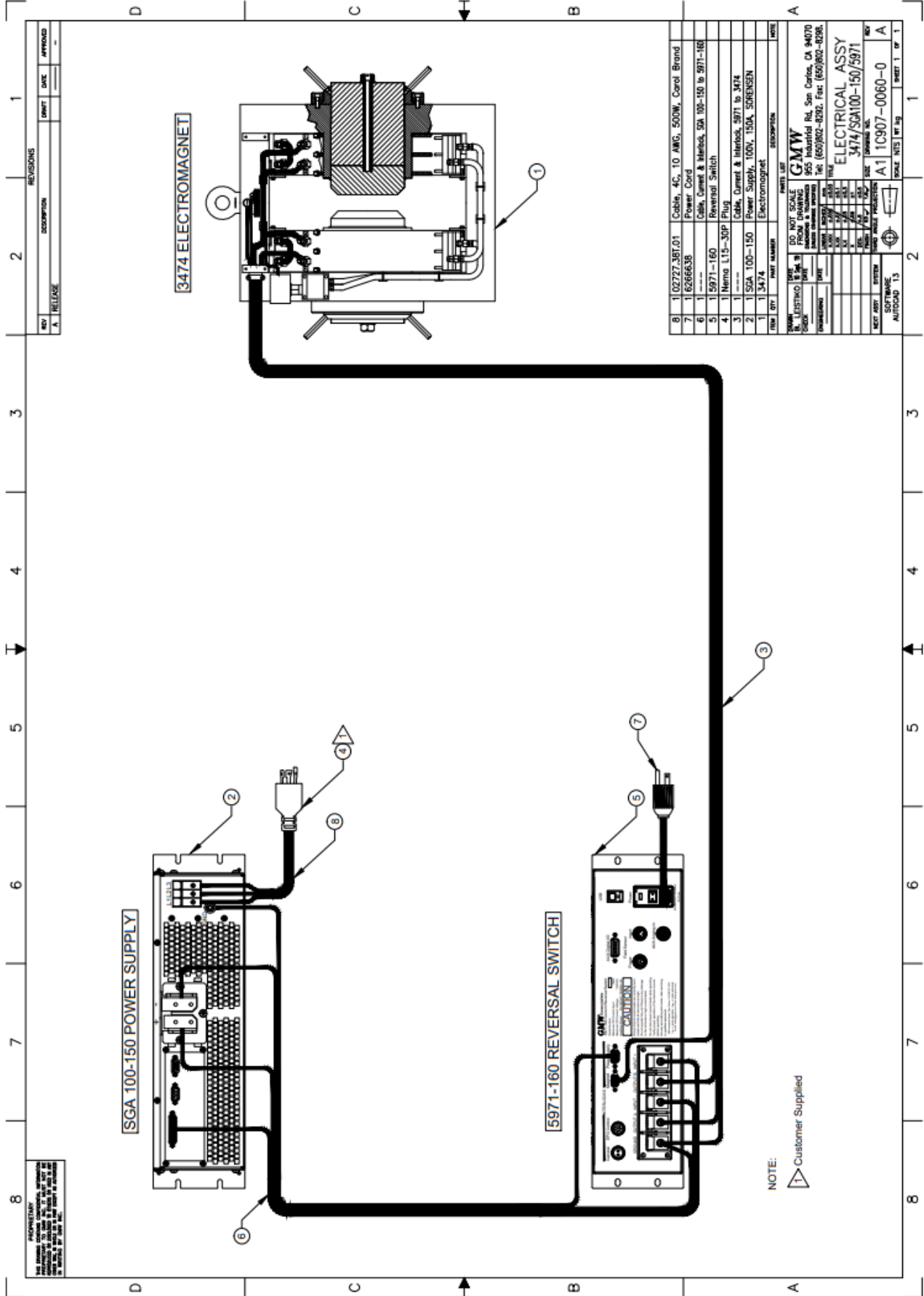

14.4 Drawing 1D907-0060-0 Electrical Wiring 3474/SGA100-150/5971

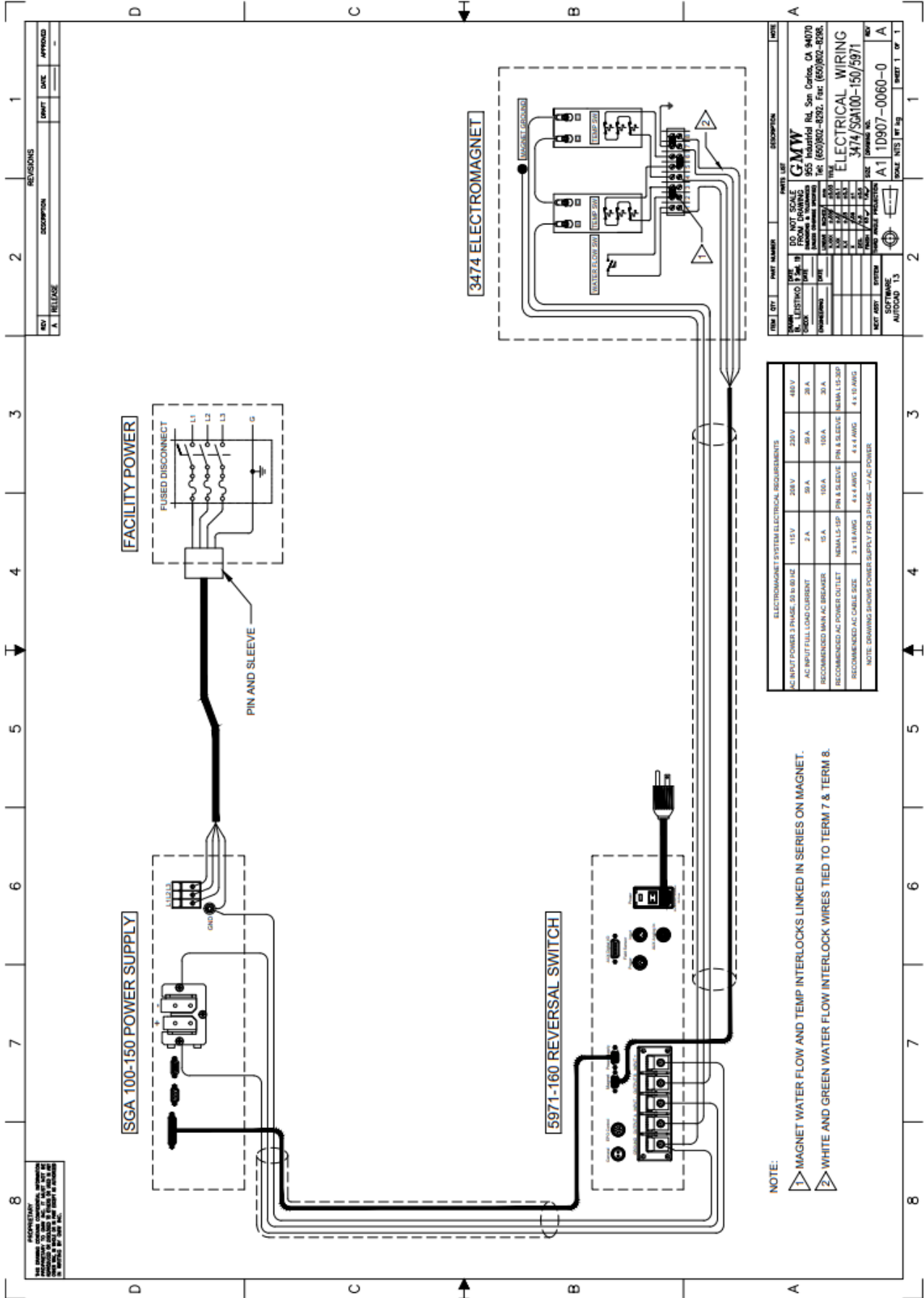

REV	DESCRIPTION	DATE	APPROVED
A	RELEASE		

REV	DESCRIPTION	DATE	APPROVED
A	RELEASE		

ELECTROMAGNET SYSTEM ELECTRICAL REQUIREMENTS			
AC INPUT POWER 3 PHASE, 50 HZ	115 V	230 V	480 V
AC INPUT FULL LOAD CURRENT	2 A	50 A	38 A
RECOMMENDED MAIN AC BREAKER	50 A	100 A	30 A
RECOMMENDED AC POWER OUTLET	NEUALS-1P	PN & SLEEVE	NEUAL 1.15-3P
RECOMMENDED AC CABLE SIZE	3 x 18 AWG	4 x 4 AWG	4 x 10 AWG

NOTE: DRAWING SHOWS POWER SUPPLY FOR 3 PHASE - 3P AC POWER

- NOTE:
- 1 MAGNET WATER FLOW AND TEMP INTERLOCKS LINKED IN SERIES ON MAGNET.
 - 2 WHITE AND GREEN WATER FLOW INTERLOCK WIRES TIED TO TERM 7 & TERM 8.

14.5 Drawing 1C907-0061-0 Electrical Assembly 3474/SGA100-200/5971

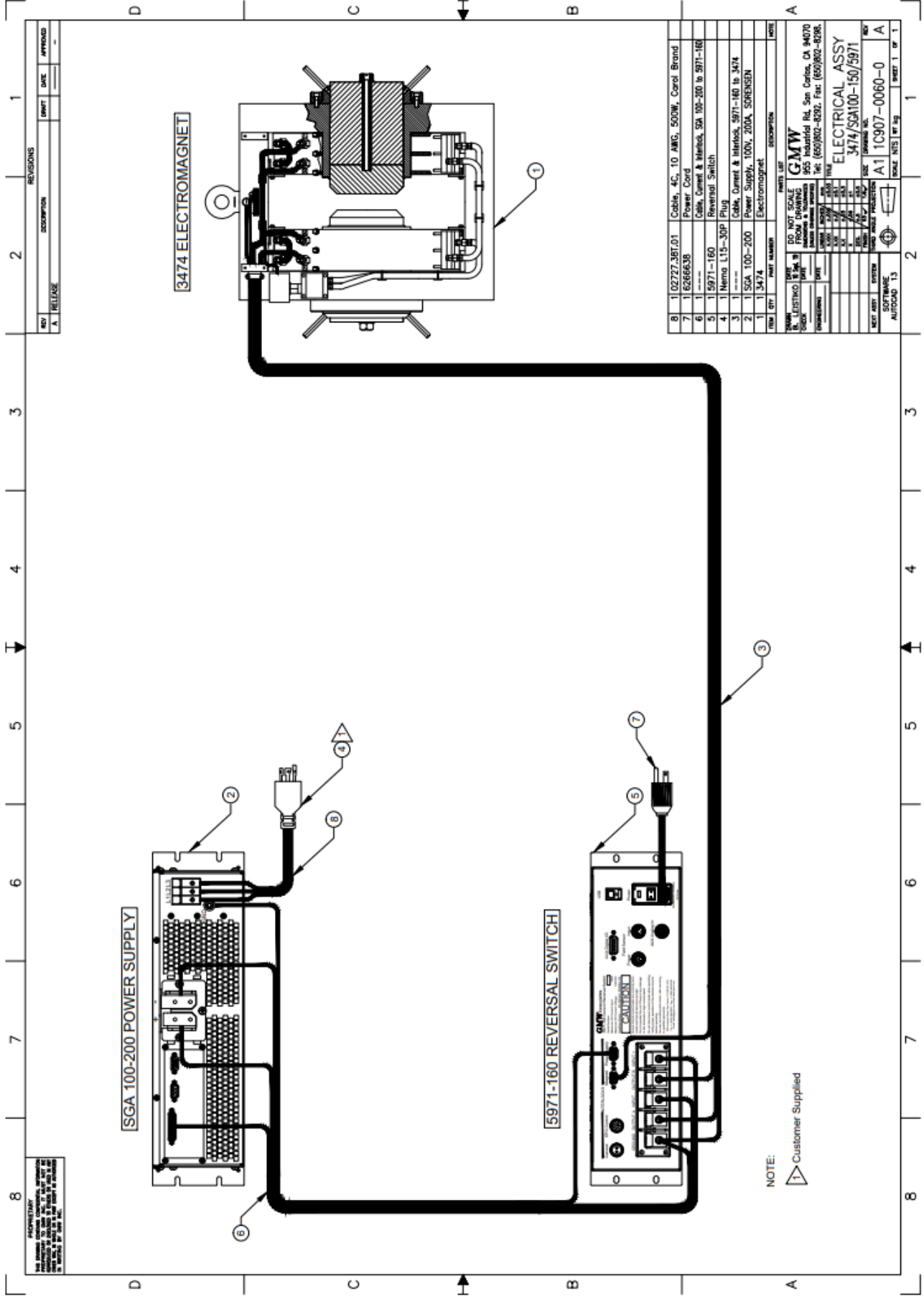

14.6 Drawing 1D907-0061-0 Electrical Wiring 3474/SGA100-200/5971

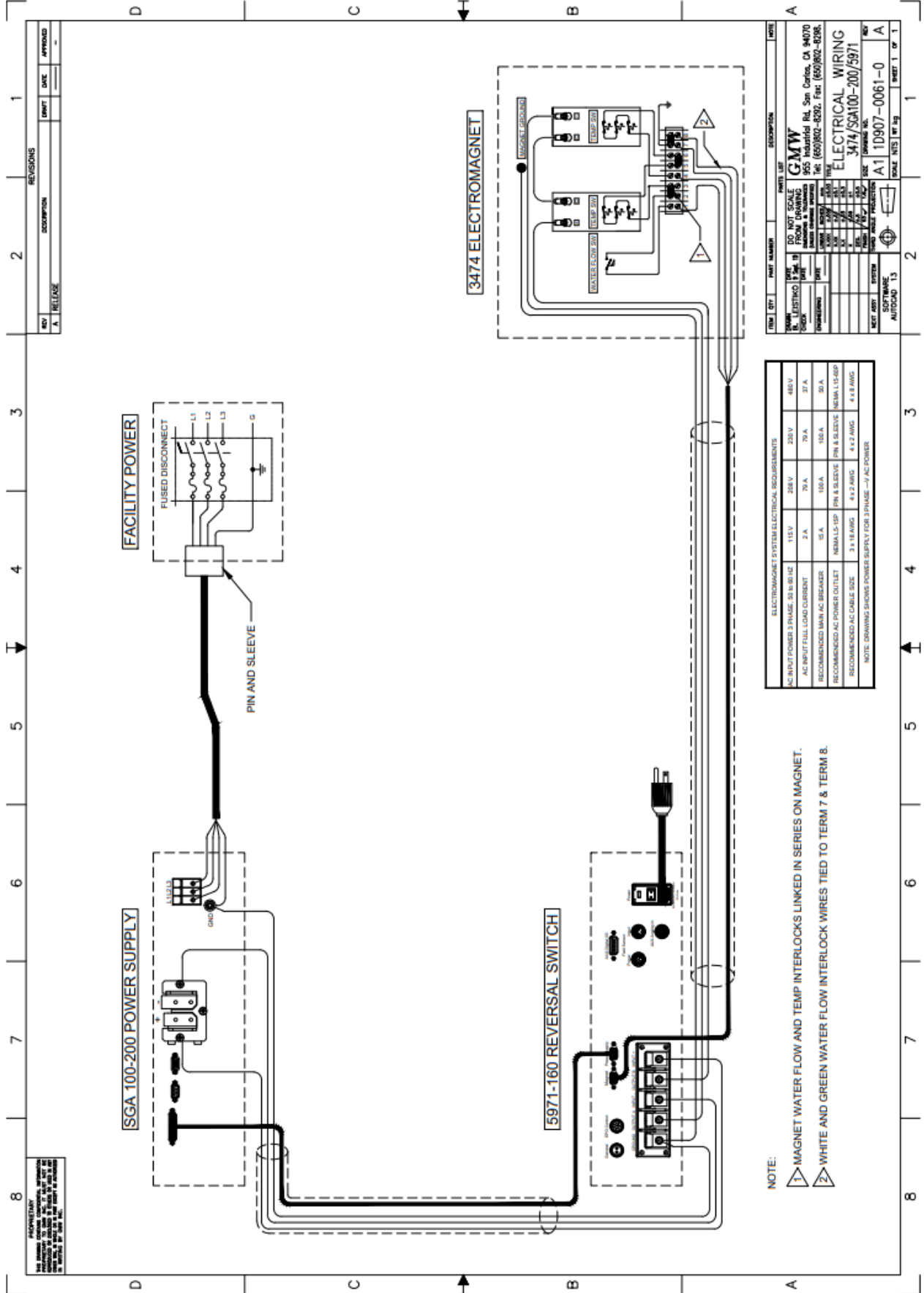

15. WARRANTY and SERVICE

GMW Associates warrants that Laboratory Electromagnets and Laboratory Electromagnet Systems supplied by GMW Associates will be free of defects in materials or workmanship for a period of 12 months from the date of installation or 15 months from the date of shipment whichever is the shorter.

Within this period GMW Associates will repair or replace defective parts free of charge either at the end user's site or at GMW Associates location at GMW's choice.

GMW Associates will reimburse or pay the lowest two way freight charges on items returned to GMW Associates or our authorized agent provided prior authorization for shipment has been given by GMW Associates.

This warranty shall not apply to any equipment which our inspection shows to have become defective due to mishandling, misuse, improper maintenance or any other damage not generally acceptable for equipment of a similar type.

GMW Associates reserves the right to make changes in product or system design without incurring any obligation to modify previously delivered equipment.

The foregoing is the full extent of the GMW Associates warranty. No other warranty is expressed or implied. In no event shall GMW Associates be liable for damage arising from late delivery or misuse of the equipment. GMW Associates makes no warranty of the fitness of the equipment for the intended end-use other than the equipment meets the written specifications presented to the purchaser by GMW Associates.

If any defect or fault in the equipment is discovered the end-user should notify GMW Associates of the problem including details of Model numbers and serial numbers. GMW Associates will either make arrangements for service by the end-user or GMW Associates, or give authorization for return shipment to GMW Associates.

All return shipments must be made according to GMW Associates instructions with adequate packaging and documentation identifying the shipment including the GMW Associates Return Material Authorization (RMA) number. GMW Associates will not accept responsibility for equipment damaged in return shipment and thus all shipments should be properly packed and adequately insured by the customer.

To request warranty service, please contact the GMW representative nearest you.

GMW Associates

Web: www.gmw.com/help/

Email: engineering@gmw.com

India: Transact.

Web: www.transact.co.in

Email: sales@transact.co.in

Japan: TOYO Corporation.

Web: www.toyo.co.jp/English/

Email: magne@toyo.co.jp

16. TECHNICAL REFERENCES

16.1 Thermo Scientific Water Chillers

GMW encourages a preventative maintenance regimen of all magnet system components, and that would include any recirculating water chillers. Please refer to the water chiller's manual for complete preventative maintenance instructions. For convenience, standard consumable items are listed below.

16.2 Water Filter Bag Kit

The filter bags should be replaced as required, but not less than every 6 months. Part Number: 598000000003

Description: Filter Kit, 100 micron, for Water Chillers

16.3 Thermo Scientific Contact Information

Website: ThermoFisher.com

Email: orderprocessing.led.asheville@thermofisher.com Tel: 866-984-3766

Please note that the above contact information is for ordering replacement supplies and not for general technical assistance.

16.4 Thermo Scientific Water Treatment Kit

To prevent damage to the magnet's water cooling circuits, the cooling water should be changed and treated on a regular schedule. Thermo Scientific has provided a water treatment kit that consists of a corrosion inhibitor and biocide. These kits are available from either GMW Associates or Thermo Scientific. Note that they have a fairly short shelf life. It is not recommended to generally stock this item.

Part Number: 610000000005

Description: Water Treatment Kit, Corrosion Inhibitor and Biocide, for recirculating Water Chillers



Thermo Scientific Cooling Water System: Cleaning/Flushing Procedures *Analytical Procedure*

The Thermo Scientific Chemical Kit (part #: 610000000005) consists of a corrosion/scale inhibitor (Product #: 460-Thermo100) and a biocide (Product #: 7330).

The Thermo Scientific Chemical Kit is designed to treat cooling water systems up to 10-gallons in volume.

Larger systems will require additional kits at 10-gallon intervals to maintain the chemical treatment program (for example, a 20-gallon system would require two kits).

DETERMINING THE CORRECT APPLICATION

Because the Thermo Scientific Chemical Kit can be used in different applications, determining which application you will need is critical to the success of the procedure. The guidelines for choosing the proper procedure for your needs are as follows:

If you are using the Thermo Scientific Chemical Kit in a new system that needs to be treated prior to normal operation, follow the procedure listed in the *End User Startup of a New System* section.

If you are using the Thermo Scientific Chemical Kit to conduct a routine maintenance flushing of an existing cooling water system, follow the procedure listed in the *Semiannual Water Change* section.

If you are using the Thermo Scientific Chemical Kit at the startup of an existing cooling water system that has had no previous treatment or a different chemical treatment, follow the procedure listed in the *Flushing and Startup for an Existing System* section.

If you are an original equipment manufacturer using the Thermo Scientific Chemical Kit in a new system that has not yet been shipped or stored, follow the procedure listed in the *Pre-ship Test/Passivate* section.



END USER STARTUP OF NEW SYSTEM

Purpose

The cooling water systems in new units need to be treated before initiating normal operation and treatment. The following procedure will delineate the procedure for starting up the new cooling water system and improve system performance and reliability.

Procedure

- 3 Confirm the unit is ready for operation.**
- 4 Fill the cooling water system with deionized (DI), distilled or Reverse Osmosis (RO) water and circulate for several minutes. Repair any leaks before proceeding.**
- 5 Add the contents of the bottle labeled 460-Thermo100. Circulate for 10-15 minutes.**
- 6 Add the contents of the bottle labeled NALCO 7330.**
- 7 Attach the Fluid Replacement Reminder sticker to a prominent location on the unit. Sign and date the sticker noting when the system was treated and a scheduled date for the next treatment.**
- 8 The system is now ready for use.**

16.5 Selco Thermostat Specifications

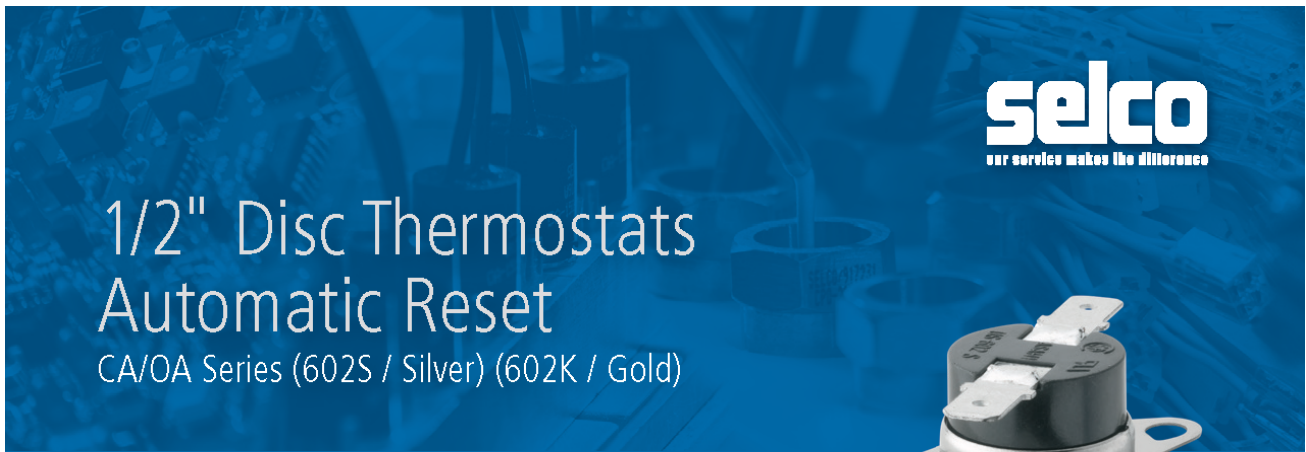

Bi-Metal Temperature Controls

Selco's comprehensive line of highly reliable switches utilize a temperature sensitive bi-metal disc, electrically isolated from the switch. Contacts will close (CA Series) or open (OA Series) on temperature rise when the surface or ambient temperature increases to the snap point of the calibrated bi-metal disc. The entire switch is enclosed in a phenolic dust-free housing. The bi-metal disc is retained by a metal heat conducting sensing cap and are all single pole, single throw non-adjustable switches. To provide flexibility for customer specific applications, we offer a variety of terminal and mounting configurations.

Selco switches are produced in an ISO 9001 certified factory to insure safe and reliable operation. All models are 100% factory inspected to ensure proper temperature, continuity and function.

Custom Manufacturing options are available including: brackets, pipe and tube mounts, lead termination, over-molding and epoxy sealing. For details regarding custom 1/2" disc assemblies see Custom Part Configurator XXXXX.

Everyday Applications

Warming Equipment	Fan Heaters	Refrigerators	Dryers
Washing Machines	Electric Heaters	Furnaces	Boilers
Microwave Ovens	Water Heaters	Fireplaces	And More...
Coffee Makers	Seat Heaters	Toasters	

TEMP RANGE	TEMP TOLERANCE		DIFFERENTIAL
	SET POINT	RESET POINT	
32°-122°F (0°-50°C)	±7.2°F (4°C)	±9°F (5°C)	CUSTOMER SPECIFIED
123°-212°F (51°-100°C)	±7.2°F (4°C)	±10.8°F (6°C)	CUSTOMER SPECIFIED
213°-302°F (101°-150°C)	±9°F (5°C)	±12.6°F (7°C)	CUSTOMER SPECIFIED

*Temperature rate of change at 1°F (.5°C) per minute

*Tighter tolerance available upon request

Technical Specifications

Silver Contacts (602S)

Environmental Temperature
-40°-350°F (-20°-150°C)

Electrical Ratings
125VAC, 15A, Resistive, 100,000 Cycles
250VAC, 8A, Resistive, 100,000 Cycles
120VAC, 5.8FLA, 34.8LRA, 6,000 Cycles
240VAC, 2.9FLA, 17.4LRA, 6,000 Cycles

Insulation Resistance
≥100mΩ (with a 500VDC Megger)

Circuit Resistance
≤50mΩ (initial value)

Dielectric Strength
1,500VAC/1-min or 1,800VAC/1-sec

Certifications
UL (E145478, XAPX2), CSA (1061290), RoHS

Gold Contacts (602K)

Environmental Temperature
-40°-350°F (-20°-150°C)

Electrical Ratings
30VDC, 1A, Resistive, 100,000 Cycles
120VAC, 125VA (Pilot Duty), 1A

Insulation Resistance
≥100mΩ (with a 500VDC Megger)

Circuit Resistance
≤10mΩ (initial value)

Dielectric Strength
1,200VAC/1-min

Certifications
UL (E145478, XAPX2), c-UL (E145478, XAPX8), RoHS

RoHS
Compliant

For more information on Selco Products please visit us at: www.selcoproducts.com

16.6 Model 3474 System Installation; North America

Minimum Facility Requirements for Systems with Field Reversal, High Precision Systems and High Power Systems installed in North America

Floor Space:

Magnet Floor Area: 830 x 830mm (33 x 33")

Floor Capacity: 1800kg (3,980lb)

Power Supply & Rack Floor Area: 700 x 900mm (28 x 36")

Floor Capacity: 100kg (220lb)

An area for access to the Magnet and Power Supply must be provided. The total area for the system and comfortable operation is about 3 x 3m (10 x 10ft). The area should be clean and free from obstructions.

Electrical Service:

	High Precision System	System with Field Reversal
MPS Power:		
Power Supply:	Danfysik 853-160A/80V	SGA100x150C
Voltage:	208Vac, Three Phase, 50 – 60Hz	208Vac, Three Phase, 50 – 60Hz
Current:	56 Amps per phase	74 Amps per phase
Circuit Breaker:	60 Amps minimum	80 Amps minimum
Power Cable:	4 Conductor, 4AWG Min.	4 Conductor, 3AWG Min.
Mains Outlet:	Nema 15-60R or equivalent	Hard-wired in to electrical panel
Mating Plug:	Nema 15-60P or equivalent	(no suitable plugs are available)
Auxiliary Power for Rack:		
Voltage:	115Vac, Single Phase	
Current:	15A	

Note: Due to liability and insurance reasons, the mains power installation and connections must be completed by the facility electrician.

Water Cooling:

Water Temperature: 15°C to 20°C, non-condensing. Specifications given at 18°C

Flow Rate: 15 liters / minute (4 US gpm)

Pressure: 2 bar (30 PSID)

Water Hose: 12.5mm I.D. (½"), rubber, 2 x 5m long minimum

Plumbing Fittings: To connect 12.5mm hose to water source and drain. (It is recommended to have a 50 micron water filter to trap debris on the facility water source and shutoff valves on the water source and drain.)

System Computer (if required and not provided by GMW):

Processor: Intel Pentium III, 500MHz PC or better

Memory: 128MB RAM

Free Drive Space: 500MB

Interface: IEEE-488 (GIPB), National Instruments GPIB-PCII/IIA, P/N: 777158-01

Monitor Resolution: 1024 x 768 or better

Operating System: Windows ME / 2000 / XP pro / NT4

Equipment Rack (if required and not provided by GMW):

Depth: 760mm (30")

Free Space: 14U high (~24.5")

Lifting Equipment for Installation:

Forktruck or other lifting device with minimum safe lifting capacity of 2000kg

Nylon Slings with minimum safe lifting capacity of 2000kg

General:

The Purchaser must provide all equipment and labor for delivering the equipment from the delivery dock to the installation site. You should have a User Manual for the Model 3474 250mm Electromagnet and for the magnet power supply. Please provide these to the person who will be responsible for the System installation. If you do not have the User Manual or need to discuss details of the installation please call GMW. If a GMW Engineer is to supervise the installation any delays caused by inadequate preparation may result in additional charges for Engineering Time.

If you are providing your own equipment rack, it must be a minimum of 760mm (30") deep.

Note: The weight of an assembled 3474 magnet system is just over 4300 lbs. It is not possible to rig and move this magnet by hand, so use of proper lifting equipment is required (either an appropriately rated lift truck or a traveling crane). It is the responsibility of the facility to provide the means to move and lift the magnet for assembly on to its base and move it to its final installed position. If the means to do this is not available in-house, the customer may be required to hire an outside rigging company to lift and move the magnet. Scheduling of the riggers is the responsibility of the customer. Should the installation time be extended due to problems with the rigger scheduling, GMW reserves the right to bill for additional time beyond the original contracted amount.

Important: Due to liability and insurance reasons, the mains power installation and connections must be completed by the facility electrician. The GMW engineer will not complete the mains power connection. Please ensure that the facility electrician is available to do this work.

16.7 Model 3474 System Installation; Check List

Site:

___ Floor space and work space cleared and ready for equipment installation.

___ Appropriate electrical services installed

Materials Required:

___ Power Plugs

___ Power Cable

___ Facility Electrician ready to make mains connections to power supply at the time of system install

___ Cooling water supply installed with shut-off valves

Materials Required:

___ 12.5mm I.D. (1/2") water hose, 5m for source and 5m for drain

___ Water hose fittings appropriate for installed plumbing

___ Water hose clamps

Misc. Items (to be provided by facility):

Tools:

___ Power Drill with 5/16" socket (to open magnet crates)

___ 24mm combination wrench (open and box end)

___ 24mm socket wrench (for attaching the angle brackets to the magnet)

___ 3/4" socket wrench (for removal of magnet from shipping crate)

___ Nylon lifting slings, chains, cables and other rigging equipment suitable for lifting magnet.

Other Items:

___ 4" x 4" x 3' wood blocks. (about 4 – 6 pieces)

___ 3' x 3' 3/4" plywood

All required materials on this list are to be provided by the facility.