

Datasheet: SENIS 3MH1 Teslameter

3-axis portable SENIS Handheld Teslameter

DESCRIPTION:

SENIS Handheld Teslameter is an easy-to-use portable teslameter which allows users to measure all 3 components of the magnetic field.

It simultaneously measures the magnetic field with a direct view of the magnetic field strength on the integrated touchscreen.

With user-friendly software unit of the measured magnetic field, gain, and measurement averaging time window can be changed.

Build-in software allows user to download recorded data in CSV file via web interface.

It is powered from the internal battery, and it does not require to be powered by an external power supply.

Due to unique features of the applied fully integrated 3-axis Hall probe, all three components of the magnetic field (B_x , B_y , B_z) are measured simultaneously at virtually same point. It allows users to perform a fast, high-resolution measurement of magnetic flux density of the magnetic fields. The measured values are presented on the device touch-display. The magnetic field sensitive area of the applied Hall probes is within a $100\ \mu\text{m} \times 100\ \mu\text{m}$ square, which allows measurements of homogeneous and highly inhomogeneous magnetic fields.



Figure 1: SENIS 3MH1 Handheld Teslameter

KEY FEATURES:

- Fast, accurate view of magnetic field strength
- Portable device without the need for an external power supply
- Build-in touch screen to operate the teslameter
- Measures all three 3 field components of a magnetic field (Bx, By, Bz)
- Very high magnetic resolution
- Small sensitive volume of $100\mu\text{m} \times 100\mu\text{m} \times 10\mu\text{m}$

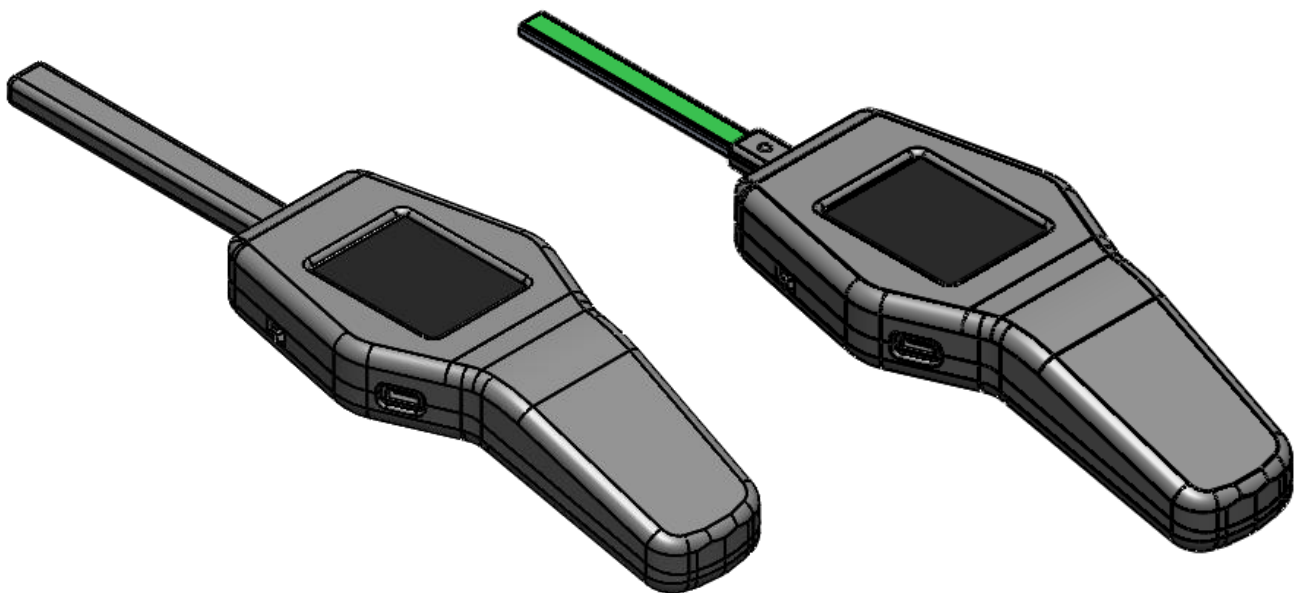

Figure 2: SENIS 3MH1 Handheld Teslameter with and without the nose cover

TYPICAL APPLICATIONS:

- Quality control and monitoring of permanent magnets and systems
- Measurements in hard-to-reach places
- Measurement of the environmental magnetic fields
- Development of magnet systems & process control
- Application in laboratories and in production lines

SPECIFICATIONS:

Magnetic measuring properties	
Measurement ranges	$\pm 60\text{mT}$ / $\pm 500\text{mT}$ / $\pm 4\text{T}$ (extrapolated from measured data up to $\pm 2\text{T}$)
Measurement Volume	100 μm x 100 μm x 10 μm
Accuracy of measurement	2% of full scale
Digital resolution	11bit
Resolution	at 60mT range - 30 μT
	at 500mT range - 250 μT
	at 4T range - 2mT
Frequency Range	0-2kHz
Calibrated temperature range	20° - 30°C
Software and Communication	
Power Supply	External, 5V, 1A, rechargeable NiMH battery
Touch screen	Capacitive LCD with backlight for good visibility
Interface	USB 3.0
File format for data exchange	.csv
Operation Options	
Setting Zero	
Start/Stop streaming acquisition	
Hold Function	
True RMS	
Battery Status Display	
Displayed units: Gauss / mT / T	
Mechanical	
Housing	Rugged, lightweight
Total weight	160g
Operation temperature range	10°C - 50°C

DIMENSIONS:

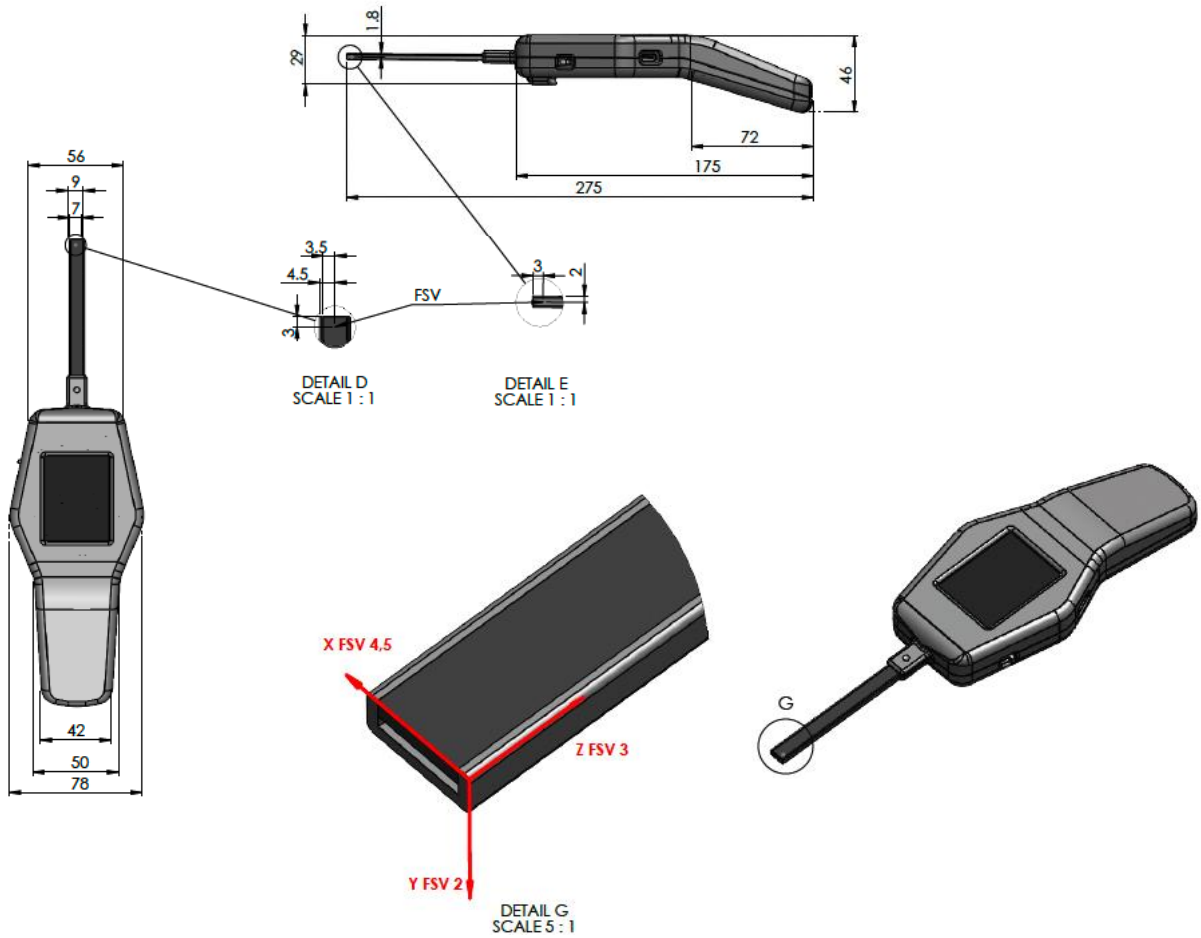

Figure 4: Structure and dimensions of the 3MH1 Handheld Teslameter and position of the FSV.

Distributed by: GMW Associates. 955 Industrial Road, San Carlos, CA, 94070, USA
 PHONE: +1-650-802-8292 FAX: +1-650-802-8298 EMAIL: sales@gmw.com WEB: www.gmw.com